

Fundamental Principles of Mechanical Engineering

Technical Handbook

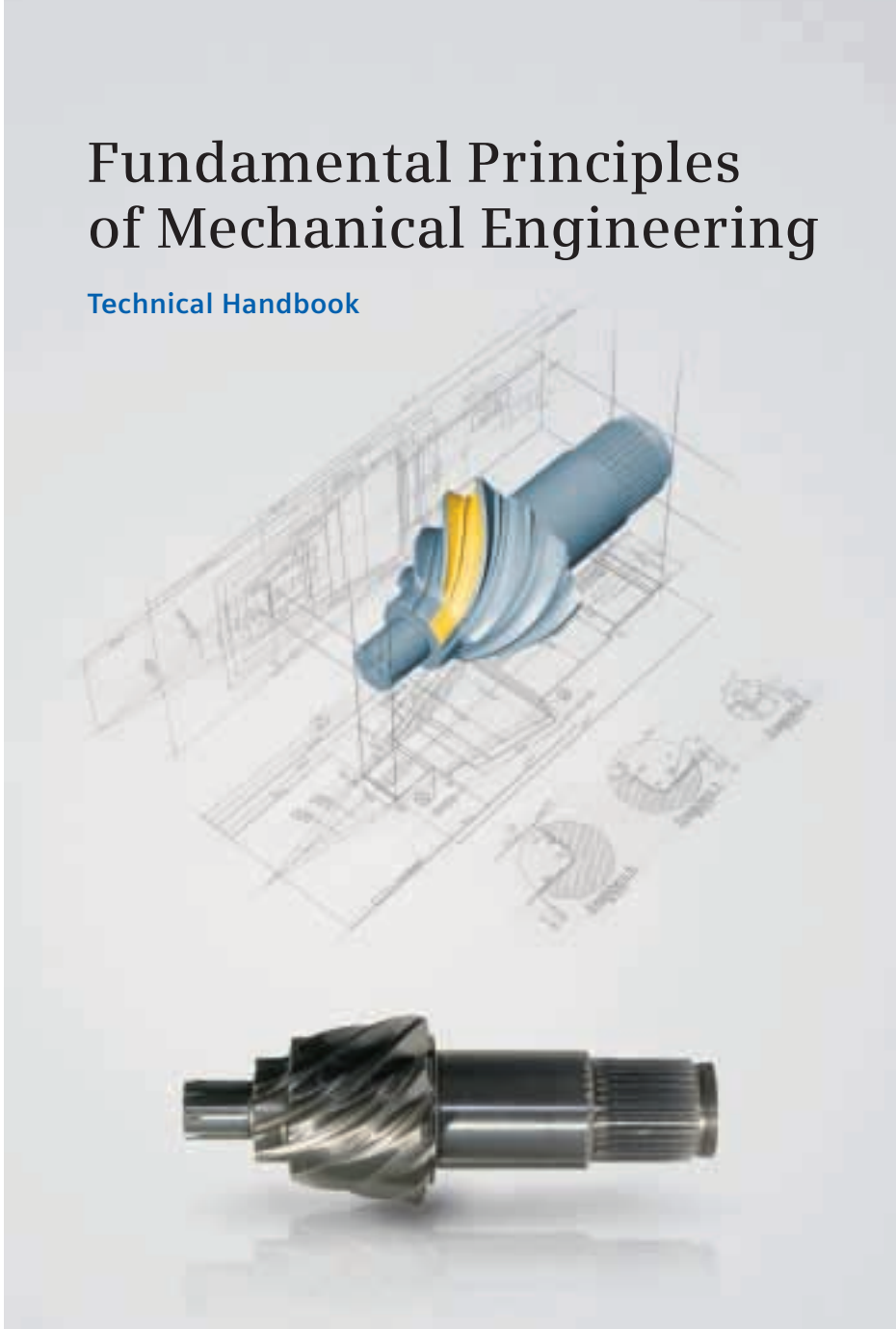

FLENDER Drives

Answers for industry.

SIEMENS

FLENDER Drives

Fundamental Principles of Mechanical Engineering

Technical Handbook

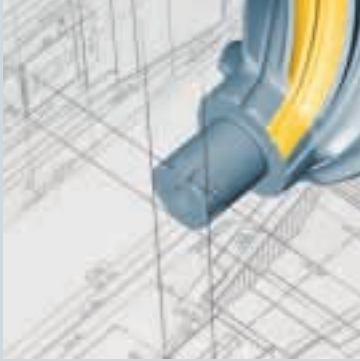

Technical Drawings	1
Standardization	2
Physics	3
Mathematics / Geometry	4
Mechanics / Strength of Materials	5
Hydraulics	6
Electrical Engineering	7
Materials	8
Lubricating Oils	9
Cylindrical Gear Units	10
Shaft Couplings	11
Vibrations	12
Bibliography	13



Answers for Industry.

Siemens Industry answers the challenges in the manufacturing and the process industry as well as in the building automation business. Our drive and automation solutions based on Totally Integrated Automation (TIA) and Totally Integrated Power (TIP) are employed in all kinds of industry. In the manufacturing and the process industry. In industrial as well as in functional buildings.

Siemens offers automation, drive, and low-voltage switching technology as well as industrial software from standard products up to entire industry solutions. The industry software enables our industry customers to optimize the entire value chain – from product design and development through manufacture and sales up to after-sales service. Our electrical and mechanical components offer integrated technologies for the entire drive

train – from couplings to gear units, from motors to control and drive solutions for all engineering industries. Our technology platform TIP offers robust solutions for power distribution.

Check out the opportunities our automation and drive solutions provide. And discover how you can sustainably enhance your competitive edge with us.

Contents

Section 1	Page
Technical Drawings	
Surface Texture	5 + 6
Geometrical Tolerancing	7 – 21
Sheet Sizes, Title Block, Non-standard Formats	22
Type Sizes, Lines, Lettering Example	23
Section 2	
Standardization	
ISO Metric Screw Threads (Coarse Pitch Threads)	25
ISO Metric Screw Threads (Coarse and Fine Pitch Threads)	26
Cylindrical Shaft Ends	27
ISO Tolerance Zones, Allowances, Fit Tolerances	28 + 29
Parallel Keys and Taper Keys, Centre Holes	30
Section 3	
Physics	
Internationally Determined Prefixes	32
Basic SI Units	32
Derived SI Units	33
Legal Units Outside the SI	33
Physical Quantities and Units of Lengths and Their Powers	34
Physical Quantities and Units of Time	35
Physical Quantities and Units of Mechanics	35 – 37
Physical Quantities and Units of Thermodynamics and Heat Transfer	37 + 38
Physical Quantities and Units of Electrical Engineering	38
Physical Quantities and Units of Lighting Engineering	39
Different Measuring Units of Temperature	39
Measures of Length and Square Measures	40
Cubic Measures and Weights	41
Energy, Work, Quantity of Heat	41
Power, Energy Flow, Heat Flow	42
Pressure and Tension	42
Velocity	42
Equations for Linear Motion and Rotary Motion	43
Section 4	
Mathematics / Geometry	
Calculation of Areas	45
Calculation of Volumes	46
Section 5	
Mechanics / Strength of Materials	
Axial Section Moduli and Axial Second Moments of Area (Moments of Inertia) of Different Profiles	48
Deflections in Beams	49
Values for Circular Sections	50
Stresses on Structural Members and Fatigue Strength of Structures	51

Contents

Section 6	Page
Hydraulics	
Hydrostatics	53
Hydrodynamics	54
Section 7	
Electrical Engineering	
Basic Formulae	56
Speed, Power Rating and Efficiency of Electric Motors	57
Types of Construction and Mounting Arrangements of Rotating Electrical Machinery	58
Types of Protection for Electrical Equipment (Protection Against Contact and Foreign Bodies)	59
Types of Protection for Electrical Equipment (Protection Against Water)	60
Section 8	
Materials	
Conversion of Fatigue Strength Values of Miscellaneous Materials	62
Mechanical Properties of Quenched and Tempered Steels	63
Fatigue Strength Diagrams of Quenched and Tempered Steels	64
General-Purpose Structural Steels	65
Fatigue Strength Diagrams of General-Purpose Structural Steels	66
Case Hardening Steels	67
Fatigue Strength Diagrams of Case Hardening Steels	68
Cold Rolled Steel Strips	69
Cast Steels for General Engineering Purposes	69
Round Steel Wire for Springs	70
Lamellar Graphite Cast Iron	71
Nodular Graphite Cast Iron	71
Copper-Tin- and Copper-Zinc-Tin Casting Alloys	72
Copper-Aluminium Casting Alloys	72
Aluminium Casting Alloys	73
Lead and Tin Casting Alloys for Babbit Sleeve Bearings	74
Conversion of Hardness Values	75
Values of Solids and Liquids	76
Coefficient of Linear Expansion	77
Iron-Carbon Diagram	77
Pitting and Tooth Root Fatigue Strength Values of Steels	77
Heat Treatment During Case Hardening of Case Hardening Steels	78
Section 9	
Lubricating Oils	
Viscosity-Temperature-Diagram for Mineral Oils	80
Viscosity-Temperature-Diagram for Synthetic Oils of Poly- α -Olefine Base	81
Viscosity-Temperature-Diagram for Synthetic Oils of Polyglycole Base	82
Kinematic Viscosity and Dynamic Viscosity	83
Viscosity Table for Mineral Oils	84

Contents

Section 10	Page
Cylindrical Gear Units	
Symbols and Units	86 + 87
General Introduction	88
Geometry of Involute Gears	88 – 89
Load Carrying Capacity of Involute Gears	99 – 107
Gear Unit Types	107 – 110
Noise Emitted by Gear Units	111 – 114
Section 11	
Shaft Couplings	
General Fundamental Principles	116
Torsionally Rigid Couplings, Flexible Pin Couplings	117
Flexible Claw Couplings	
Highly Flexible Ring Couplings, Highly Flexible Rubber Tyre Couplings	118
Highly Flexible Rubber Disk Couplings, Flexible Pin and Bush Couplings	
All-steel Couplings, Torque Limiters	119
High-speed Couplings, Composite Couplings	
Miniature Couplings, Gear Couplings	120
Universal Gear Couplings, Multiple Disk Clutches	
Fluid Couplings, Overrunning Clutches, Torque Limiters	121
Couplings for Pump Drives	122
Coupling Systems for Railway Vehicles	123
Coupling Systems for Wind Power Stations	124
Section 12	
Vibrations	
Symbols and Units	126
General Fundamental Principles	127 – 129
Solution Proposal for Simple Torsional Vibrators	129 + 130
Solution of the Differential Equation of Motion	130 + 131
Formulae for the Calculation of Vibrations	131
Terms, Symbols and Units	132
Formulae for the Calculation of Vibrations	133 – 135
Evaluation of Vibrations	135 + 136
Section 13	
Bibliography of Sections 10, 11, and 12	138 + 139

Technical Drawings	Page
Surface Texture	
Method of Indicating Surface Texture on Drawings acc. to DIN EN ISO 1302	5
Surface Roughness Parameters	5 + 6
Geometrical Tolerancing	
General	7
Application; General Explanations	7
Tolerance Frame	7
Kinds of Tolerances; Symbols; Included Tolerances	8
Additional Symbols	8
Toleranced Features	9
Tolerance Zones	9
Datums and Datum Systems	9 – 11
Theoretically Exact Dimensions	11
Detailed Definitions of Tolerances	11 – 21
Sheet Sizes, Title Block, Non-standard Formats	
Sheet Sizes for Technical Drawings	22
Title Block for Technical Drawings	22
Non-standard Formats for Technical Drawings	22
Sizes of Type	23
Lines acc. to DIN ISO 128, Part 20 and Part 24	23
Lettering Example	23

1. Method of indicating surface texture on drawings acc. to DIN EN ISO 1302

1.1 Symbols for the surface texture	
Graphic symbols	Meaning
	Material removal by machining is required (without requirements).
	Material removal by machining is required (with additional indication).
	Material removal is prohibited (without requirements).
	Material removal is prohibited (with additional indication).
	Material removal; surface roughness value $Ra = 6.3 \mu\text{m}$.
	Material removal applies to the external contour of the view.
	Machining allowance specified by a numerical value in mm (e.g. 3 mm).
	Material removal (by machining), surface roughness value $Ra = 0.4 - 0.8 \mu\text{m}$. Requirement for the surface: "lead-free".

1.2 Definition of the surface parameter Ra

The centre line average height Ra of the assessed profile is defined in DIN EN ISO 4287 and the evaluation length for assessing the roughness in DIN EN ISO 4288.

1.3 Indications added to the graphic symbols

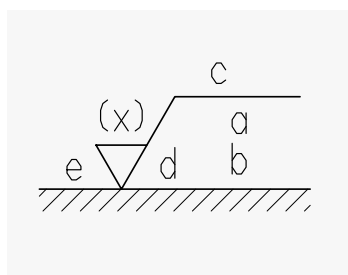

- a = Requirements on the surface appearance
- b = Two or more requirements on the surface appearance
- c = Production method, treatment, coating, or other requirements concerning the manufacturing method, etc.
- d = Surface grooves and their direction
- e = Machining allowance
- (x) = No longer applicable (formerly: indication of Ra)

2. Surface roughness parameters

2.1 Peak-to-valley height Rt

The peak-to-valley height Rt in μm acc. to DIN 4762 Part 1 is the distance of the base profile to the reference profile (see figure 1). The base profile is the reference profile displaced to such an extent perpendicular to the geometrical ideal profile within the roughness reference length, that contacts the point of the actual profile most distant from the reference profile (point T in figure 1).

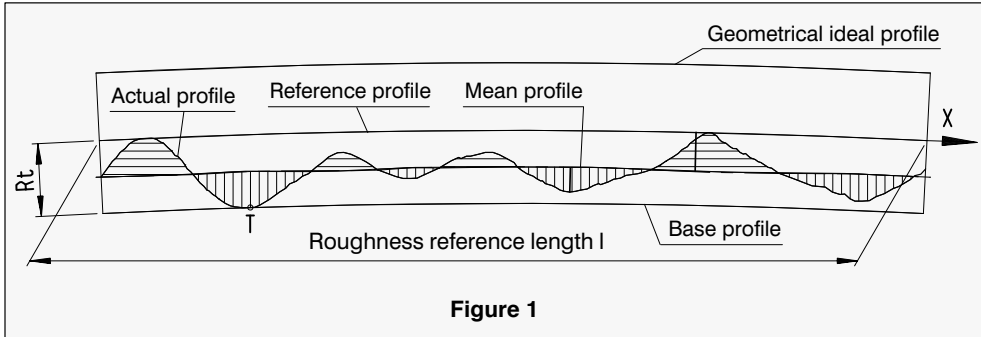

Figure 1

2.2 Mean peak-to-valley height Rz

The mean peak-to-valley height Rz in μm acc. to DIN 4768 is the arithmetic average of the single irregularities of five consecutive sam-

pling lengths (see figure 2).

Note: The definition given for Rz in DIN differs from its definition in ISO.

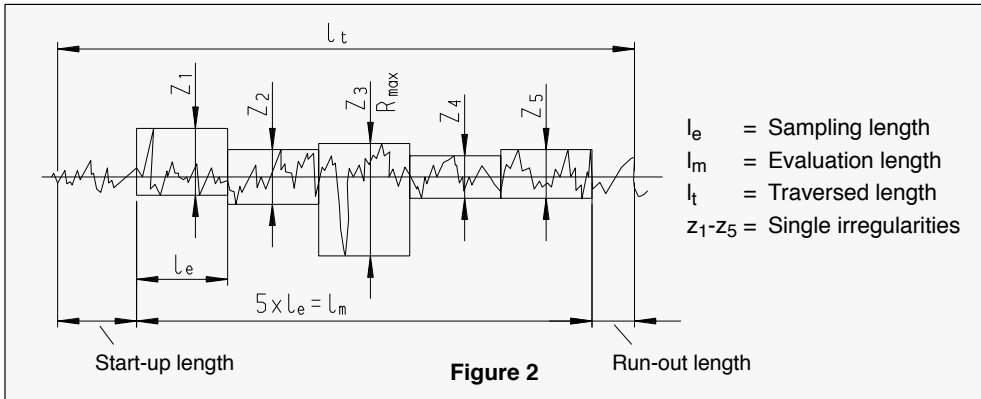

Figure 2

- l_e = Sampling length
- l_m = Evaluation length
- l_t = Traversed length
- Z_1 - Z_5 = Single irregularities

An exact conversion of the peak-to-valley height Rz into the centre line average height Ra and vice versa can neither be theoretically justified nor empirically proved. For surfaces which are generated by manufacturing methods of the group “metal cutting”, a diagram for the conversion from Ra into Rz and vice versa is shown in supplement 1 to DIN 4768, based on comparison measurements. The Ra values assigned to the Rz values are subject to scattering (see table).

2.3 Maximum roughness height $Rmax$

The maximum roughness height $Rmax$ in μm acc. to DIN 4768 is the largest of the single irregularities Z_1 occurring over the evaluation length l_m (see figure 2). $Rmax$ is applied only in cases where the largest single irregularity (“runaway”) is to be recorded for reasons important for function.

2.4 Roughness grade numbers N

In Germany, it is not allowed to use roughness grade numbers (N grades), since they are given in inches.

3. Centre line average height Ra and roughness grade numbers in relation to the mean peak-to-valley height Rz													
Surface roughness value	μm	50	25	12.5	6.3	3.2	1.6	0.8	0.4	0.2	0.1	0.05	0.025
Ra	μin	2000	1000	500	250	125	63	32	16	8	4	2	1
Roughness grade no.		N 12	N 11	N 10	N 9	N 8	N 7	N 6	N 5	N 4	N 3	N 2	N 1
Surface roughness value	from	160	80	40	25	12.5	6.3	3.15	1.6	0.8	0.4	0.25	0.1
Rz in μm	to	250	160	100	63	31.5	20	12.5	6.3	4	2.5	1.6	0.8

4. General

4.1 The particulars given are in accordance with the international standard DIN ISO 1101, March 1985 edition.

This standard gives the principles of symbolization and indication on technical drawings of tolerances of form, orientation, location and runout, and establishes the appropriate geometrical definition. The term “geometrical tolerances” is used in this standard as generic term for these tolerances.

4.2 Relationship between tolerances of size, form and position

According to current standards there are two possibilities of making indications on technical drawings in accordance with:

- a) the principle of independence according to DIN ISO 8015 where tolerances of size, form and position must be adhered to independent of each other, i.e. there is no direct relation between them. In this case reference must be made on the drawing to DIN ISO 8015.
- b) the envelope requirements according to DIN 7167, according to which the tolerances of size and form are in direct relation with each other, i.e. that the size tolerances limit the form tolerances.

5. Application; general explanations

5.1 Geometrical tolerances shall be specified on drawings only if they are imperative for the functioning and/or economical manufacture of the respective workpiece. Otherwise, the general tolerances according to DIN ISO 2768 apply.

5.2 Indicating geometrical tolerances does not necessarily imply the use of any particular method of production, measurement or gauging.

5.3 A geometrical tolerance applied to a feature defines the tolerance zone within which the feature (surface, axis, or median plane) is to be contained. According to the characteristic to be tolerated and the manner in which it is dimensioned, the tolerance zone is one of the following:

- the area within a circle;
- the area between two concentric circles;
- the area between two equidistant lines or two parallel straight lines;
- the space within a cylinder;
- the space between two coaxial cylinders;
- the space between two parallel planes;
- the space within a parallelepiped or a sphere.

The tolerated feature may be of any form or orientation within this tolerance zone, unless a more restrictive indication is given.

5.4 Unless otherwise specified, the tolerance applies to the whole length or surface of the considered feature.

5.5 The datum feature is a real feature of a part, which is used to establish the location of a datum.

5.6 Geometrical tolerances which are assigned to features referred to a datum do not limit the form deviations of the datum feature itself. The form of a datum feature shall be sufficiently accurate for its purpose and it may therefore be necessary to specify tolerances of form for the datum features (see table on page 8).

5.7 Tolerance frame

The tolerance requirements are shown in a rectangular frame which is divided into two or more compartments. These compartments contain, from top to bottom, in the following order (see figures 3, 4 and 5):

- the symbol for the characteristic to be tolerated;
- the tolerance value in the unit used for linear dimensions. This value is preceded by the symbol \varnothing if the tolerance zone is circular or cylindrical; or by the symbol “S \varnothing ” if the tolerance zone is spherical;
- if appropriate, the capital letter or letters identifying the datum feature or features (see figures 4, 5 and 6).

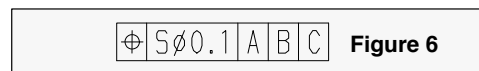
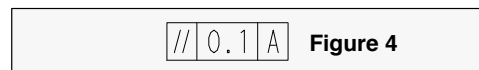
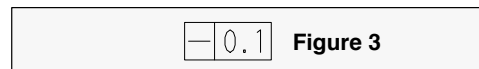

Remarks referred to the tolerance, for example “6 holes”, “4 surfaces”, or “6 x” shall be written above the frame (see figures 7 and 8).

If it is necessary to specify more than one tolerance characteristic for a feature, the tolerance specifications are given in tolerance frames one under the other (see figure 9).

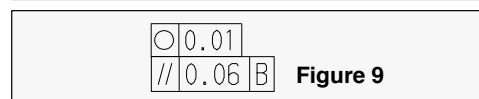
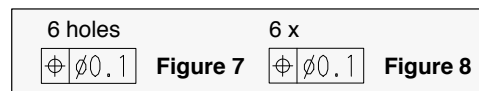

Table 1: Kinds of tolerances; symbols; included tolerances

Tolerances	Toleranced characteristics	Symbols	Included tolerances	
Form tolerances	Straightness		-	
	Flatness		Straightness	
	Circularity (Roundness)		-	
	Cylindricity		Straightness, Parallelism, Circularity	
Profile tolerances	Profile any line		-	
	Profile any surface		-	
Tolerances of position	Orientation tolerances	Parallelism		Flatness
		Perpendicularity		Flatness
		Angularity		Flatness
	Location tolerances	Position		-
		Concentricity (for centre points), Coaxiality (for axes)		-
		Symmetry		Straightness, Flatness, Parallelism
	Runout tolerances	Circular runout		Circularity, Coaxiality, Concentricity
		Total runout		Concentricity, Coaxiality, Flatness, Parallelism, Perpendicularity

Table 2: Additional symbols

Description		Symbols
Toleranced feature indications	direct	
	by letter	
Datum feature indication (by letter only)		
Datum target indication	$\varnothing 2$ = Dimension of the target area A1 = Datum feature and datum target number	
Theoretically exact dimension		
Projected tolerance zone		
Maximum material requirement Dependent on dimensional, form, and position tolerances		
Least material requirement Dimension describing the least material state of a form feature		
Free state condition (non-rigid parts)		
Envelope requirement: The maximum material dimension must not breach a geometrically ideal envelope.		

5.8 Toleranced features

The tolerance frame is connected to the toleranced feature by a leader line terminating with an arrow in the following way:

- on the outline of the feature or an extension of the outline (but clearly separated from the dimension line) when the tolerance refers to the line or surface itself (see figures 10 and 11).

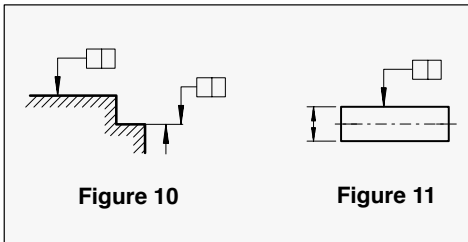

Figure 10

Figure 11

- as an extension of a dimension line when the tolerance refers to the axis or median plane defined by the feature so dimensioned (see figures 12 to 14).

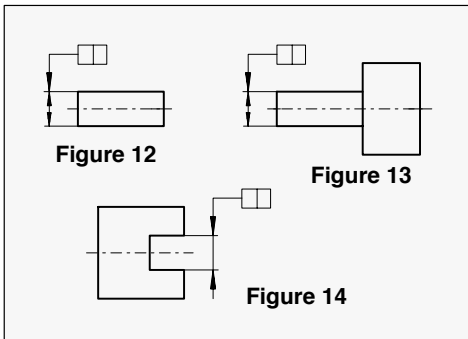

Figure 12

Figure 13

Figure 14

- on the axis or the median plane when the tolerance refers to the common axis or median plane of two or more features (see figure 15).

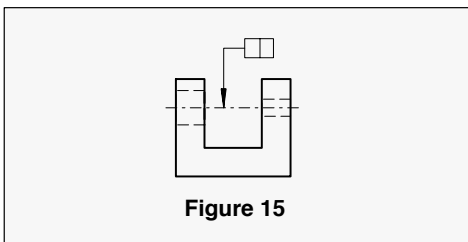

Figure 15

Note:

Whether a tolerance should be applied to the contour of a cylindrical or symmetrical feature or to its axis or median plane, depends on the functional requirements.

5.9 Tolerance zones

The tolerance zone is the zone within which all the points of a geometric feature (point, line, surface, median plane) must lie. The width of the tolerance zone is in the direction of the arrow of the leader line joining the tolerance frame to the feature which is toleranced, unless the tolerance value is preceded by the symbol \varnothing (see figures 16 and 17).

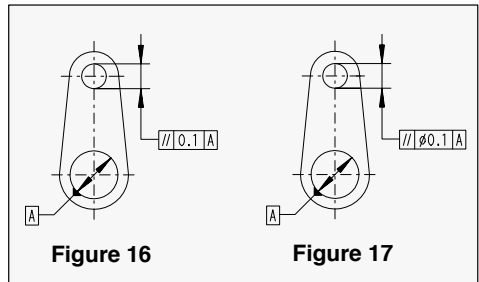

Figure 16

Figure 17

Where a common tolerance zone is applied to several separate features, the requirement is indicated by the words "common zone" above the tolerance frame (see figure 18).

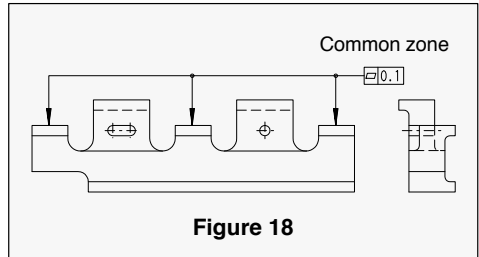

Figure 18

5.10 Datums and datum systems

Datum features are features according to which a workpiece is aligned for recording the toleranced deviations.

5.10.1 When a toleranced feature is referred to a datum, this is generally shown by datum letters. The same letter which defines the datum is repeated in the tolerance frame.

To identify the datum, a capital letter enclosed in a frame is connected to a datum triangle (see figures 19a and 19b).

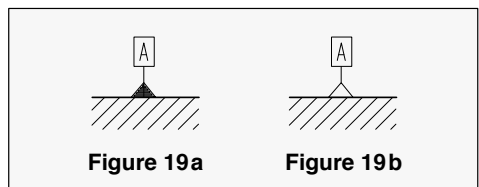

Figure 19a

Figure 19b

The datum triangle with the datum letter is placed:

- on the outline of the feature or an extension of the outline (but clearly separated from the dimension line), when the datum feature is the line or surface itself (see figure 20).

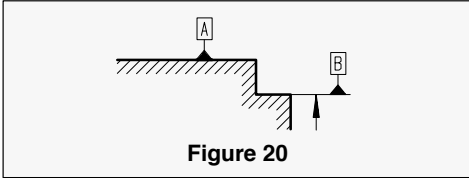

Figure 20

- as an extension of the dimension line when the datum feature is the axis or median plane (see figures 21 and 22).

Note:

If there is not enough space for two arrows, one of them may be replaced by the datum triangle (see figure 22).

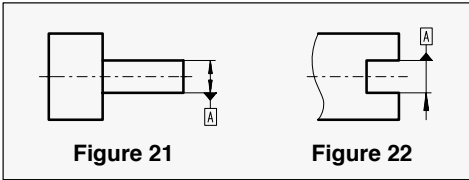

Figure 21

Figure 22

- on the axis or median plane when the datum is:
 - a) the axis or median plane of a single feature (for example a cylinder);
 - b) the common axis or median plane formed by two features (see figure 23).

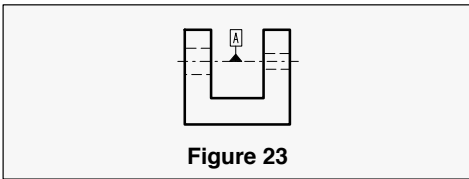

Figure 23

If the tolerance frame can be directly connected with the datum feature by a leader line, the datum letter may be omitted (see figures 24 and 25).

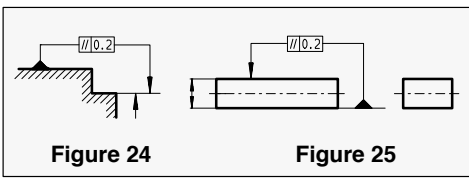

Figure 24

Figure 25

A single datum is identified by a capital letter (see figure 26).

A common datum formed by two datum features is identified by two datum letters separated by a hyphen (see figures 27 and 29).

In a datum system (see also 5.10.2) the sequence of two or more datum features is important. The datum letters are to be placed in different compartments, where the sequence from left to right shows the order of priority, and the datum letter placed first should refer to the directional datum feature (see figures 28, 30 and 31).

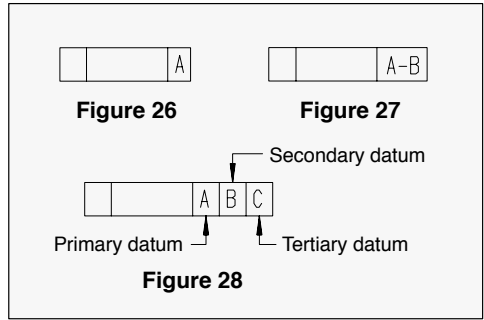

Figure 26

Figure 27

Figure 28

5.10.2 Datum system

A datum system is a group of two or more datums to which one tolerated feature refers in common. A datum system is frequently required because the direction of a short axis cannot be determined alone.

Datum formed by two form features (common datum):

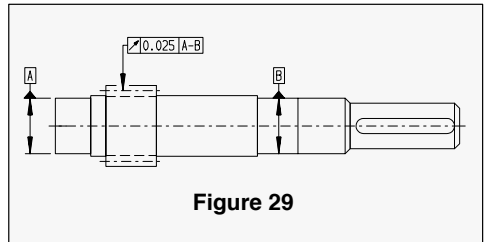

Figure 29

Datum system formed by two datums (directional datum "A" and short axis "B").

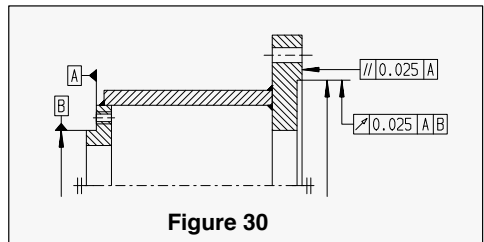

Figure 30

Datum system formed by one plane and one perpendicular axis of a cylinder:

Datum "A" is the plane formed by the plane contact surface. Datum "B" is the axis of the largest inscribed cylinder, the axis being at right angles with datum "A" (see figure 31).

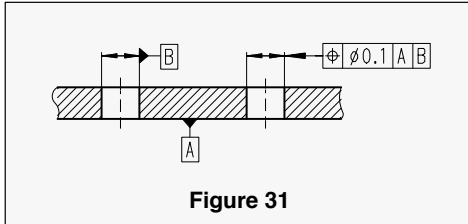

Figure 31

5.11 Theoretically exact dimensions

If tolerances of position or angularity are prescribed for a feature, the dimensions determining the theoretically exact position or angle shall not be tolerated.

These dimensions are enclosed, for example $\boxed{30}$. The corresponding actual dimensions of the part are subject only to the position tolerance or angu-

larity tolerance specified within the tolerance frame (see figures 32 and 33).

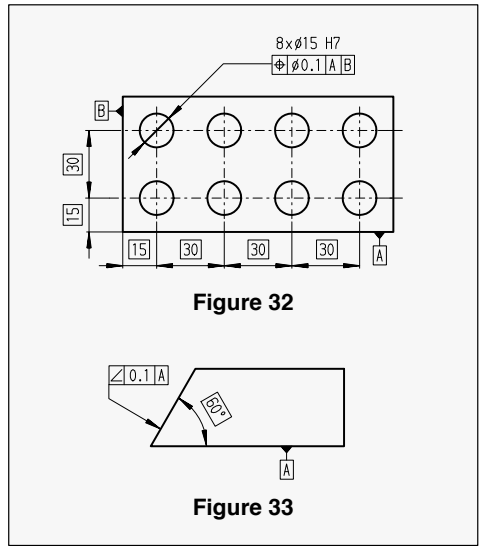
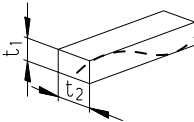
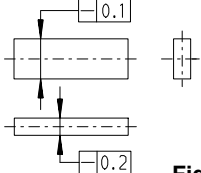
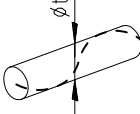
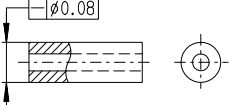

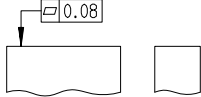
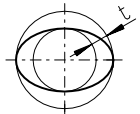
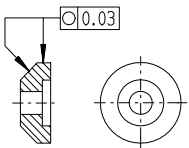
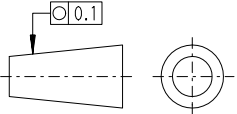



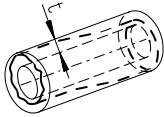
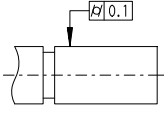

Figure 32

Figure 33



5.12 Definitions of tolerances

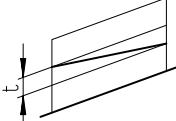
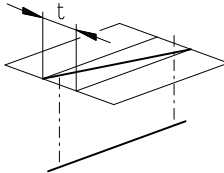
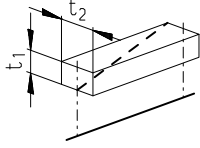
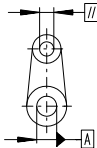
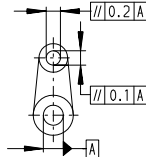

Symbol	Definition of the tolerance zone	Indication and interpretation
—	<p>5.12.1 Straightness tolerance</p> <p>The tolerance zone when projected in a plane is limited by two parallel straight lines a distance t apart.</p> <p>Figure 34</p>	<p>Any line on the upper surface parallel to the plane of projection in which the indication is shown shall be contained between two parallel straight lines 0.1 apart.</p> <p>Figure 35</p>
	<p>Any portion of length 200 of any generator of the cylindrical surface indicated by the arrow shall be contained between two parallel straight lines 0.1 apart in a plane containing the axis.</p> <p>Figure 36</p>	

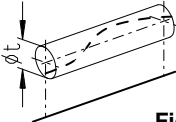
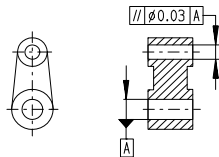
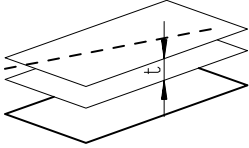
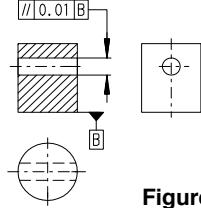
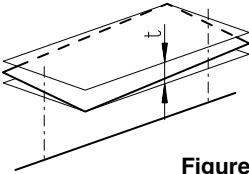
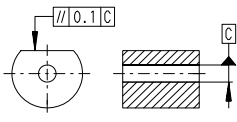
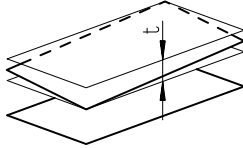
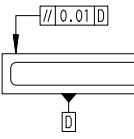
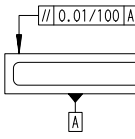

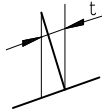
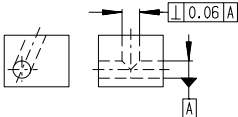
Symbol	Definition of the tolerance zone	Indication and interpretation
—	<p>The tolerance zone is limited by a parallelepiped of section $t_1 \cdot t_2$ if the tolerance is specified in two directions perpendicular to each other.</p>  <p style="text-align: center;">Figure 37</p>	<p>The axis of the bar shall be contained within a parallelepipedic zone of width 0.1 in the vertical and 0.2 in the horizontal direction.</p>  <p style="text-align: right;">Figure 38</p>
	<p>The tolerance zone is limited by a cylinder of diameter t if the tolerance value is preceded by the symbol \varnothing.</p>  <p style="text-align: center;">Figure 39</p>	<p>The axis of the cylinder to which the tolerance frame is connected shall be contained in a cylindrical zone of diameter 0.08.</p>  <p style="text-align: right;">Figure 40</p>
5.12.2 Flatness tolerance		
□	<p>The tolerance zone is limited by two parallel planes a distance t apart.</p>  <p style="text-align: center;">Figure 41</p>	<p>The surface shall be contained between two parallel planes 0.08 apart.</p>  <p style="text-align: right;">Figure 42</p>
5.12.3 Circularity tolerance		
○	<p>The tolerance zone in the considered plane is limited by two concentric circles a distance t apart.</p>  <p style="text-align: center;">Figure 43</p>	<p>The circumference of each cross-section of the outside diameter shall be contained between two co-planar concentric circles 0.03 apart.</p>  <p style="text-align: right;">Figure 44</p> <p>The circumference of each cross-section shall be contained between two co-planar concentric circles 0.1 apart.</p>  <p style="text-align: right;">Figure 45</p>

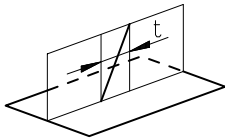
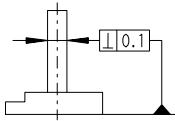
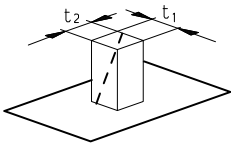
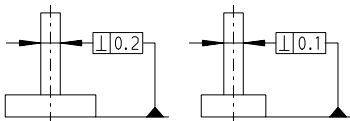
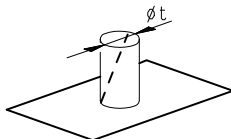
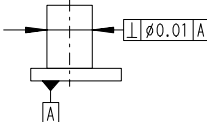

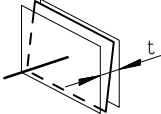
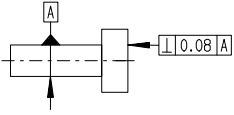
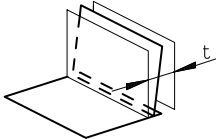
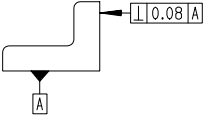
Symbol	Definition of the tolerance zone	Indication and interpretation
	<p>5.12.4 Cylindricity tolerance</p> <p>The tolerance zone is limited by two coaxial cylinders a distance t apart.</p>  <p style="text-align: center;">Figure 46</p>	<p>The considered surface area shall be contained between two coaxial cylinders 0.1 apart.</p>  <p style="text-align: center;">Figure 47</p>
		<p>5.12.5 Parallelism tolerance</p> <p>Parallelism tolerance of a line with reference to a datum line</p> <p>The tolerance zone when projected in a plane is limited by two parallel straight lines a distance t apart and parallel to the datum line, if the tolerance zone is only specified in one direction.</p>  <p style="text-align: center;">Figure 48</p>  <p style="text-align: center;">Figure 51</p>
<p>The tolerance zone is limited by a parallelepiped of section $t_1 \cdot t_2$ and parallel to the datum line if the tolerance is specified in two planes perpendicular to each other.</p>  <p style="text-align: center;">Figure 53</p>		<p>The tolerated axis shall be contained in a parallelepipedic tolerance zone having a width of 0.2 in the horizontal and 0.1 in the vertical direction and which is parallel to the datum axis A (see figures 54 and 55).</p>  <p style="text-align: center;">Figure 54</p>  <p style="text-align: center;">Figure 55</p>

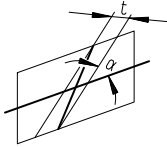
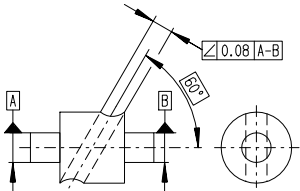
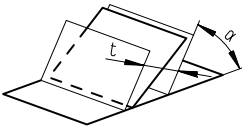
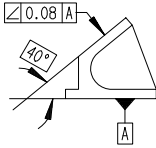

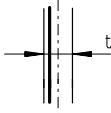
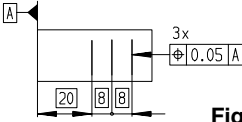
Symbol	Definition of the tolerance zone	Indication and interpretation
	<p>Parallelism tolerance of a line with reference to a datum line</p> <p>The tolerance zone is limited by a cylinder of diameter t parallel to the datum line if the tolerance value is preceded by the symbol \varnothing.</p>  <p style="text-align: center;">Figure 56</p>	<p>The tolerated axis shall be contained in a cylindrical zone of diameter 0.03 parallel to the datum axis A (datum line).</p>  <p style="text-align: center;">Figure 57</p>
	<p>Parallelism tolerance of a line with reference to a datum surface</p> <p>The tolerance zone is limited by two parallel planes a distance t apart and parallel to the datum surface.</p>  <p style="text-align: center;">Figure 58</p>	<p>The tolerated axis of the hole shall be contained between two planes 0.01 apart and parallel to the datum surface B.</p>  <p style="text-align: center;">Figure 59</p>
//	<p>Parallelism tolerance of a surface with reference to a datum line</p> <p>The tolerance zone is limited by two parallel planes a distance t apart and parallel to the datum line.</p>  <p style="text-align: center;">Figure 60</p>	<p>The tolerated surface shall be contained between two planes 0.1 apart and parallel to the datum axis C of the hole.</p>  <p style="text-align: center;">Figure 61</p>
	<p>Parallelism tolerance of a surface with reference to a datum surface</p> <p>The tolerance zone is limited by two parallel planes a distance t apart and parallel to the datum surface.</p>  <p style="text-align: center;">Figure 62</p>	<p>The tolerated surface shall be contained between two parallel planes 0.01 apart and parallel to the datum surface D (figure 63).</p>  <p style="text-align: center;">Figure 63</p> <p>The tolerated surface shall be contained between two parallel planes 0.01/100 apart and parallel to the datum surface A (figure 64).</p>  <p style="text-align: center;">Figure 64</p> <p>All the points of the tolerated surface in a length of 100, placed anywhere on this surface, shall be contained between two parallel planes 0.01 apart and parallel to the datum surface A (figure 64).</p>

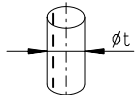
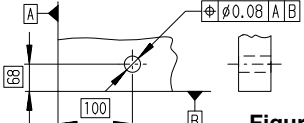
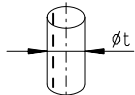
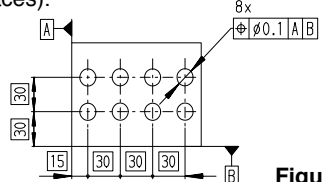
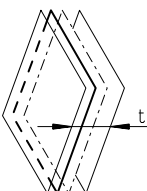
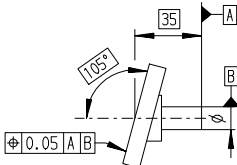

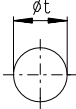
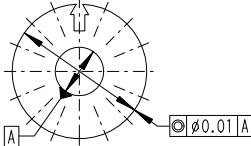
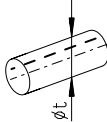
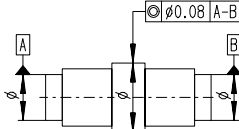
Symbol	Definition of the tolerance zone	Indication and interpretation
5.12.6 Perpendicularity tolerance		
Perpendicularity tolerance of a line with reference to a datum line		
	<p>The tolerance zone when projected in a plane is limited by two parallel straight lines a distance t apart and perpendicular to the datum line.</p>  <p style="text-align: center;">Figure 65</p>	<p>The tolerated axis of the inclined hole shall be contained between two parallel planes 0.06 apart and perpendicular to the axis of the horizontal hole A (datum line).</p>  <p style="text-align: center;">Figure 66</p>
Perpendicularity tolerance of a line with reference to a datum surface		
	<p>The tolerance zone when projected in a plane is limited by two parallel straight lines a distance t apart and perpendicular to the datum plane if the tolerance is specified only in one direction.</p>  <p style="text-align: center;">Figure 67</p>	<p>The tolerated axis of the cylinder, to which the tolerance frame is connected, shall be contained between two parallel planes 0.1 apart, perpendicular to the datum surface.</p>  <p style="text-align: center;">Figure 68</p>
	<p>The tolerance zone is limited by a parallelepiped of section $t_1 \cdot t_2$ and perpendicular to the datum surface if the tolerance is specified in two directions perpendicular to each other.</p>  <p style="text-align: center;">Figure 69</p>	<p>The tolerated axis of the cylinder shall be contained in a parallelepipedic tolerance zone of $0.1 \cdot 0.2$ which is perpendicular to the datum surface.</p>  <p style="text-align: center;">Figure 70</p>
	<p>The tolerance zone is limited by a cylinder of diameter t perpendicular to the datum surface if the tolerance value is preceded by the symbol \varnothing.</p>  <p style="text-align: center;">Figure 71</p>	<p>The tolerated axis of the cylinder to which the tolerance frame is connected shall be contained in a cylindrical zone of diameter 0.01 perpendicular to the datum surface A.</p>  <p style="text-align: center;">Figure 72</p>

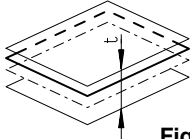
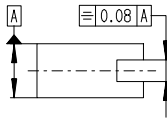
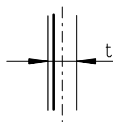
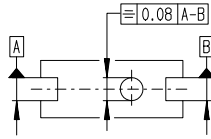
Symbol	Definition of the tolerance zone	Indication and interpretation
	<p>Perpendicularity tolerance of a surface with reference to a datum line</p> <p>The tolerance zone is limited by two parallel planes a distance t apart and perpendicular to the datum line.</p>  <p style="text-align: center;">Figure 73</p>	<p>The tolerated face of the workpiece shall be contained between two parallel planes 0.08 apart and perpendicular to the axis A (datum line).</p>  <p style="text-align: center;">Figure 74</p>
	<p>Perpendicularity tolerance of a surface with reference to a datum surface</p> <p>The tolerance zone is limited by two parallel planes a distance t apart and perpendicular to the datum surface.</p>  <p style="text-align: center;">Figure 75</p>	<p>The tolerated surface shall be contained between two parallel planes 0.08 apart and perpendicular to the horizontal datum surface A.</p>  <p style="text-align: center;">Figure 76</p>
	<p>5.12.7 Angularity tolerance</p>	
	<p>Angularity tolerance of a line with reference to a datum line</p>	
	<p>Line and datum line in the same plane. The tolerance zone when projected in a plane is limited by two parallel straight lines a distance t apart and inclined at the specified angle to the datum line.</p>  <p style="text-align: center;">Figure 77</p>	<p>The tolerated axis of the hole shall be contained between two parallel straight lines 0.08 apart which are inclined at 60° to the horizontal axis A - B (datum line).</p>  <p style="text-align: center;">Figure 78</p>
<p>Angularity tolerance of a surface with reference to a datum surface</p>		
<p>The tolerance zone is limited by two parallel planes a distance t apart and inclined at the specified angle to the datum surface.</p>  <p style="text-align: center;">Figure 79</p>	<p>The tolerated surface shall be contained between two parallel planes 0.08 apart which are inclined at 40° to the datum surface A.</p>  <p style="text-align: center;">Figure 80</p>	

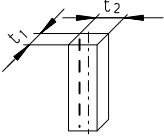
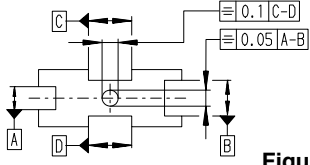
Symbol	Definition of the tolerance zone	Indication and interpretation
<p>5.12.8 Positional tolerance</p>		
<p>Positional tolerance of a line</p>		
	<p>The tolerance zone when projected in a plane is limited by two parallel straight lines a distance t apart and disposed symmetrically with respect to the theoretically exact position of the considered line if the tolerance is specified only in one direction.</p>  <p style="text-align: center;">Figure 81</p>	<p>Each of the tolerated lines shall be contained between two parallel straight lines 0.05 apart which are symmetrically disposed about the theoretically exact position of the considered line, with reference to the surface A (datum surface).</p>  <p style="text-align: right;">Figure 82</p>
	<p>The tolerance zone is limited by a cylinder of diameter t the axis of which is in the theoretically exact position of the considered line if the tolerance value is preceded by the symbol \varnothing.</p>  <p style="text-align: center;">Figure 83</p>	<p>The axis of the hole shall be contained within a cylindrical zone of diameter 0.08 the axis of which is in the theoretically exact position of the considered line, with reference to the surfaces A and B (datum surfaces).</p>  <p style="text-align: right;">Figure 84</p>
	<p>The tolerance zone is limited by a cylinder of diameter t the axis of which is in the theoretically exact position of the considered line if the tolerance value is preceded by the symbol \varnothing.</p>  <p style="text-align: center;">Figure 83</p>	<p>Each of the axes of the eight holes shall be contained within a cylindrical zone of diameter 0.1 the axis of which is in the theoretically exact position of the considered hole, with reference to the surfaces A and B (datum surfaces).</p>  <p style="text-align: right;">Figure 85</p>
<p>Positional tolerance of a flat surface or a median plane</p>		
	<p>The tolerance zone is limited by two parallel planes a distance t apart and disposed symmetrically with respect to the theoretically exact position of the considered surface.</p>  <p style="text-align: center;">Figure 86</p>	<p>The inclined surface shall be contained between two parallel planes which are 0.05 apart and which are symmetrically disposed with respect to the theoretically exact position of the considered surface with reference to the datum surface A and the axis of the datum cylinder B (datum line).</p>  <p style="text-align: right;">Figure 87</p>

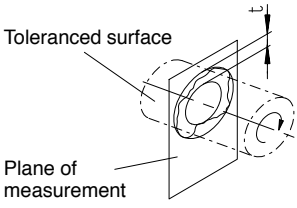
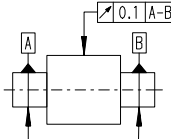
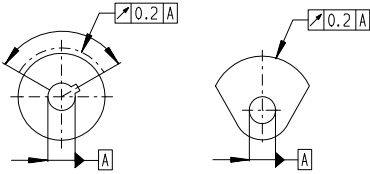
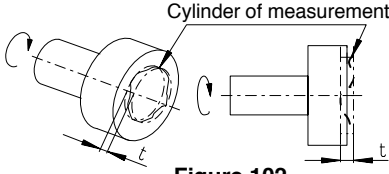
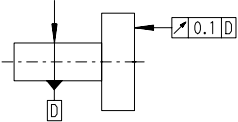
Symbol	Definition of the tolerance zone	Indication and interpretation
	<p>5.12.9 Concentricity and coaxiality tolerance</p>	
	<p>Concentricity tolerance of a point</p>	
	<p>The tolerance zone is limited by a circle of diameter t the centre of which coincides with the datum point.</p>  <p style="text-align: center;">Figure 88</p>	<p>The centre of the circle, to which the tolerance frame is connected, shall be contained in a circle of diameter 0.01 concentric with the centre of the datum circle A.</p>  <p style="text-align: right;">Figure 89</p>
	<p>Coaxiality tolerance of an axis</p>	
<p>The tolerance zone is limited by a cylinder of diameter t, the axis of which coincides with the datum axis if the tolerance value is preceded by the symbol \emptyset.</p>  <p style="text-align: center;">Figure 90</p>	<p>The axis of the cylinder, to which the tolerance frame is connected, shall be contained in a cylindrical zone of diameter 0.08 coaxial with the datum axis A - B.</p>  <p style="text-align: right;">Figure 91</p>	
	<p>5.12.10 Symmetry</p>	
	<p>Symmetry tolerance of a median plane</p>	
	<p>The tolerance zone is limited by two parallel planes a distance t apart and disposed symmetrically to the median plane with respect to the datum axis or datum plane.</p>  <p style="text-align: center;">Figure 92</p>	<p>The median plane of the slot shall be contained between two parallel planes, which are 0.08 apart and symmetrically disposed about the median plane with respect to the datum feature A.</p>  <p style="text-align: center;">Figure 93</p>
	<p>Symmetry tolerance of a line or an axis</p>	
<p>The tolerance zone when projected in a plane is limited by two parallel straight lines a distance t apart and disposed symmetrically with respect to the datum axis (or datum plane) if the tolerance is specified only in one direction.</p>  <p style="text-align: center;">Figure 94</p>	<p>The axis of the hole shall be contained between two parallel planes which are 0.08 apart and symmetrically disposed with respect to the actual common median plane of the datum slots A and B.</p>  <p style="text-align: center;">Figure 95</p>	

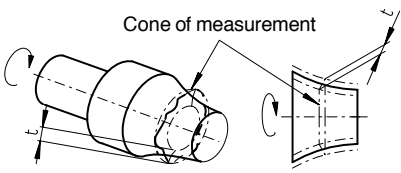
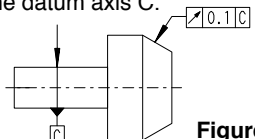
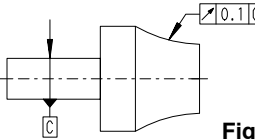
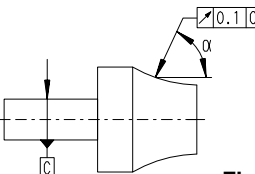
Symbol	Definition of the tolerance zone	Indication and interpretation
	<p>Symmetry tolerance of a line or an axis</p> <p>The tolerance zone is limited by a parallelepiped of section $t_1 \cdot t_2$, the axis of which coincides with the datum axis if the tolerance is specified in two directions perpendicular to each other.</p>  <p style="text-align: center;">Figure 96</p>	<p>The axis of the hole shall be contained in a parallelepipedic zone of width 0.1 in the horizontal and 0.05 in the vertical direction and the axis of which coincides with the datum axis formed by the intersection of the two median planes of the datum slots A-B and C-D.</p>  <p style="text-align: right;">Figure 97</p>
	<p>5.12.11 Circular runout tolerance</p> <p>Circular runout tolerance - radial</p> <p>The tolerance zone is limited within any plane of measurement perpendicular to the axis by two concentric circles a distance t apart, the centre of which coincides with the datum axis.</p>  <p style="text-align: center;">Figure 98</p> <p>Runout normally applies to complete revolutions about the axis but could be limited to apply to a part of a revolution.</p>	<p>The radial runout shall not be greater than 0.1 in any plane of measurement during one revolution about the datum axis A - B.</p>  <p style="text-align: right;">Figure 99</p> <p>The radial runout shall not be greater than 0.2 in any plane of measurement when measuring the toleranced part of a revolution about the centre line of hole A (datum axis).</p>  <p style="text-align: center;">Figure 100 Figure 101</p>
	<p>Circular runout tolerance - axial</p> <p>The tolerance zone is limited at any radial position by two circles a distance t apart lying in a cylinder of measurement, the axis of which coincides with the datum axis.</p>  <p style="text-align: center;">Figure 102</p>	<p>The axial runout shall not be greater than 0.1 at any position of measurement during one revolution about the datum axis D.</p>  <p style="text-align: right;">Figure 103</p>

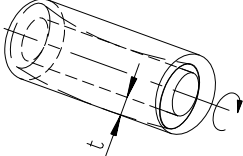
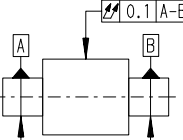
Symbol	Definition of the tolerance zone	Indication and interpretation
	<p>Circular runout tolerance in any direction</p> <p>The tolerance zone is limited within any cone of measurement, the axis of which coincides with the datum axis by two circles a distance t apart. Unless otherwise specified the measuring direction is normal to the surface.</p>  <p style="text-align: center;">Figure 104</p>	<p>The runout in the direction indicated by the arrow shall not be greater than 0.1 in any cone of measurement during one revolution about the datum axis C.</p>  <p style="text-align: right;">Figure 105</p> <p>The runout in the direction perpendicular to the tangent of a curved surface shall not be greater than 0.1 in any cone of measurement during one revolution about the datum axis C.</p>  <p style="text-align: right;">Figure 106</p>
	<p>Circular runout tolerance in a specified direction</p> <p>The tolerance zone is limited within any cone of measurement of the specified angle, the axis of which coincides with the datum axis by two circles a distance t apart.</p>	<p>The runout in the specified direction shall not be greater than 0.1 in any cone of measurement during one revolution about the datum axis C.</p>  <p style="text-align: right;">Figure 107</p>
	<p>5.12.12 Total runout tolerance</p> <p>Total radial runout tolerance</p> <p>The tolerance zone is limited by two coaxial cylinders a distance t apart, the axes of which coincide with the datum axis.</p>  <p style="text-align: center;">Figure 108</p>	<p>The total radial runout shall not be greater than 0.1 at any point on the specified surface during several revolutions about the datum axis A-B, and with relative axial movement between part and measuring instrument. With relative movement the measuring instrument or the workpiece shall be guided along a line having the theoretically perfect form of the contour and being in correct position to the datum axis.</p>  <p style="text-align: right;">Figure 109</p>

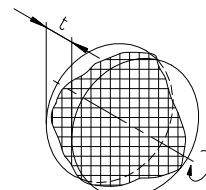
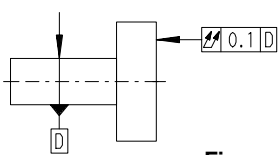
Symbol	Definition of the tolerance zone	Indication and interpretation
	<p>Total axial runout tolerance</p> <p>The tolerance zone is limited by two parallel planes a distance t apart and perpendicular to the datum axis.</p>  <p>Figure 110</p>	<p>The total axial runout shall not be greater than 0.1 at any point on the specified surface during several revolutions about the datum axis D and with relative radial movement between the measuring instrument and the part. With relative movement the measuring instrument or the workpiece shall be guided along a line having the theoretically perfect form of the contour and being in correct position to the datum axis.</p>  <p>Figure 111</p>

Technical drawings, extract from DIN EN ISO 5457.

created by CAD. This standard may also be used for other technical documents. The sheet sizes listed below have been taken from DIN EN ISO 5457.

6. Sheet sizes

The DIN EN ISO 5457 standard applies to the presentation of drawing forms even if they are

Table 3 Formats of trimmed and untrimmed sheets and of the drawing area

Sheet sizes acc. to DIN EN ISO 5457, A series	Trimmed sheet $a_1 \times b_1$ mm	Drawing area ¹⁾ $a_2 \times b_2$ mm	Untrimmed sheet $a_3 \times b_3$ mm
A 0	841 x 1189	821 x 1159	880 x 1230
A 1	594 x 841	574 x 811	625 x 880
A 2	420 x 594	400 x 564	450 x 625
A 3	297 x 420	277 x 390	330 x 450
A 4	210 x 297	180 x 277	240 x 330

1) The actually available drawing area is reduced by the title block, the filing margin, the possible sectioning margin, etc.

6.1 Title block

Formats \geq A3 are produced in broadside. The title block area is in the bottom right corner of the trimmed sheet. For the A4 format the title block area is at the bottom of the short side (upright format).

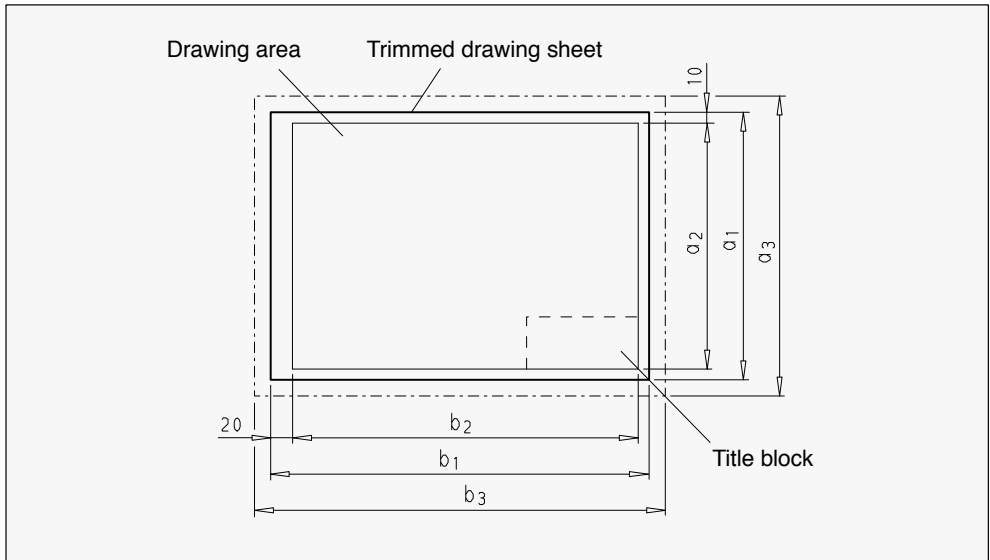

6.2 Non-standard formats

Non-standard formats should be avoided. When necessary they should be created using the

dimensions of the short side of an A-format with the long side of a greater A-format.

7. Type sizes

Table 4: Type sizes for drawing formats (h = type height, b = line width)

Application range for lettering	Paper sizes			
	A0 and A1		A2, A3 and A4	
	h	b	h	b
Type, drawing no.	10	1	7	0.7
Texts and nominal dimensions	5	0.5	3.5	0.35
Tolerances, roughness values, symbols	3.5	0.35	2.5	0.25

7.1 The type sizes as assigned to the paper sizes in table 4 MUST be adhered to with regard to their application range. Larger type heights are

also permissible. Type heights smaller by approx. 20% will be accepted if this is required in a drawing because of restricted circumstances.

8. Lines acc. to DIN ISO 128, Part 20 and Part 24

Table 5: Line groups, line types and line widths

Line group	0.5	0.7
Drawing format	A4, A3, A2	A1, A0
Line type	Line width	
Solid line (thick)	0.5	0.7
Solid line (thin)	0.25	0.35
Short dashes (thin)	0.25	0.35
Dot-dash line (thick)	0.5	0.7
Dot-dash line (thin)	0.25	0.35
Dash/double-dot line (thin)	0.25	0.35
Freehand (thin)	0.25	0.35

8.1 Line groups 0.5 and 0.7 with the pertaining line width according to table 5 may only be used. Assignment to the drawing formats A1 and

A0 is prescribed. For the A4, A3 and A2 formats, line group 0.7 may be used as well.

9. Lettering example

9.1 Example for formats A4 to A2

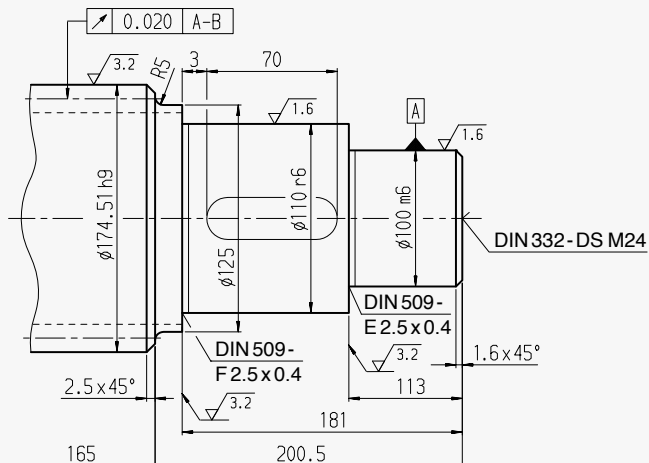

Table of Contents Section 2

Standardization	Page
ISO Metric Screw Threads (Coarse Pitch Threads)	25
ISO Metric Screw Threads (Coarse and Fine Pitch Threads)	26
Cylindrical Shaft Ends	27
ISO Tolerance Zones, Allowances, Fit Tolerances; Inside Dimensions (Holes)	28
ISO Tolerance Zones, Allowances, Fit Tolerances; Outside Dimensions (Shafts)	29
Parallel Keys, Taper Keys, and Centre Holes	30

Standardization

ISO Metric Screw Threads (Coarse Pitch Threads)

ISO metric screw threads (coarse pitch threads) following DIN 13, Part 1

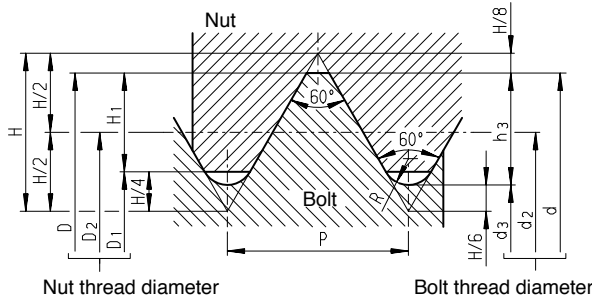

$$D_1 = d - 2 H_1$$

$$d_2 = D_2 = d - 0.64952 P$$

$$d_3 = d - 1.22687 P$$

$$H = 0.86603 P$$

$$H_1 = 0.54127 P$$

$$h_3 = 0.61343 P$$

$$R = \frac{H}{6} = 0.14434 P$$

Diameters of series 1 should be preferred to those of series 2, and these again to those of series 3.

Nominal thread diameter			Pitch P mm	Pitch diameter d ₂ = D ₂ mm	Core diameter		Depth of thread		Round R mm	Tensile stress cross-section A _s ¹⁾ mm ²
Series 1 d = D	Series 2	Series 3			d ₃ mm	D ₁ mm	h ₃ mm	H ₁ mm		
3			0.5	2.675	2.387	2.459	0.307	0.271	0.072	5.03
	3.5		0.6	3.110	2.764	2.850	0.368	0.325	0.087	6.78
4			0.7	3.545	3.141	3.242	0.429	0.379	0.101	8.78
	4.5		0.75	4.013	3.580	3.688	0.460	0.406	0.108	11.3
5			0.8	4.480	4.019	4.134	0.491	0.433	0.115	14.2
6			1	5.350	4.773	4.917	0.613	0.541	0.144	20.1
		7	1	6.350	5.773	5.917	0.613	0.541	0.144	28.9
8			1.25	7.188	6.466	6.647	0.767	0.677	0.180	36.6
		9	1.25	8.188	7.466	7.647	0.767	0.677	0.180	48.1
10			1.5	9.026	8.160	8.376	0.920	0.812	0.217	58.0
		11	1.5	10.026	9.160	9.376	0.920	0.812	0.217	72.3
12			1.75	10.863	9.853	10.106	1.074	0.947	0.253	84.3
	14		2	12.701	11.546	11.835	1.227	1.083	0.289	115
16			2	14.701	13.546	13.835	1.227	1.083	0.289	157
	18		2.5	16.376	14.933	15.294	1.534	1.353	0.361	193
20			2.5	18.376	16.933	17.294	1.534	1.353	0.361	245
	22		2.5	20.376	18.933	19.294	1.534	1.353	0.361	303
24			3	22.051	20.319	20.752	1.840	1.624	0.433	353
	27		3	25.051	23.319	23.752	1.840	1.624	0.433	459
30			3.5	27.727	25.706	26.211	2.147	1.894	0.505	561
	33		3.5	30.727	28.706	29.211	2.147	1.894	0.505	694
36			4	33.402	31.093	31.670	2.454	2.165	0.577	817
	39		4	36.402	34.093	34.670	2.454	2.165	0.577	976
42			4.5	39.077	36.479	37.129	2.760	2.436	0.650	1121
	45		4.5	42.077	39.479	40.129	2.760	2.436	0.650	1306
48			5	44.752	41.866	42.587	3.067	2.706	0.722	1473
	52		5	48.752	45.866	46.587	3.067	2.706	0.722	1758
56			5.5	52.428	49.252	50.046	3.374	2.977	0.794	2030
	60		5.5	56.428	53.252	54.046	3.374	2.977	0.794	2362
64			6	60.103	56.639	57.505	3.681	3.248	0.866	2676
	68		6	64.103	60.639	61.505	3.681	3.248	0.866	3055

1) The tensile stress cross-section is calculated acc. to DIN 13 Part 28 with formula

$$A_s = \frac{\pi}{4} \cdot \left(\frac{d_2 + d_3}{2} \right)^2$$

Standardization

ISO Metric Screw Threads

(Coarse and Fine Pitch Threads)

Selection of nominal thread diameters and pitches for coarse and fine pitch threads from 1 mm to 68 mm diameter, following DIN ISO 261

Nominal thread diameter $d = D$			Coarse pitch thread	Pitches P for fine pitch threads							
Series 1	Series 2	Series 3		4	3	2	1.5	1.25	1	0.75	0.5
1 1.2	1.4		0.25 0.25 0.3								
1.6 2	1.8		0.35 0.35 0.4								
2.5 3	2.2		0.45 0.45 0.5								
4 5	3.5		0.6 0.7 0.8								0.5 0.5
6 8 10			1 1.25 1.5					1.25	1 1	0.75 0.75 0.75	0.5 0.5
12	14	15	1.75 2				1.5 1.5 1.5	1.25 1.25	1 1 1		
16	18	17	2 2.5				1.5 1.5		1 1 1		
20 24	22		2.5 2.5 3			2 2 2	1.5 1.5 1.5		1 1 1		
	27	25 26	3				1.5 1.5 1.5				
30		28 32	3.5			2	1.5 1.5 1.5				
36	33	35	3.5 4			2 2	1.5 1.5 1.5				
	39	38 40	4		3	2	1.5 1.5				
42 48	45		4.5 4.5 5		3 3 3	2 2 2	1.5 1.5 1.5				
	52	50 55	5		3	2 2	1.5 1.5 1.5				
56	60	58	5.5 5.5	4 4	3 3	2 2	1.5 1.5 1.5				
64	68	65	6 6	4 4	3 3	2 2 2					

Standardization

Cylindrical Shaft Ends

Cylindrical shaft ends							
Acc. to DIN 748/1					FLENDER works standard W 0470		
Dia-meter Series		ISO tolerance zone	Length		Dia-meter	Length	ISO tolerance zone
1	2		Long	Short			
mm	mm		mm	mm	mm	mm	
6		k6	16				
7			16				
8			20				
9			20				
10			23	15			
11			23	15			
12			30	18			
14			30	18	14	30	
16			40	28	16	30	
19			40	28	19	35	k6
20			50	36	20	35	k6
22			50	36	22	35	k6
24			50	36	24	40	
25			60	42	25	40	
28			60	42	28	50	
30			80	58	30	50	
32			80	58	32	60	
35			80	58	35	60	
38			80	58	38	60	
40			110	82	40	70	
42			110	82	42	70	
45			110	82	45	80	
48		110	82	48	80		
50		110	82	50	80		
55		110	82	55	90	m6	
60		140	105	60	105		
65		140	105	65	105		
70		140	105	70	120		
75	m6	140	105	75	120		
80		170	130	80	140		
85		170	130	85	140		
90		170	130	90	160		
95		170	130	95	160		

Cylindrical shaft ends							
Acc. to DIN 748/1					FLENDER works standard W 0470		
Dia-meter Series		ISO tolerance zone	Length		Dia-meter	Length	ISO tolerance zone
1	2		Long	Short			
mm	mm		mm	mm	mm	mm	
100		m6	210	165	100	180	m6
110			210	165	110	180	
120			210	165	120	210	
130			250	200	130	210	
140			250	200	140	240	
150			250	200	150	240	
160			300	240	160	270	
170			300	240	170	270	
180			300	240	180	310	
190			350	280	190	310	
200			350	280	200	310	
220			350	280	220	350	
240			410	330	240	400	
250			410	330	250	400	
260			410	330	260	400	
280			470	380	280	450	n6
300	m6		470	380	300	500	
320			470	380	320	500	
340			550	450	340	550	
360			550	450	360	590	
380			550	450	380	590	
400			650	540	400	650	
420		650	540	420	650		
440		650	540	440	690		
450		650	540	450	750		
460		650	540	460	750		
480		650	540	480	790		
500		650	540	500	790		
530		800	680				
560		800	680				
600		800	680				
630		800	680				

Standardization

ISO Tolerance Zones, Allowances, Fit Tolerances

Inside Dimensions (Holes)

**ISO tolerance zones, allowances, fit tolerances; Inside dimensions (holes)
acc. to DIN 7157, DIN ISO 286 Part 2**

		Tolerance zones shown for nominal dimension 60 mm																	
		μm																	
		+500																	
		+400																	
		+300																	
		+200																	
		+100																	
		0																	
		-100																	
		-200																	
		-300																	
		-400																	
		-500																	
ISO abbrev.	Series 1 Series 2	P7	N7	N9	M7	K7	J6	J7	H7	H8	H11	G7	F8	E9	D9	D10	C11	A11	
Nominal dimensions in mm	from to 1 3	-6 -16	-4 -14	-4 -29	-2 -12	0 -10	+2 -4	+4 -6	+10 0	+14 0	+60 0	+12 +2	+20 +6	+39 +14	+45 +20	+60 +20	+120 +60	+330 +270	
	above to 3 6	-8 -20	-4 -16	0 -30	0 -12	+3 -9	+5 -3	+6 -6	+12 0	+18 0	+75 0	+16 +4	+28 +10	+50 +20	+60 +30	+78 +30	+145 +70	+345 +270	
	above to 6 10	-9 -24	-4 -19	0 -36	0 -15	+5 -10	+5 -4	+8 -7	+15 0	+22 0	+90 0	+20 +5	+35 +13	+61 +25	+76 +40	+98 +40	+170 +80	+370 +280	
	above to 10 14	-11 -29	-5 -23	0 -43	0 -18	+6 -12	+6 -5	+10 -8	+18 0	+27 0	+110 0	+24 +6	+43 +16	+75 +32	+93 +50	+120 +50	+205 +95	+400 +290	
	above to 14 18	-14 -35	-7 -28	0 -52	0 -21	+6 -15	+8 -5	+12 -9	+21 0	+33 0	+130 0	+28 +7	+53 +20	+92 +40	+117 +65	+149 +65	+240 +110	+430 +300	
	above to 18 24	-17 -42	-8 -33	0 -62	0 -25	+7 -18	+10 -6	+14 -11	+25 0	+39 0	+160 0	+34 +9	+64 +25	+112 +50	+142 +80	+180 +80	+280 +130	+470 +310	
	above to 24 30	-21 -51	-9 -39	0 -74	0 -30	+9 -21	+13 -6	+18 -12	+30 0	+46 0	+190 0	+40 +10	+76 +30	+134 +60	+174 +100	+220 +100	+330 +150	+530 +360	
	above to 30 40	-24 -59	-10 -45	0 -87	0 -35	+10 -25	+16 -6	+22 -13	+35 0	+54 0	+220 0	+47 +12	+90 +36	+159 +72	+207 +120	+260 +120	+390 +180	+600 +410	
	above to 40 50	-28 -68	-12 -52	0 -100	0 -40	+12 -28	+18 -7	+26 -14	+40 0	+63 0	+250 0	+54 +14	+106 +43	+185 +85	+245 +145	+305 +145	+460 +210	+800 +520	
	above to 50 65	-33 -79	-14 -60	0 -115	0 -46	+13 -33	+22 -7	+30 -16	+46 0	+72 0	+290 0	+61 +15	+122 +50	+215 +100	+285 +170	+355 +170	+550 +260	+950 +740	
	above to 65 80	-36 -88	-14 -66	0 -130	0 -52	+16 -36	+25 -7	+36 -16	+52 0	+81 0	+320 0	+69 +17	+137 +56	+240 +110	+320 +190	+400 +190	+620 +330	+1240 +1050	
	above to 80 100	-41 -98	-16 -73	0 -140	0 -57	+17 -40	+29 -7	+39 -18	+57 0	+89 0	+360 0	+75 +18	+151 +62	+265 +125	+350 +210	+440 +210	+720 +400	+1560 +1350	
	above to 100 120	-45 -108	-17 -80	0 -155	0 -63	+18 -45	+33 -7	+43 -20	+63 0	+97 0	+400 0	+83 +20	+165 +68	+290 +135	+385 +230	+480 +230	+840 +440	+1900 +1500	
	above to 120 140	-45 -108	-17 -80	0 -155	0 -63	+18 -45	+33 -7	+43 -20	+63 0	+97 0	+400 0	+83 +20	+165 +68	+290 +135	+385 +230	+480 +230	+840 +440	+1900 +1500	
	above to 140 160	-45 -108	-17 -80	0 -155	0 -63	+18 -45	+33 -7	+43 -20	+63 0	+97 0	+400 0	+83 +20	+165 +68	+290 +135	+385 +230	+480 +230	+840 +440	+1900 +1500	
	above to 160 180	-45 -108	-17 -80	0 -155	0 -63	+18 -45	+33 -7	+43 -20	+63 0	+97 0	+400 0	+83 +20	+165 +68	+290 +135	+385 +230	+480 +230	+840 +440	+1900 +1500	
	above to 180 200	-45 -108	-17 -80	0 -155	0 -63	+18 -45	+33 -7	+43 -20	+63 0	+97 0	+400 0	+83 +20	+165 +68	+290 +135	+385 +230	+480 +230	+840 +440	+1900 +1500	
	above to 200 225	-45 -108	-17 -80	0 -155	0 -63	+18 -45	+33 -7	+43 -20	+63 0	+97 0	+400 0	+83 +20	+165 +68	+290 +135	+385 +230	+480 +230	+840 +440	+1900 +1500	
	above to 225 250	-45 -108	-17 -80	0 -155	0 -63	+18 -45	+33 -7	+43 -20	+63 0	+97 0	+400 0	+83 +20	+165 +68	+290 +135	+385 +230	+480 +230	+840 +440	+1900 +1500	
	above to 250 280	-45 -108	-17 -80	0 -155	0 -63	+18 -45	+33 -7	+43 -20	+63 0	+97 0	+400 0	+83 +20	+165 +68	+290 +135	+385 +230	+480 +230	+840 +440	+1900 +1500	
	above to 280 315	-45 -108	-17 -80	0 -155	0 -63	+18 -45	+33 -7	+43 -20	+63 0	+97 0	+400 0	+83 +20	+165 +68	+290 +135	+385 +230	+480 +230	+840 +440	+1900 +1500	
	above to 315 355	-45 -108	-17 -80	0 -155	0 -63	+18 -45	+33 -7	+43 -20	+63 0	+97 0	+400 0	+83 +20	+165 +68	+290 +135	+385 +230	+480 +230	+840 +440	+1900 +1500	
	above to 355 400	-45 -108	-17 -80	0 -155	0 -63	+18 -45	+33 -7	+43 -20	+63 0	+97 0	+400 0	+83 +20	+165 +68	+290 +135	+385 +230	+480 +230	+840 +440	+1900 +1500	
	above to 400 450	-45 -108	-17 -80	0 -155	0 -63	+18 -45	+33 -7	+43 -20	+63 0	+97 0	+400 0	+83 +20	+165 +68	+290 +135	+385 +230	+480 +230	+840 +440	+1900 +1500	
	above to 450 500	-45 -108	-17 -80	0 -155	0 -63	+18 -45	+33 -7	+43 -20	+63 0	+97 0	+400 0	+83 +20	+165 +68	+290 +135	+385 +230	+480 +230	+840 +440	+1900 +1500	
	ISO abbrev.	Series 1 Series 2	P7	N7	N9	M7	K7	J6	J7	H7	H8	H11	G7	F8	E9	D9	D10	C11	A11

Standardization

ISO Tolerance Zones, Allowances, Fit Tolerances Outside Dimensions (Shafts)

ISO tolerance zones, allowances, fit tolerances; Outside dimensions (shafts) acc. to DIN 7157, DIN ISO 286 Part 2																									
μm	Tolerance zones shown for nominal dimension 60 mm																								
	ISO abbrev.	Series 1 Series 2	x8/u8 1)	s6	r5	r6	n6	m5	m6	k5	k6	j6	js6	h6	h7	h8	h9	h11	g6	f7	e8	d9	c11	a11	
+500																									
+400																									
+300																									
+200																									
+100																									
0																									
-100																									
-200																									
-300																									
-400																									
-500																									
Nominal dimensions in mm	from to	1 3	+34 +20	+20 +14	+14 +10	+16 +10	+10 +6	+6 +8	+8 +4	+4 +6	+6 +4	+4 +3	+3 0	0 0	0 0	0 0	0 0	0 0	-2 -6	-6 -14	-14 -20	-20 -28	-28 -30	-30 -60	-60 -270
	above to	3 6	+46 +28	+27 +19	+20 +15	+23 +15	+16 +8	+9 +4	+12 +4	+6 +1	+9 +1	+6 +2	+4 -2	0 -8	0 -12	0 -18	0 -30	0 -75	0 -12	-4 -10	-10 -20	-20 -30	-30 -60	-60 -145	-145 -370
	above to	6 10	+56 +34	+25 +23	+28 +19	+19 +10	+12 +6	+15 +6	+7 +6	+10 +1	+7 +1	+4.5 -2	0 -4.5	0 -9	0 -15	0 -22	0 -36	0 -90	0 -14	-5 -28	-5 -40	-10 -40	-15 -80	-20 -170	-25 -370
	above to	10 14	+67 +40	+39 +28	+31 +23	+34 +23	+23 +12	+15 +7	+18 +7	+9 +1	+12 +1	+8 -3	+5.5 -5.5	0 -11	0 -18	0 -27	0 -43	0 -110	0 -17	-6 -34	-6 -59	-12 -93	-18 -205	-24 -400	-30 -490
	above to	14 18	+72 +45	+28 +23	+23 +23	+23 +12	+12 +7	+12 +7	+11 +7	+11 +1	+15 +1	+9 -4	+6.5 -6.5	0 -13	0 -21	0 -33	0 -52	0 -130	0 -20	-7 -41	-7 -73	-14 -117	-20 -240	-26 -430	-32 -490
	above to	18 24	+87 +54	+48 +35	+37 +28	+41 +28	+28 +15	+17 +8	+21 +8	+11 +2	+15 +2	+9 -4	+6.5 -6.5	0 -13	0 -21	0 -33	0 -52	0 -130	0 -20	-7 -41	-7 -73	-14 -117	-20 -240	-26 -430	-32 -490
	above to	24 30	+81 +48	+35 +28	+28 +28	+28 +15	+15 +8	+15 +8	+13 +8	+18 +2	+11 +2	+11 -5	+8 -8	0 -16	0 -25	0 -39	0 -62	0 -160	0 -25	-9 -50	-9 -89	-18 -142	-24 -290	-30 -480	-36 -490
	above to	30 40	+99 +60	+59 +43	+45 +34	+50 +34	+33 +17	+20 +9	+25 +9	+13 +2	+18 +2	+11 -5	+8 -8	0 -16	0 -25	0 -39	0 -62	0 -160	0 -25	-9 -50	-9 -89	-18 -142	-24 -290	-30 -480	-36 -490
	above to	40 50	+109 +70	+43 +34	+34 +34	+34 +17	+17 +9	+17 +9	+13 +2	+18 +2	+11 -5	+8 -8	0 -16	0 -25	0 -39	0 -62	0 -160	0 -25	-9 -50	-9 -89	-18 -142	-24 -290	-30 -480	-36 -490	-42 -490
	above to	50 65	+133 +87	+72 +53	+54 +41	+60 +41	+39 +24	+24 +30	+15 +15	+21 +2	+21 +2	+12 -7	+9.5 -9.5	0 -19	0 -30	0 -46	0 -74	0 -190	0 -29	-10 -60	-10 -106	-20 -174	-26 -330	-32 -530	-38 -530
	above to	65 80	+148 +102	+78 +59	+56 +43	+62 +43	+20 +11	+11 +11	+11 +2	+11 +2	+2 +2	-7	-9.5	-19	-30	-46	-74	-190	-29	-60	-106	-174	-340	-550	-610
	above to	80 100	+178 +124	+93 +71	+66 +51	+73 +51	+45 +28	+28 +35	+18 +18	+25 +3	+13 +3	+13 -9	+11 -11	-22	-35	-54	-87	-220	-34	-71	-126	-207	-390	-600	
	above to	100 120	+198 +144	+101 +79	+69 +54	+76 +54	+23 +13	+13 +13	+13 +3	+13 +3	+3 +3	-9	-11	-22	-35	-54	-87	-220	-34	-71	-126	-207	-400	-630	
	above to	120 140	+233 +170	+117 +92	+81 +63	+88 +63	+52 +33	+33 +40	+21 +21	+28 +28	+14 +14	+12.5 -11	+12.5 -12.5	0 -25	0 -40	0 -63	0 -100	0 -250	0 -39	-14 -83	-14 -148	-28 -245	-34 -460	-40 -770	
	above to	140 160	+253 +190	+125 +100	+83 +65	+90 +65	+52 +27	+33 +15	+40 +15	+21 +3	+28 +3	+14 -11	+12.5 -12.5	0 -25	0 -40	0 -63	0 -100	0 -250	0 -39	-14 -83	-14 -148	-28 -245	-34 -460	-40 -770	
	above to	160 180	+273 +210	+133 +108	+86 +68	+93 +68																			
	above to	180 200	+308 +236	+151 +122	+97 +77	+106 +77																			
	above to	200 225	+330 +258	+159 +130	+100 +80	+109 +80	+60 +31	+37 +17	+46 +17	+24 +4	+33 +4	+16 -13	+14.5 -14.5	0 -29	0 -46	0 -72	0 -115	0 -290	0 -44	-15 -96	-15 -172	-30 -285	-40 -480	-50 -1030	
	above to	225 250	+356 +284	+169 +140	+104 +84	+113 +84																			
	above to	250 280	+396 +315	+190 +158	+117 +94	+126 +94																			
	above to	280 315	+431 +350	+202 +170	+121 +98	+130 +98	+34 +20	+20 +20	+4 +4	+4 +4	+4 -16	-16	-16	-32	-52	-81	-130	-320	-49	-108	-191	-320	-480	-1050	
	above to	315 355	+479 +390	+226 +190	+133 +108	+144 +108	+73 +37	+46 +21	+57 +21	+29 +4	+40 +4	+18 -18	+18 -18	0 -36	0 -57	0 -89	0 -140	0 -360	0 -54	-18 -119	-18 -214	-36 -350	-48 -400	-60 -1710	
	above to	355 400	+524 +435	+244 +208	+139 +114	+150 +114	+37 +21	+21 +21	+4 +4	+4 +4	+4 -18	-18	-18	-36	-57	-89	-140	-360	-54	-119	-214	-350	-540	-1350	
	above to	400 450	+587 +490	+272 +232	+153 +126	+166 +126	+80 +50	+63 +50	+32 +32	+45 +45	+20 +20	+20 -20	+20 -20	0 -40	0 -63	0 -97	0 -155	0 -400	0 -60	-20 -131	-20 -232	-40 -385	-50 -480	-60 -2050	
	above to	450 500	+637 +540	+292 +252	+159 +132	+172 +132	+40 +23	+23 +23	+5 +5	+5 +5	+5 -20	-20	-20	-40	-63	-97	-155	-400	-60	-131	-232	-385	-540	-1650	

1) Up to nominal dimension 24 mm: x8; above nominal dimension 24 mm: u8

Standardization

Parallel Keys, Taper Keys, and Centre Holes

2

Dimensions of parallel keys and taper keys																								
Diameter		Width	Height	Depth of keyway in shaft	Depth of keyway in hub		Lengths, see below																	
d		b	h	t ₁	t ₂		l ₁		l															
above to		1)	2)		DIN		DIN																	
mm		mm	mm	mm	6885/1	6886/6887 2)	6885/1	6886																
					mm	mm	from mm	to mm	from mm	to mm														
6	8	2	2	1.2	1.0	0.5	6	20	6	20														
8	10	3	3	1.8	1.4	0.9	6	36	8	36														
10	12	4	4	2.5	1.8	1.2	8	45	10	45														
12	17	5	5	3	2.3	1.7	10	56	12	56														
17	22	6	6	3.5	2.8	2.2	14	70	16	70														
22	30	8	7	4	3.3	2.4	18	90	20	90														
30	38	10	8	5	3.3	2.4	22	110	25	110														
38	44	12	8	5	3.3	2.4	28	140	32	140														
44	50	14	9	5.5	3.8	2.9	36	160	40	160														
50	58	16	10	6	4.3	3.4	45	180	45	180														
58	65	18	11	7	4.4	3.4	50	200	50	200														
65	75	20	12	7.5	4.9	3.9	56	220	56	220														
75	85	22	14	9	5.4	4.4	63	250	63	250														
85	95	25	14	9	5.4	4.4	70	280	70	280														
95	110	28	16	10	6.4	5.4	80	320	80	320														
110	130	32	18	11	7.4	6.4	90	360	90	360														
130	150	36	20	12	8.4	7.1	100	400	100	400														
150	170	40	22	13	9.4	8.1	110	400	110	400														
170	200	45	25	15	10.4	9.1	125	400	125	400														
200	230	50	28	17	11.4	10.1	140	400	140	400														
230	260	56	32	20	12.4	11.1	160	400	160	400														
260	290	63	32	20	12.4	11.1	180	400	180	400														
290	330	70	36	22	14.4	13.1	200	400	200	400														
330	380	80	40	25	15.4	14.1	220	400	220	400														
380	440	90	45	28	17.4	16.1	250	400	250	400														
440	500	100	50	31	19.5	18.1	280	400	280	400														
Lengths mm l ₁ or l				6	8	10	12	14	16	18	20	22	25	28	32	36	40	45	50	56	63	70	80	
				90	100	110	125	140	160	180	200	220	250	280	320	360	400							

Parallel keys and taper keys
acc. to DIN 6885 Part 1, 6886 and 6887

Side fitting square and rectangular keys

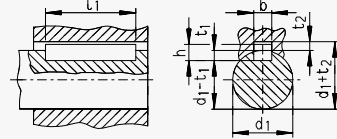

Parallel key and keyway acc. to DIN 6885 Part 1

Square and rectangular taper keys

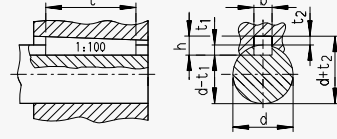

Taper and round-ended sunk key and keyway acc. to DIN 6886

- 1) The tolerance zone for hub keyway width b for parallel keys with normal fit is ISO JS9 and with close fit ISO P9. The tolerance zone for shaft keyway width b with normal fit is ISO N9 and with close fit ISO P9.
- 2) Dimension h of the taper key names the largest height of the key, and dimension t₂ the largest depth of the hub keyway. The shaft keyway and hub keyway dimensions according to DIN 6887 - taper keys with gib head - are equal to those of DIN 6886.

Dimensions of 60° centre holes in mm								Centre holes in shaft ends (centerings) acc. to DIN 332 Part 1	
Recommended diameters d ²⁾		Bore diameter d ₁	Form B				Minimum dimensions t		
above	to		a ¹⁾	b	d ₂	d ₃			
6	10	1.6	5.5	0.5	3.35	5	3.4		
10	25	2	6.6	0.6	4.25	6.3	4.3		
		2.5	8.3	0.8	5.3	8	5.4		
		3.15	10	0.9	6.7	10	6.8		
		4	12.7	1.2	8.5	12.5	8.6		
25	63	5	15.6	1.6	10.6	16	10.8		
63	100	6.3	20	1.4	13.2	18	12.9		

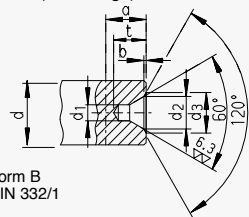

Form B
DIN 332/1

Recommended diameters d ₆ ²⁾		Form DS									
above	to	d ₁	d ₂ ³⁾	d ₃	d ₄	d ₅	t ₁ ⁺²	t ₂ ^{min.}	t ₃ ⁺¹	t ₄ [≈]	t ₅ [≈]
7	10	M3	2.5	3.2	5.3	5.8	9	12	2.6	1.8	0.2
10	13	M4	3.3	4.3	6.7	7.4	10	14	3.2	2.1	0.3
13	16	M5	4.2	5.3	8.1	8.8	12.5	17	4	2.4	0.3
16	21	M6	5	6.4	9.6	10.5	16	21	5	2.8	0.4
21	24	M8	6.8	8.4	12.2	13.2	19	25	6	3.3	0.4
24	30	M10	8.5	10.5	14.9	16.3	22	30	7.5	3.8	0.6
30	38	M12	10.2	13	18.1	19.8	28	37	9.5	4.4	0.7
38	50	M16	14	17	23	25.3	36	45	12	5.2	1.0
50	85	M20	17.5	21	28.4	31.3	42	53	15	6.4	1.3
85	130	M24	21	25	34.2	38	50	63	18	8	1.6
130	225	M30*	26	31	44	48	60	77	17	11	1.9
225	320	M36*	31.5	37	55	60	74	93	22	15	2.3
320	500	M42*	37	43	65	71	84	105	26	19	2.7

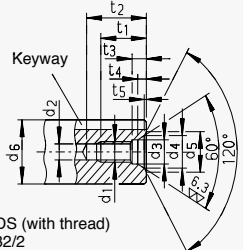

Form DS (with thread)
DIN 332/2

- 1) Cutting-off dimension in case of no centering
- 2) Diameter applies to finished workpiece
- * Dimensions not acc. to DIN 332 Part 2
- 3) Drill diameter for tapping-size holes acc. to DIN 336 Part 1

Table of Contents Section 3

Physics	Page
Internationally Determined Prefixes	32
Basic SI Units	32
Derived SI Units Having Special Names and Special Unit Symbols	33
Legal Units Outside the SI	33
Physical Quantities and Units of Lengths and Their Powers	34
Physical Quantities and Units of Time	35
Physical Quantities and Units of Mechanics	35 – 37
Physical Quantities and Units of Thermodynamics and Heat Transfer	37 + 38
Physical Quantities and Units of Electrical Engineering	38
Physical Quantities and Units of Lighting Engineering	39
Different Measuring Units of Temperature	39
Measures of Length	40
Square Measures	40
Cubic Measures	41
Weights	41
Energy, Work, Quantity of Heat	41
Power, Energy Flow, Heat Flow	42
Pressure and Tension	42
Velocity	42
Equations for Linear Motion and Rotary Motion	43

Physics

Internationally Determined Prefixes

Basic SI Units

3

Internationally determined prefixes					
Decimal multiples and sub-multiples of units are represented with prefixes and symbols. Prefixes and symbols are used only in combination with unit names and unit symbols.					
Factor by which the unit is multiplied	Prefix	Symbol	Factor by which the unit is multiplied	Prefix	Symbol
10^{-18}	Atto	a	10^1	Deka	da
10^{-15}	Femto	f	10^2	Hecto	h
10^{-12}	Pico	p	10^3	Kilo	k
10^{-9}	Nano	n	10^6	Mega	M
10^{-6}	Micro	μ	10^9	Giga	G
10^{-3}	Milli	m	10^{12}	Tera	T
10^{-2}	Centi	c	10^{15}	Peta	P
10^{-1}	Deci	d	10^{18}	Exa	E

– Prefix symbols and unit symbols are written without blanks and together they form the symbol for a new unit. An exponent on the unit symbol also applies to the prefix symbol.

Example:

$1 \text{ cm}^3 = 1 \cdot (10^{-2}\text{m})^3 = 1 \cdot 10^{-6}\text{m}^3$
 $1 \mu\text{s} = 1 \cdot 10^{-6}\text{s}$
 $10^6\text{s}^{-1} = 10^6\text{Hz} = 1 \text{ MHz}$

– When giving sizes by using prefix symbols and unit symbols, the prefixes should be chosen in such a way that the numerical values are between 0.1 and 1000.

Example:

12 kN instead of $1.2 \cdot 10^4\text{N}$
 3.94 mm instead of 0.00394 m
 1.401 kPa instead of 1401 Pa
 31 ns instead of $3.1 \cdot 10^{-8}\text{s}$

– Prefixes are not used with the basic SI unit kilo-gram (kg) but with the unit gram (g).

Example:

Milligram (mg), NOT microkilogram (μkg).

– Combinations of prefixes and the following units are not allowed:

- Units of angularity:** degree, minute, second
- Units of time:** minute, hour, year, day
- Unit of temperature:** degree Celsius

Basic SI units					
Physical quantity	Basic SI unit		Physical quantity	Basic SI unit	
	Name	Symbol		Name	Symbol
Length	Metre	m	Thermodynamic temperature	Kelvin	K
Mass	Kilogram	kg			
Time	Second	s	Amount of substance	Mol	mol
Electric current	Ampere	A	Luminous intensity	Candela	cd

Physics

Derived SI Units

Legal Units Outside the SI

Derived SI units having special names and special unit symbols			
Physical quantity	SI unit		Relation
	Name		
Plane angle	Radian	rad	$1 \text{ rad} = 1 \text{ m/m}$
Solid angle	Steradian	sr	$1 \text{ sr} = 1 \text{ m}^2/\text{m}^2$
Frequency, cycles per second	Hertz	Hz	$1 \text{ Hz} = 1 \text{ s}^{-1}$
Force	Newton	N	$1 \text{ N} = 1 \text{ kg} \cdot \text{m}/\text{s}^2$
Pressure, mechanical stress	Pascal	Pa	$1 \text{ Pa} = 1 \text{ N}/\text{m}^2 = 1 \text{ kg}/(\text{m} \cdot \text{s}^2)$
Energy; work; quantity of heat	Joule	J	$1 \text{ J} = 1 \text{ N} \cdot \text{m} = 1 \text{ W} \cdot \text{s} = 1 \text{ kg} \cdot \text{m}^2/\text{s}^2$
Power, heat flow	Watt	W	$1 \text{ W} = 1 \text{ J}/\text{s} = 1 \text{ kg} \cdot \text{m}^2/\text{s}^3$
Electric charge	Coulomb	C	$1 \text{ C} = 1 \text{ A} \cdot \text{s}$
Electric potential	Volt	V	$1 \text{ V} = 1 \text{ J}/\text{C} = 1 (\text{kg} \cdot \text{m}^2)/(\text{A} \cdot \text{s}^3)$
Electric capacitance	Farad	F	$1 \text{ F} = 1 \text{ C}/\text{V} = 1 (\text{A}^2 \cdot \text{s}^4)/(\text{kg} \cdot \text{m}^2)$
Electric resistance	Ohm	Ω	$1 \Omega = 1 \text{ V}/\text{A} = 1 (\text{kg} \cdot \text{m}^2)/\text{A}^2 \cdot \text{s}^3$
Electric conductance	Siemens	S	$1 \text{ S} = 1 \Omega^{-1} = 1 (\text{A}^2 \cdot \text{s}^3)/(\text{kg} \cdot \text{m}^2)$
Celsius temperature	degrees Celsius	$^{\circ}\text{C}$	$0^{\circ}\text{C} = 273.15 \text{ K}$ $\Delta 1^{\circ}\text{C} = \Delta 1 \text{ K}$
Inductance	Henry	H	$1 \text{ H} = 1 \text{ V} \cdot \text{s}/\text{A}$

Legal units outside the SI			
Physical quantity	Unit name	Unit symbol	Definition
Plane angle	Round angle	1)	$1 \text{ perigon} = 2 \pi \text{ rad}$
	Gon	gon	$1 \text{ gon} = (\pi/200) \text{ rad}$
	Degree	$^{\circ}$ 2)	$1^{\circ} = (\pi/180) \text{ rad}$
	Minute	' 2)	$1' = (1/60)^{\circ}$
	Second	" 2)	$1'' = (1/60)'$
Volume	Litre	l	$1 \text{ l} = 1 \text{ dm}^3 = (1/1000) \text{ m}^3$
Time	Minute	min 2)	$1 \text{ min} = 60 \text{ s}$
	Hour	h 2)	$1 \text{ h} = 60 \text{ min} = 3600 \text{ s}$
	Day	d 2)	$1 \text{ d} = 24 \text{ h} = 86400 \text{ s}$
	Year	a 2)	$1 \text{ a} = 365 \text{ d} = 8760 \text{ h}$
Mass	Ton	t	$1 \text{ t} = 10^3 \text{ kg} = 1 \text{ Mg}$
Pressure	Bar	bar	$1 \text{ bar} = 10^5 \text{ Pa}$

1) A symbol for the round angle has not been internationally determined

2) Do not use with prefixes

Physics

Physical Quantities and Units of Lengths and Their Powers

3

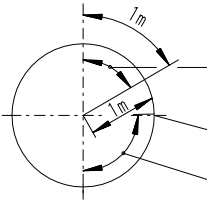
Physical quantities and units of lengths and their powers			
Symbol	Physical quantity	SI unit Symbol Name	N.: Note L.U.: Further legal units N.A.: Units no longer allowed
l	Length	m (metre)	N.: Basic unit L.U.: μm ; mm; cm; dm; km; etc. N.A.: micron (μ): $1 \mu = 1 \mu\text{m}$ Ångström (Å): $1 \text{Å} = 10^{-10} \text{m}$
A	Area	m^2 (square metre)	L.U.: mm^2 ; cm^2 ; dm^2 ; km^2 are (a): $1 \text{a} = 10^2 \text{m}^2$ hectare (ha): $1 \text{ha} = 10^4 \text{m}^2$
V	Volume	m^3 (cubic metre)	L.U.: mm^3 ; cm^3 ; dm^3 litre (l): $1 \text{l} = 1 \text{dm}^3$
H	Moment of area	m^3	N.: moment of a force; moment of resistance L.U.: mm^3 ; cm^3
I	Second moment of area	m^4	N.: formerly: geometrical moment of inertia L.U.: mm^4 ; cm^4
α β γ	Plane angle	rad (radian)	<p>N.: $1 \text{ rad} = \frac{1 \text{ m (arc)}}{1 \text{ m (radius)}} = \frac{1 \text{ m}}{1 \text{ m}} = 1 \text{ m/m}$</p>  <p>L.U. : μrad, mrad</p> <p>Degree ($^\circ$) : $1^\circ = \frac{\pi}{180} \text{ rad}$</p> <p>Minute ($'$) : $1' = \frac{1^\circ}{60}$</p> <p>Second ($''$) : $1'' = \frac{1'}{60}$</p> <p>Gon (gon) : $1 \text{ gon} = \frac{\pi}{200} \text{ rad}$</p> <p>N.A. : Right angle (L) : $1 \text{L} = \frac{\pi}{2} \text{ rad}$</p> <p>Centesimal degree (g) : $1 \text{g} = 1 \text{ gon}$</p> <p>Centesimal minute (c) : $1^c = \frac{1}{100} \text{ gon}$</p> <p>Centesimal second (cc) : $1^{cc} = \frac{1^c}{100}$</p>
Ω ω	Solid angle	sr (steradian)	N.: $1 \text{ sr} = \frac{1 \text{ m}^2 \text{ (spherical surface)}}{1 \text{ m}^2 \text{ (square of spherical radius)}} = 1 \frac{\text{m}^2}{\text{m}^2}$

Physics

Physical Quantities and Units of Time and of Mechanics

Physical quantities and units of time			
Symbol	Physical quantity	SI unit Symbol Name	N.: Note L.U.: Further legal units N.A.: Units no longer allowed
t	Time, Period, Duration	s (second)	N.: Basic unit L.U.: ns; μ s; ms; ks Minute (min): 1 min = 60 s Hour (h): 1 h = 60 min Day (d): 1 d = 24 h Year (a): 1 a = 365 d (Do not use prefixes for decimal multiples and sub-multiples of min; h; d; a)
f	Frequency, Periodic frequency	Hz (Hertz)	L.U.: kHz; MHz; GHz; THz Hertz (Hz): 1 Hz = 1/s
n	Rotational frequency (speed)	s^{-1}	N.: Reciprocal value of the duration of one revolution L.U.: $\text{min}^{-1} = 1/\text{min}$
v	Velocity	m/s	L.U.: cm/s; m/h; km/s; km/h $1 \text{ km/h} = \frac{1}{3.6} \text{ m/s}$
a	Acceleration, linear	m/s^2	N.: Time-related velocity L.U.: cm/s^2
g	Gravity	m/s^2	N.: Gravity varies locally. Normal gravity (g_n): $g_n = 9.80665 \text{ m/s}^2 \approx 9.81 \text{ m/s}^2$
ω	Angular velocity	rad/s	L.U.: rad/min
α	Angular acceleration	rad/s^2	L.U.: $^\circ/\text{s}^2$
\dot{V}	Volume flow rate	m^3/s	L.U.: l/s; l/min; dm^3/s ; l/h; m^3/h ; etc.

Physical quantities and units of mechanics			
Symbol	Physical quantity	SI unit Symbol Name	N.: Note L.U.: Further legal units N.A.: Units no longer allowed
m	Mass	kg (kilogram)	N.: Basic unit L.U.: μ g; mg; g; Mg ton (t): 1 t = 1000 kg
m'	Mass per unit length	kg/m	N.: $m' = m/l$ L.U.: mg/m; g/km In the textile industry: Tex (tex): 1 tex = $10^{-6} \text{ kg/m} = 1 \text{ g/km}$
m''	Mass in relation to the surface	kg/m^2	N.: $m'' = m/A$ L.U.: g/mm^2 ; g/m^2 ; t/m^2

Physics

Physical Quantities and Units of Mechanics

3

Physical quantities and units of mechanics (continued)			
Symbol	Physical quantity	SI unit Symbol Name	N.: Note L.U.: Further legal units N.A.: Units no longer allowed
ρ	Density	kg/m ³	N.: $\rho = m/V$ L.U.: g/cm ³ ; kg/dm ³ ; Mg/m ³ ; t/m ³ ; kg/l 1g/cm ³ = 1 kg/dm ³ = 1 Mg/m ³ = 1 t/m ³ = 1 kg/l
J	Mass moment of inertia; second mass moment	kg · m ²	N.: Instead of the former flywheel effect GD ² GD ² in kpm ² now : $J = \frac{GD^2}{4}$ L.U.: g · m ² ; t · m ²
m	Rate of mass flow	kg/s	L.U.: kg/h; t/h
F	Force	N (Newton)	L.U.: μ N; mN; kN; MN; etc.; 1 N = 1 kg m/s ² N.A.: kp (1 kp = 9.80665 N)
G	Weight	N (Newton)	N.: Weight = mass acceleration due to gravity L.U.: kN; MN; GN; etc.
M, T	Torque	Nm	L.U.: μ Nm; mNm; kNm; MNm; etc. N.A.: kpm; pcm; pmm; etc.
M _b	Bending moment	Nm	L.U.: Nmm; Ncm; kNm; etc. N.A.: kpm; kpcm; kpm; etc.
p	Pressure	Pa (Pascal)	N.: 1 Pa = 1 N/m ² L.U.: Bar (bar): 1 bar = 100000 Pa = 10 ⁵ Pa μ bar; mbar N.A.: kp/cm ² ; at; ata; atü; mmWS; mmHg; Torr 1kp/cm ² = 1 at = 0.980665 bar 1 atm = 101325 Pa = 1.01325 bar 1 Torr = $\frac{101325}{760}$ Pa = 133.322 Pa 1 mWS = 9806.65 Pa = 9806.65 N/m ² 1 mmHg = 133.322 Pa = 133.322 N/m ²
P _{abs}	Absolute pressure	Pa (Pascal)	
P _{amb}	Ambient atmospheric pressure	Pa (Pascal)	
P _e	Pressure above atmospheric	Pa (Pascal)	$P_e = P_{abs} - P_{amb}$
σ	Direct stress (tensile and compressive stress)	N/m ²	L.U.: N/mm ² 1 N/mm ² = 10 ⁶ N/m ² = 1 MPa
τ	Shearing stress	N/m ²	L.U.: N/mm ²
ε	Extension	m/m	N.: $\Delta l / l$ L.U.: μ m/m; cm/m; mm/m

Physics

Physical Quantities and Units of Mechanics, Thermodynamics and Heat Transfer

Physical quantities and units of mechanics (continued)			
Symbol	Physical quantity	SI unit Symbol Name	N.: Note L.U.: Further legal units N.A.: Units no longer allowed
W, A	Work	J (Joule)	N.: 1 J = 1 Nm = 1 Ws L.U.: mJ; kJ; MJ; GJ; TJ; kWh 1 kWh = 3.6 MJ
E, W	Energy		N.A.: kpm; cal; kcal 1 cal = 4.1868 J; 860 kcal = 1 kWh
P	Power	W (Watt)	N.: 1 W = 1 J/s = 1 Nm/s L.U.: μW; mW; kW; MW; etc. kJ/s; kJ/h; MJ/h; etc.
Q̇	Heat flow		N.A.: PS; kpm/s; kcal/h 1 PS = 735.49875 W 1 kpm/s = 9.81 W 1 kcal/h = 1.16 W 1 hp = 745.70 W
η	Dynamic viscosity	Pa · s	N.: 1 Pa · s = 1 Ns/m ² L.U.: dPa · s; mPa · s N.A.: Poise (P): 1 P = 0.1 Pa · s
ν	Kinematic viscosity	m ² /s	L.U.: mm ² /s; cm ² /s N.A.: Stokes (St): 1 St = 1/10000 m ² /s 1cSt = 1 mm ² /s

Physical quantities and units of thermodynamics and heat transfer			
Symbol	Physical quantity	SI unit Symbol Name	N.: Note L.U.: Further legal units N.A.: Units no longer allowed
T	Thermo- dynamic temperature	K (Kelvin)	N.: Basic unit 273.15 K = 0 °C 373.15 K = 100 °C L.U.: mK
t	Celsius temperature	°C	N.: The degrees Celsius (°C) is a special name for the degrees Kelvin (K) when stating Celsius temperatures. The temperature interval of 1 K equals that of 1 °C.
Q	Heat, Quantity of heat	J	1 J = 1 Nm = 1 Ws L.U.: mJ; kJ; MJ; GJ; TJ N.A.: cal; kcal
a	Temperature conductivity	m ² /s	$a = \frac{\lambda}{\varrho \cdot c_p}$ $\lambda [W/(m \cdot K)] = \text{thermal conductivity}$ $\varrho [kg/m^3] = \text{density of the body}$ $c_p [J/(kg \cdot K)] = \text{specific heat capacity at constant pressure}$

Physics

Physical Quantities and Units of Thermodynamics, Heat Transfer and Electrical Engineering

3

Physical quantities and units of thermodynamics and heat transfer (continued)			
Symbol	Physical quantity	SI unit Symbol Name	N.: Note L.U.: Further legal units N.A.: Units no longer allowed
H	Enthalpy (Heat content)	J	N.: Quantity of heat absorbed under certain conditions L.U.: kJ; MJ; etc. N.A.: cal; Mcal; etc.
s	Entropy	J/K	1 J/K = 1 Ws/K = 1 Nm/K L.U.: kJ/K N.A.: kcal/deg; kcal/°K
α_h	Heat transfer coefficient	W/(m ² · K)	L.U.: W/(cm ² · K); kJ/(m ² · h · K) N.A.: cal/(cm ² · s · grd) kcal/(m ² · h · grd) ≈ 4.2 kJ/(m ² · h · K)
c	Specific heat capacity	J/(K · kg)	1 J/(K · kg) = W · s/(kg · K) N.: Heat capacity referred to mass N.A.: cal/(g · grd); kcal/(kg · grd); etc.
α_l	Coefficient of linear thermal expansion	K ⁻¹	m/(m · K) = K ⁻¹ N.: Temperature unit/length unit ratio L.U.: μm/(m · K); cm/(m · K); mm/(m · K)
α_v γ	Coefficient of volumetric expansion	K ⁻¹	m ³ /(m ³ · K) = K ⁻¹ N.: Temperature unit/volume ratio N.A.: m ³ /(m ³ · deg)

Physical quantities and units of electrical engineering			
Symbol	Physical quantity	SI unit Symbol Name	N.: Note L.U.: Further legal units N.A.: Units no longer allowed
I	Current strength	A (Ampere)	N.: Basic unit L.U.: pA; nA; μA; mA; kA; etc.
Q	Electric charge; Quantity of electricity	C (Coulomb)	1 C = 1 A · s 1 Ah = 3600 As L.U.: pC; nC; μC; kC
U	Electric voltage	V (Volt)	1 V = 1 W/A = 1 J/(s · A) = 1 A · Ω = 1 N · m/(s · A) L.U.: μV; mV; kV; MV; etc.
R	Electric resistance	Ω (Ohm)	1 Ω = 1 V/A = 1 W/A ² 1 J/(s · A ²) = 1 N · m/(s · A ²) L.U.: μΩ; mΩ; kΩ; etc.
G	Electric conductance	S (Siemens)	N.: Reciprocal of electric resistance 1 S = 1 Ω ⁻¹ = 1/Ω; G = 1/R L.U.: μS; mS; kS
C	Electric capacitance	F (Farad)	1 F = 1 C/V = 1 A · s/V = 1 A ² · s/W = 1 A ² · s ² /J = 1 A ² · s ² /(N · m) L.U.: pF; μF; etc.

Physics

Physical Quantities and Units of Lighting Engineering, Different Measuring Units of Temperature

Physical quantities and units of lighting engineering			
Symbol	Physical quantity	SI unit Symbol Name	N.: Note L.U.: Further legal units N.A.: Units no longer allowed
I	Luminous intensity	cd (Candela)	N.: Basic unit 1 cd = 1 lm (lumen) / sr (Steradian) L.U.: mcd; kcd
L	Luminous density; Luminance	cd / m ²	L.U.: cd / cm ² ; mcd/m ² ; etc. N.A.: Apostilb (asb): 1 asb = $\frac{1}{\pi}$ cd/m ² Nit (nt): 1 nt = 1 cd/m ² Stilb (sb): 1 sb = 10 ⁴ cd/m ²
Φ	Luminous flux	lm (Lumen)	1 lm = 1 cd · sr L.U.: klm
E	Illuminance	lx (Lux)	1 lx = 1 lm/m ²

Different measuring units of temperature			
Kelvin K T _K	Degrees Celsius °C t _C	Degrees Fahrenheit °F t _F	Degrees Rankine °R T _R
$T_K = 273.15 + t_C$	$t_C = T_K - 273.15$	$t_F = \frac{9}{5} \cdot T_K - 459.67$	$T_R = \frac{9}{5} \cdot T_K$
$T_K = 255.38 + \frac{5}{9} \cdot t_F$	$t_C = \frac{5}{9} (t_F - 32)$	$t_F = 32 + \frac{9}{5} \cdot t_C$	$T_R = \frac{9}{5} (t_C + 273.15)$
$T_K = \frac{5}{9} \cdot T_R$	$t_C = \frac{5}{9} T_R - 273.15$	$t_F = T_R - 459.67$	$T_R = 459.67 + t_F$

Comparison of some temperatures			
0.00 + 255.37 + 273.15 + 273.16 ¹⁾ + 373.15	- 273.15 - 17.78 0.00 + 0.01 ¹⁾ + 100.00	- 459.67 0.00 + 32.00 + 32.02 + 212.00	0.00 + 459.67 + 491.67 + 491.69 + 671.67

1) The triple point of water is +0.01 °C. The triple point of pure water is the equilibrium point between pure ice, air-free water and water vapour (at 1013.25 hPa).

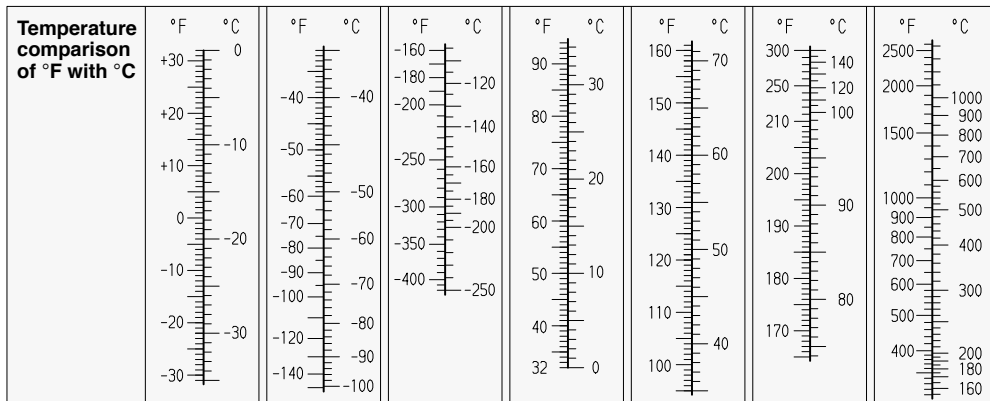

Physics

Measures of Length and Square Measures

3

Measures of length								
Unit	Inch in	Foot ft	Yard yd	Stat mile	Naut mile	mm	m	km
1 in =	1	0.08333	0.02778	–	–	25.4	0.0254	–
1 ft =	12	1	0.3333	–	–	304.8	0.3048	–
1 yd =	36	3	1	–	–	914.4	0.9144	–
1 stat mile =	63 360	5280	1760	1	0.8684	–	1609.3	1.609
1 naut mile =	72 960	6080	2027	1.152	1	–	1853.2	1.853
1 mm =	0.03937	$3.281 \cdot 10^{-3}$	$1.094 \cdot 10^{-3}$	–	–	1	0.001	10^{-6}
1 m =	39.37	3.281	1.094	–	–	1000	1	0.001
1 km =	39 370	3281	1094	0.6214	0.5396	10^6	1000	1

1 German statute mile = 7500 m 1 geograph. mile = 7420.4 m = 4 arc minutes at the equator (1° at the equator = 111.307 km)	Astronomical units of measure 1 light-second = 300 000 km 1 l.y. (light-year) = $9.46 \cdot 10^{12}$ km 1 parsec (parallax second, distances to the stars) = 3.26 l.y. 1 astronomical unit (mean distance of the earth from the sun) = $1.496 \cdot 10^8$ km Typographical unit of measure: 1 point (p) = 0.376 mm
1 internat. nautical mile } = 1852 m = 1 arc minute at the degree of longitude (1° at the meridian = 111.121 km) 1 German nautical mile (sm) 1 mille marin (French)	
Other measures of length of the Imperial system 1 micro-in = 10^{-6} in = 0.0254 μ m 1 mil = 1 thou = 0.001 in = 0.0254 mm 1 line = 0.1 in = 2.54 mm 1 fathom = 2 yd = 1.829 m 1 engineer's chain = 100 eng link = 100 ft = 30.48 m 1 rod = 1 perch = 1 pole = 25 surv link = 5.029 m 1 surveyor's chain = 100 surv link = 20.12 m 1 furlong = 1000 surv link = 201.2 m 1 stat league = 3 stat miles = 4.828 km	Other measures of length of the metric system <u>France:</u> 1 toise = 1.949 m 1 myriametre = 10 000 m <u>Russia:</u> 1 werschok = 44.45 mm 1 saschen = 2.1336 m 1 arschin = 0.7112 m 1 werst = 1.0668 km <u>Japan:</u> 1 shaku = 0.3030 m 1 ken = 1.818 m 1 ri = 3.927 km

Square measures										
Unit	sq in	sq ft	sq yd	sq mile	cm ²	dm ²	m ²	a	ha	km ²
1 square inch =	1	–	–	–	6.452	0.06452	–	–	–	–
1 square foot =	144	1	0.1111	–	929	9.29	0.0929	–	–	–
1 square yard =	1296	9	1	–	8361	83.61	0.8361	–	–	–
1 square mile =	–	–	–	1	–	–	–	–	259	2.59
1 cm ² =	0.155	–	–	–	1	0.01	–	–	–	–
1 dm ² =	15.5	0.1076	0.01196	–	100	1	0.01	–	–	–
1 m ² =	1550	10.76	1.196	–	10000	100	1	0.01	–	–
1 a =	–	1076	119.6	–	–	10000	100	1	0.01	–
1 ha =	–	–	–	–	–	–	10000	100	1	0.01
1 km ² =	–	–	–	0.3861	–	–	–	10000	100	1

Other square measures of the Imperial system 1 sq mil = $1 \cdot 10^{-6}$ sq in = 0.0006452 mm ² 1 sq line = 0.01 sq in = 6.452 mm ² 1 sq surveyor's link = 0.04047 m ₂ 1 sq rod = 1 sq perch = 1 sq pole = 625 sq surv link = 25.29 m ² 1 sq chain = 16 sq rod = 4.047 a 1 acre = 4 rod = 40.47 a 1 township (US) = 36 sq miles = 3.24 km ² 1 circular in = $\frac{\pi}{4}$ sq in = 5.067cm ² (circular area with 1 in dia.) 1 circular mil = $\frac{\pi}{4}$ sq mil = 0.0005067mm ² (circular area with 1 mil dia.)	Other square measures of the metric system <u>Russia:</u> 1 kwadr. archin = 0.5058 m ² 1 kwadr. saschen = 4.5522 m ² 1 dessjatine = 1.0925 ha 1 kwadr. werst = 1.138 km ² <u>Japan:</u> 1 tsubo = 3.306 m ² 1 se = 0.9917a 1 ho-ri = 15.42 km ²
--	--

Physics

Cubic Measures and Weights; Energy, Work, Quantity of Heat

Cubic measures									
Unit	cu in	cu ft	US liquid quart	US gallon	Imp quart	Imp gallon	cm ³	dm ³ (l)	m ³
1 cu in =	1	–	0.01732	–	0.01442	–	16.39	0.01639	–
1 cu ft =	1728	1	29.92	7.481	24.92	6.229	–	28.32	0.02832
1 cu yd =	46656	27	807.9	202	672.8	168.2	–	764.6	0.7646
1 US liquid quart =	57.75	0.03342	1	0.25	0.8326	0.2082	946.4	0.9464	–
1 US gallon =	231	0.1337	4	1	3.331	0.8326	3785	3.785	–
1 Imp quart =	69.36	0.04014	1.201	0.3002	1	0.25	1136	1.136	–
1 Imp gallon =	277.4	0.1605	4.804	1.201	4	1	4546	4.546	–
1 cm ³ =	0.06102	–	–	–	–	–	1	0.001	10 ⁶
1 dm ³ (l) =	61.02	0.03531	1.057	0.2642	0.88	0.22	1000	1	0.001
1 m ³ =	61023	35.31	1057	264.2	880	220	10 ⁶	1000	1
1 US minim = 0.0616 cm ³ (USA) 1 US fl dram = 60 minims = 3.696 cm ³ 1 US fl oz = 8 fl drams = 0.02957 l 1 US gill = 4 fl oz = 0.1183 l 1 US liquid pint = 4 gills = 0.4732 l 1 US liquid quart = 2 liquid pints = 0.9464 l 1 US gallon = 4 liquid quarts = 3.785 l 1 US dry pint = 0.5506 l 1 US dry quart = 2 dry pints = 1.101 l 1 US peck = 8 dry quarts = 8.811 l 1 US bushel = 4 pecks = 35.24 l 1 US liquid barrel = 31.5 gallons = 119.2 l 1 US barrel = 42 gallons = 158.8 l (for crude oil) 1 US cord = 128 cu ft = 3.625 m ³					1 Imp minim = 0.0592 cm ³ (GB) 1 Imp fl drachm = 60 minims = 3.552 cm ³ 1 Imp fl oz = 8 fl drachm = 0.02841 l 1 Imp gill = 5 fl oz = 0.142 l 1 Imp pint = 4 gills = 0.5682 l 1 Imp quart = 2 pints = 1.1365 l 1 Imp gallon = 4 quarts = 4.5461 l 1 Imp pottle = 2 quarts = 2.273 l 1 Imp peck = 4 pottles = 9.092 l 1 Imp bushel = 4 pecks = 36.37 l 1 Imp quarter = 8 bushels = 64 gallons = 290.94 l				

Weights										
Unit	dram	oz	lb	short cwt	long cwt	short ton	long ton	g	kg	t
1 dram =	1	0.0625	0.003906	–	–	–	–	1.772	0.00177	–
1 oz (ounce) =	16	1	0.0625	–	–	–	–	28.35	0.02835	–
1 lb (pound) =	256	16	1	0.01	0.008929	–	–	453.6	0.4536	–
1 short cwt (US) =	25600	1600	100	1	0.8929	0.05	0.04464	45359	45.36	0.04536
1 long cwt (GB/US) =	28672	1792	112	1.12	1	0.056	0.05	50802	50.8	0.0508
1 short ton (US) =	–	32000	2000	20	17.87	1	0.8929	–	907.2	0.9072
1 long ton (GB/US) =	–	35840	2240	22.4	20	1.12	1	–	1016	1.016
1g =	0.5643	0.03527	0.002205	–	–	–	–	1	0.001	10 ⁻⁶
1kg =	564.3	35.27	2.205	0.02205	0.01968	–	–	1000	1	0.001
1t =	–	35270	2205	22.05	19.68	1.102	0.9842	10 ⁶	1000	1
1 grain = 1 / 7000 lb = 0.0648 g 1 stone = 14 lb = 6.35 kg 1 short quarter = 1/4 short cwt = 11.34 kg 1 long quarter = 1/4 long cwt = 12.7 kg 1 quintal or 1 cental = 100 lb = 45.36 kg 1 quintal = 100 livres = 48.95 kg 1 kilopound = 1kp = 1000 lb = 453.6 kg			(GB) (GB) (USA) (GB / USA) (USA) (F) (USA)			1 solotnik = 96 dol = 4.2659 g 1 lot = 3 solotnik = 12.7978 g 1 funt = 32 lot = 0.409 kg 1 pud = 40 funt = 16.38 kg 1 berkowetz = 163.8 kg 1 kwan = 100 tael = 1000 momme = 10000 fun = 3.75 kg (J) 1 hyaku kin = 1 picul = 16 kwan = 60 kg (J)			(CIS) (CIS) (CIS) (CIS) (CIS) (J) (J)	
tdw = tons dead weight = lading capacity of a cargo vessel (cargo + ballast + fuel + stores), mostly given in long tons, i.e. 1 tdw = 1016 kg										

Energy, work, quantity of heat									
Work	ft lb	erg	J = Nm = Ws	kpm	PSH	hph	kWh	kcal	Btu
1 ft lb =	1	13.56 · 10 ⁶	1.356	0.1383	0.5121 · 10 ⁻⁶	0.505 · 10 ⁻⁶	0.3768 · 10 ⁻⁶	0.324 · 10 ⁻³	1.286 · 10 ⁻³
1 erg =	73.76 · 10 ⁻⁹	1	100 · 10 ⁻⁹	10.2 · 10 ⁻⁹	37.77 · 10 ⁻¹⁵	37.25 · 10 ⁻¹⁵	27.78 · 10 ⁻¹⁵	23.9 · 10 ⁻¹²	94.84 · 10 ⁻¹²
1 Joule (WS) =	0.7376	10 · 10 ⁶	1	0.102	377.7 · 10 ⁻⁹	372.5 · 10 ⁻⁹	277.8 · 10 ⁻⁹	238 · 10 ⁻⁶	948.4 · 10 ⁻⁶
1 kpm =	7.233	98.07 · 10 ⁶	9.807	1	3.704 · 10 ⁻⁶	3.653 · 10 ⁻⁶	2.725 · 10 ⁻⁶	2.344 · 10 ⁻³	9.301 · 10 ⁻³
1 PSh =	1.953 · 10 ⁶	26.48 · 10 ¹²	2.648 · 10 ⁶	270 · 10 ³	1	0.9863	0.7355	632.5	2510
1 hph =	1.98 · 10 ⁶	26.85 · 10 ¹²	2.685 · 10 ⁶	273.8 · 10 ³	1.014	1	0.7457	641.3	2545
1 kWh =	2.655 · 10 ⁶	36 · 10 ¹²	3.6 · 10 ⁶	367.1 · 10 ³	1.36	1.341	1	860	3413
1 kcal =	3.087 · 10 ³	41.87 · 10 ⁹	4186.8	426.9	1.581 · 10 ⁻³	1.559 · 10 ⁻³	1.163 · 10 ⁻³	1	3.968
1 Btu =	778.6	10.55 · 10 ⁹	1055	107.6	398.4 · 10 ⁻⁶	392.9 · 10 ⁻⁶	293 · 10 ⁻⁶	0.252	1
1 in oz = 0.072 kpcm; 1 in lb = 0.0833ft lb = 0.113 Nm; 1 thermi (French) = 4.1855 · 10 ⁶ J; 1 therm (English) = 105.51 · 10 ⁹ J Common in case of piston engines: 1 litre-atmosphere (litre · atmosphere) = 98.067 J									

Physics

Power, Energy Flow, Heat Flow, Pressure and Tension, Velocity

3

Power, energy flow, heat flow								
Power	erg/s	W	kpm/s	PS	hp	kW	kcal/s	Btu/s
1 erg/s =	1	10 ⁻⁷	0.102 · 10 ⁻⁷	0.136 · 10 ⁻⁹	0.1341 · 10 ⁻⁹	10 ⁻¹⁰	23.9 · 10 ⁻¹²	94.84 · 10 ⁻¹²
1 W =	10 ⁷	1	0.102	1.36 · 10 ⁻³	1.341 · 10 ⁻³	10 ⁻³	239 · 10 ⁻⁶	948.4 · 10 ⁻⁶
1 kpm/s =	9.807 · 10 ⁷	9.807	1	13.33 · 10 ⁻³	13.15 · 10 ⁻³	9.804 · 10 ⁻³	2.344 · 10 ⁻³	9.296 · 10 ⁻³
1 PS (ch) ²⁾ =	7.355 · 10 ⁹	735.5	75	1	0.9863	0.7355	0.1758	0.6972
1 hp =	7.457 · 10 ⁹	745.7	76.04	1.014	1	0.7457	0.1782	0.7068
1 kW =	10 ¹⁰	1000	102	1.36	1.341	1	0.239	0.9484
1 kcal/s =	41.87 · 10 ⁸	4187	426.9	5.692	5.614	4.187	1	3.968
1 Btu/s =	10.55 · 10 ⁹	1055	107.6	1.434	1.415	1.055	0.252	1

1 poncelet (French) = 980.665 W; flywheel effect: 1 kgm² = 3418 lb in²

Pressure and tension													
Unit	μbar = dN/m ²	mbar = cN/cm ²	bar = daN/cm ²	kp/m ² mm WS	p/cm ²	kp/cm ² = at	kp/ mm ²	Torr = mm QS	atm	$\frac{\text{lb}}{\text{sq ft}}$	$\frac{\text{lb}}{\text{sq in}}$	long ton sq in	sh ton sq in
1 μb = daN =	1	0.001	-	0.0102	-	-	-	-	-	-	-	-	-
1 mbar = cN/cm ² =	1000	1	0.001	10.2	1.02	-	-	0.7501	-	2.089	0.0145	-	-
1 bar = daN/cm ² =	10 ⁶	1000	1	10197	1020	1.02	0.0102	750.1	0.9869	2089	14.5	0.0064	0.0072
1 kp/m ² = 1 mm WS at 4 °C =	98.07	-	-	1	0.1	0.0001	-	-	-	0.2048	-	-	-
1 p/cm ² =	980.7	0.9807	-	10	1	0.001	-	0.7356	-	2.048	0.0142	-	-
1 kp/cm ² = 1 at (technical atmosphere) =	-	980.7	0.9807	10000	1000	1	0.01	735.6	0.9678	2048	14.22	-	-
1 kp/mm ² =	-	98067	98.07	10 ⁶	10 ⁵	100	1	73556	96.78	-	1422	0.635	0.7112
1 Torr = 1 mm QS at 0 °C =	1333	1.333	0.00133	13.6	1.36	0.00136	-	1	-	2.785	0.01934	-	-
1 atm (pressure of the atmosphere) =	-	1013	1.013	10332	1033	1.033	-	760	1	2116	14.7	-	-
1 lb/sq ft =	478.8	0.4788	-	4.882	0.4882	-	-	0.3591	-	1	-	-	-
1 lb/sq in = 1 psi =	68948	68.95	0.0689	703.1	70.31	0.0703	-	51.71	0.068	144	1	-	0.0005
1 long ton/sq in (GB) =	-	-	154.4	-	-	157.5	1.575	-	152.4	-	2240	1	1,12
1 short ton/sq in (US) =	-	-	137.9	-	-	140.6	1.406	-	136.1	-	2000	0.8929	1

1 psi = 0.00689 N / mm²
 1 N/m² (Newton/m²) = 10 μb ; 1 barye (French) = 1 μb ; 1 pièce (pz) (French) = 1 sn/m² ≈ 102 kp/m²; 1 hpz = 100 pz = 1.02 kp/m²; 1 micron (USA) = 0.001 mm QS = 0.001 Torr.
 In the USA, "inches Hg" are calculated from the top, i.e. 0 inches Hg = 760 mm QS and 29.92 inches Hg = 0 mm QS = absolute vacuum.
 The specific gravity of mercury is assumed to be 13.595 kg/dm³.

Velocity					
Unit	m/s	m/min	km/h	ft/min	mile/h
m/s =	1	60	3.6	196.72	2.237
m/min =	0.0167	1	0.06	3.279	0.0373
km/h =	0.278	16.67	1	54.645	0.622
ft/min =	0.0051	0.305	0.0183	1	0.0114
mile/h =	0.447	26.82	1.609	87.92	1

Physics

Equations for Linear Motion and Rotary Motion

Definition	SI unit	Symbol	Basic formulae	
			Linear motion	Rotary motion
Uniform motion			distance moved divided by time	angular velocity = angle of rotation in radian measure/time
Velocity	m/s	v	$v = \frac{s_2 - s_1}{t_2 - t_1} = \frac{\Delta s}{\Delta t} = \text{const.}$	$\omega = \frac{\varphi_2 - \varphi_1}{t_2 - t_1} = \frac{\Delta \varphi}{\Delta t} = \text{const.}$
Angular velocity	rad/s	ω	motion accelerated from rest:	
Angle of rotation	rad	φ	$v = \frac{s}{t}$	$\omega = \frac{\varphi}{t}$
Distance moved	m	s	$s = v \cdot t$	angle of rotation $\varphi = \omega \cdot t$
Uniformly accelerated motion			acceleration equals change of velocity divided by time	angular acceleration equals change of angular velocity divided by time
Acceleration	m/s ²	a	$a = \frac{v_2 - v_1}{t_2 - t_1} = \frac{\Delta v}{\Delta t} = \text{const.}$	$\alpha = \frac{\omega_2 - \omega_1}{t_2 - t_1} = \frac{\Delta \omega}{\Delta t} = \text{const.}$
Angular acceleration	rad/s ²	α	motion accelerated from rest:	
Velocity	m/s	v	$a = \frac{v}{t} = \frac{v^2}{2s} = \frac{2s}{t^2}$	$\alpha = \frac{\omega}{t} = \frac{\omega^2}{2\varphi} = \frac{2\varphi}{t^2}$
Circumferential speed	m/s	v	$v = a \cdot t = \sqrt{2 a \cdot s}$	$\omega = \alpha \cdot t$
Distance moved	m	s	$s = \frac{v}{2} \cdot t = \frac{a}{2} \cdot t^2 = \frac{v^2}{2a}$	$v = r \cdot \omega = r \cdot \alpha \cdot t$ angle of rotation $\varphi = \frac{\omega}{2} \cdot t = \frac{\alpha}{2} \cdot t^2 = \frac{\omega^2}{2\alpha}$
Uniform motion and constant force or constant torque			force · distance moved	torque · angle of rotation in radian measure
Work	J	W	$W = F \cdot s$	$W = M \cdot \varphi$
Power	W	P	work in unit of time = force · velocity $P = \frac{W}{t} = F \cdot v$	work in unit of time = torque · angular velocity $P = \frac{W}{t} = M \cdot \omega$
Non-uniform (accelerated) motion			accelerating force = mass · acceleration	accel. torque = second mass moment · angular acceleration
Force	N	F	$F = m \cdot a$	$M = J \cdot \alpha$
In case of any motion			Momentum (kinetic energy) equals half the mass · second power of velocity	Kinetic energy due to rotation equals half the mass moment of inertia · second power of the angular velocity
Energie	J	E_k	$E_k = \frac{m}{2} \cdot v^2$	$E_k = \frac{J}{2} \cdot \omega^2$
Potential energy (due to force of gravity)	J	E_p	weight · height $E_p = G \cdot h = m \cdot g \cdot h$	
Centrifugal force	N	F_F	$F_F = m \cdot r_s \cdot \omega^2$ (r_s = centre-of-gravity radius)	

Table of Contents Section 4

Mathematics / Geometry

Page

Calculation of Areas

45

Calculation of Volumes

46

Mathematics / Geometry
Calculation of Areas

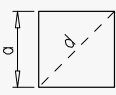
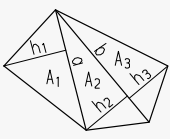
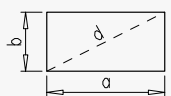
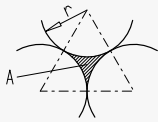
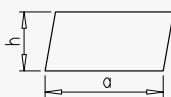
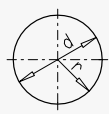
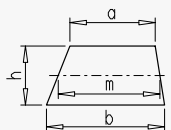
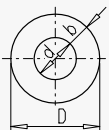
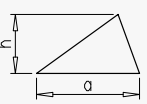
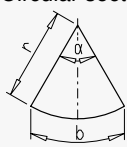
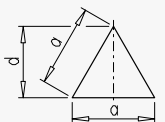
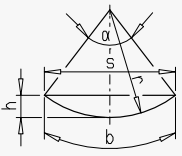
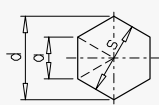
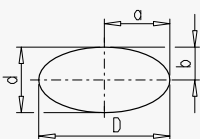
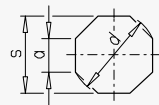
	A = area	U = circumference	
<p>Square</p> 	$A = a^2$ $a = \sqrt{A}$ $d = a\sqrt{2}$	<p>Polygon</p> 	$A = A_1 + A_2 + A_3$ $= \frac{a \cdot h_1 + b \cdot h_2 + c \cdot h_3}{2}$
<p>Rectangle</p> 	$A = a \cdot b$ $d = \sqrt{a^2 + b^2}$	<p>Formed area</p> 	$A = \frac{r^2}{2} (2\sqrt{3} - \pi)$ $\approx 0.16 \cdot r^2$
<p>Parallelogram</p> 	$A = a \cdot h$ $a = \frac{A}{h}$	<p>Circle</p> 	$A = \frac{d^2 \cdot \pi}{4} = r^2 \cdot \pi$ $\approx 0.785 \cdot d^2$ $U = 2 \cdot r \cdot \pi = d \cdot \pi$
<p>Trapezium</p> 	$A = m \cdot h$ $m = \frac{a + b}{2}$	<p>Circular ring</p> 	$A = \frac{\pi}{4} \cdot (D^2 - d^2)$ $= (d + b) b \cdot \pi$ $b = \frac{D - d}{2}$
<p>Triangle</p> 	$A = \frac{a \cdot h}{2}$ $a = \frac{2 \cdot A}{h}$	<p>Circular sector</p> 	$A = \frac{r^2 \cdot \pi \cdot \alpha^\circ}{360^\circ}$ $= \frac{b \cdot r}{2}$ $b = \frac{r \cdot \pi \cdot \alpha^\circ}{180^\circ}$
<p>Equilateral triangle</p> 	$A = \frac{a^2 \sqrt{3}}{4}$ $d = \frac{a}{2} \sqrt{3}$	<p>Circular segment</p> 	$A = \frac{r^2}{2} \left(\frac{\alpha^\circ \cdot \pi}{180^\circ} - \sin \alpha \right)$ $= \frac{1}{2} [r(b - s) + sh]$ $s = 2r \sin \frac{\alpha}{2}$ $h = r \left(1 - \cos \frac{\alpha}{2} \right) = \frac{s}{2} \tan \frac{\alpha}{4}$ $\hat{\alpha} = \frac{\alpha^\circ \cdot \pi}{180^\circ}$ $b = r \cdot \hat{\alpha}$
<p>Hexagon</p> 	$A = \frac{3 \cdot a^2 \cdot \sqrt{3}}{2}$ $d = 2 \cdot a$ $s = \sqrt{3} \cdot a$	<p>Ellipse</p> 	$A = \frac{D \cdot d \cdot \pi}{4} = a \cdot b \cdot \pi$ $U \approx \frac{D + d}{2} \cdot \pi$ $U = \pi (a + b) \left[1 + \frac{1}{4} \left(\frac{a-b}{a+b} \right)^2 + \frac{1}{64} \left(\frac{a-b}{a+b} \right)^4 + \frac{1}{256} \left(\frac{a-b}{a+b} \right)^6 \dots \right]$
<p>Octagon</p> 	$A = 2a^2 (\sqrt{2} + 1)$ $d = a\sqrt{4 + 2\sqrt{2}}$ $s = a(\sqrt{2} + 1)$		

	V = volume	O = surface	M = generated surface
<p>Cube</p> 	$V = a^3$ $O = 6 \cdot a^2$ $d = a\sqrt{3}$	<p>Frustum of cone</p> 	$V = \frac{\pi \cdot h}{12} (D^2 + Dd + d^2)$ $M = \frac{\pi \cdot m}{2} (D + d)$ $= 2 \cdot \pi \cdot p \cdot h$ $m = \sqrt{\left(\frac{D-d}{2}\right)^2 + h^2}$
<p>Square prism</p> 	$V = a \cdot b \cdot c$ $O = 2(ab + ac + bc)$ $d = \sqrt{a^2 + b^2 + c^2}$	<p>Sphere</p> 	$V = \frac{4}{3} r^3 \pi = \frac{1}{6} \cdot d^3 \pi$ $\approx 4.189 \cdot r^3$ $O = 4 \pi \cdot r^2 = \pi \cdot d^2$
<p>Parallelepiped</p> 	$V = A \cdot h$ <p>(Cavalier principle)</p>	<p>Spherical zone</p> 	$V = \frac{\pi \cdot h}{6} (3a^2 + 3b^2 + h^2)$ $M = 2 \cdot r \cdot \pi \cdot h$
<p>Pyramid</p> 	$V = \frac{A \cdot h}{3}$	<p>Spherical segment</p> 	$V = \frac{\pi \cdot h}{6} \left(\frac{3}{4} s^2 + h^2\right)$ $= \pi h^2 \left(r - \frac{h}{3}\right)$ $M = 2 \cdot r \cdot \pi \cdot h$ $= \frac{\pi}{4} (s^2 + 4h^2)$
<p>Frustum of pyramid</p> 	$V = \frac{h}{3} (A_1 + A_2 + \sqrt{A_1 \cdot A_2})$	<p>Spherical sector</p> 	$V = \frac{2}{3} \cdot h \cdot r^2 \cdot \pi$ $O = \frac{\pi \cdot r}{2} (4h + s)$
<p>Cylinder</p> 	$V = \frac{d^2 \cdot \pi}{4} h$ $M = 2 \cdot r \cdot \pi \cdot h$ $O = 2 \cdot r \cdot \pi \cdot (r + h)$	<p>Cylindrical ring</p> 	$V = \frac{D \cdot \pi^2 \cdot d^2}{4} h$ $O = D \cdot d \cdot \pi^2$
<p>Hollow cylinder</p> 	$V = \frac{h \cdot \pi}{4} (D^2 - d^2)$	<p>Barrel</p> 	$V = \frac{h \cdot \pi}{12} (2D^2 + d^2)$
<p>Cone</p> 	$V = \frac{r^2 \cdot \pi \cdot h}{3}$ $M = r \cdot \pi \cdot m$ $O = r \cdot \pi \cdot (r + m)$ $m = \sqrt{h^2 + \left(\frac{d}{2}\right)^2}$	<p>Prismatoid</p> 	$V = \frac{h}{6} (A_1 + A_2 + 4A)$

Table of Contents Section 5

Mechanics / Strength of Materials	Page
Axial Section Moduli and Axial Second Moments of Area (Moments of Inertia) of Different Profiles	48
Deflections in Beams	49
Values for Circular Sections	50
Stresses on Structural Members and Fatigue Strength of Structures	51

Mechanics / Strength of Materials

Axial Section Moduli and Axial

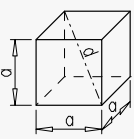
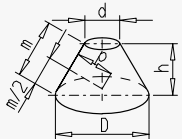
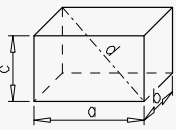
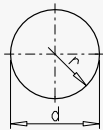
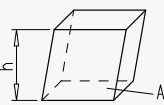
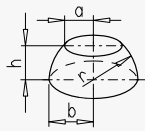
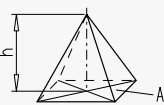
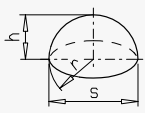
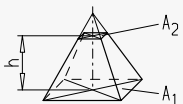
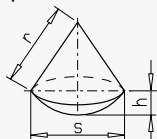
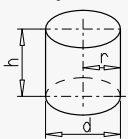
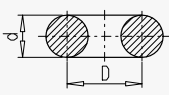
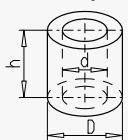
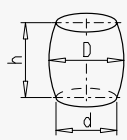
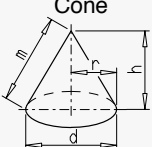
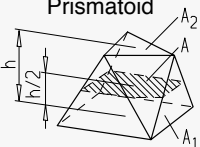
Second Moments of Area

(Moments of Inertia) of Different Profiles

Cross-sectional area	Section modulus	Second moment of area
	$W_1 = bh^2/6$ $W_2 = hb^2/6$	$I_1 = bh^3/12$ $I_2 = hb^3/12$
	$W_1 = W_2 = a^3/6$	$I_1 = I_2 = a^4/12$
	$W_1 = bh^2/24$ for $e = \frac{2}{3}h$ $W_2 = hb^2/24$	$I_1 = bh^3/36$ $I_2 = hb^3/48$
	$W_1 = \frac{5}{8}R^3 = 0.625R^3$ $W_2 = 0.5413R^3$	$I_1 = I_2 = \frac{5}{16}\sqrt{3}R^4 = 0.5413R^4$
	$W_1 = \frac{6b^2 + 6bb_1 + b_1^2}{12(3b + 2b_1)}h^2$ for $e = \frac{1}{3} \frac{3b + 2b_1}{2b + b_1}h$	$I_1 = \frac{6b^2 + 6bb_1 + b_1^2}{36(2b + b_1)}h^3$
	$W_1 = \frac{BH^3 - bh^3}{6H}$	$I_1 = \frac{BH^3 - bh^3}{12}$
	$W_1 = W_2 = \pi D^3/32 \approx D^3/10$	$I_1 = I_2 = \pi D^4/64 \approx D^4/20$
	$W_1 = W_2 = \frac{\pi}{32} \frac{D^4 - d^4}{D}$ or in case of thin wall thickness s: $W_1 = W_2 = I/(r + s/2) \approx \pi sr^2$	$I_1 = I_2 = \frac{\pi}{64} (D^4 - d^4)$ $I_1 = I_2 = \pi sr^3 [1 + (s/2r)^2] \approx \pi sr^3$
	$W_1 = \pi a^2 b/4$ $W_2 = \pi b^2 a/4$	$I_1 = \pi a^3 b/4$ $I_2 = \pi b^3 a/4$
	$W_1 = I_1/a_1$ or in case of thin wall thickness s: $s = a_1 - a_2 = b_1 - b_2 = 2(a - a_2) = 2(b - b_2)$ $W_1 \approx \frac{\pi}{4} a(a + 3b)s$	$I_1 = \frac{\pi}{4} (a_1^3 b_1 - a_2^3 b_2)$ $I_1 \approx \frac{\pi}{4} a^2 (a + 3b)s$
	$W_1 = I_1/e = 0.1908r^3$ with $e = r \left(1 - \frac{4}{3\pi}\right) = 0.5756r$	$I_1 = [\pi/8 - 8/(9\pi)]r^4 = 0.1098r^4$ axis 1-1 = axis of centre of gravity

Mechanics / Strength of Materials

Deflections in Beams

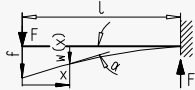
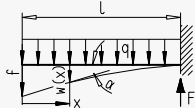
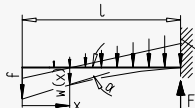
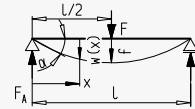
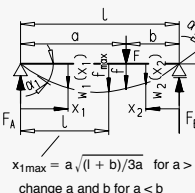
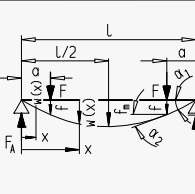
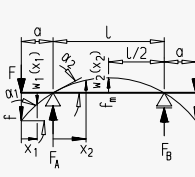
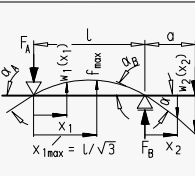
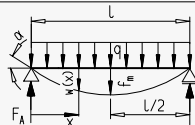
$f, f_{\max}, f_m, w, w_1, w_2$ $a, b, l, x_1, x_{1\max}, x_2$ E q, q_0	Deflection (mm) Lengths (mm) Modulus of elasticity (N/mm ²) Line load (N/mm)	$\alpha, \alpha_1, \alpha_2, \alpha_A, \alpha_B$ Angles (°) F, F_A, F_B Forces (N) I Second moment of area (mm ⁴) (moment of inertia)
	$w(x) = \frac{F l^3}{3EI} \left[1 - \frac{3}{2} \cdot \frac{x}{l} + \frac{1}{2} \left(\frac{x}{l} \right)^3 \right]$ $F_B = F$	$f = \frac{F l^3}{3EI} \quad \tan \alpha = \frac{F l^2}{2EI}$
	$w(x) = \frac{q l^4}{8EI} \left[1 - \frac{4}{3} \cdot \frac{x}{l} + \frac{1}{3} \left(\frac{x}{l} \right)^4 \right]$ $F_B = q \cdot l$	$f = \frac{q l^4}{8EI} \quad \tan \alpha = \frac{q l^3}{6EI}$
	$w(x) = \frac{q_0 l^4}{120EI} \left[4 - 5 \cdot \frac{x}{l} + \left(\frac{x}{l} \right)^5 \right]$ $F_B = \frac{q_0 \cdot l}{2}$	$f = \frac{q_0 l^4}{30EI} \quad \tan \alpha = \frac{q_0 l^3}{24EI}$
	$w(x) = \frac{F l^3}{16EI} \cdot \frac{x}{l} \left[1 - \frac{4}{3} \left(\frac{x}{l} \right)^2 \right] \quad x \leq \frac{l}{2}$ $F_A = F_B = \frac{F}{2}$	$f = \frac{F l^3}{48EI} \quad \tan \alpha = \frac{F l^2}{16EI}$
 <p>$x_{1\max} = a \sqrt{(l+b)/3a}$ for $a > b$ change a and b for $a < b$</p>	$w_1(x_1) = \frac{F l^3}{6EI} \cdot \frac{a}{l} \left(\frac{b}{l} \right)^2 \frac{x_1}{l} \left(1 + \frac{1}{b} - \frac{x_1^2}{ab} \right) \quad x_1 \leq a$ $w_2(x_2) = \frac{F l^3}{6EI} \cdot \frac{b}{l} \left(\frac{a}{l} \right)^2 \frac{x_2}{l} \left(1 + \frac{1}{a} - \frac{x_2^2}{ab} \right) \quad x_2 \leq b$ $f_{\max} = f \frac{l+b}{3b} \sqrt{\frac{l+b}{3a}} \quad \tan \alpha_2 = \frac{f}{2b} \left(1 + \frac{1}{a} \right)$ $F_A = F \frac{b}{l} \quad F_B = F \frac{a}{l}$	$f = \frac{F l^3}{3EI} \left(\frac{a}{l} \right)^2 \left(\frac{b}{l} \right)^2 \quad \tan \alpha_1 = \frac{f}{2a} \left(1 + \frac{1}{b} \right)$
	$w(x) = \frac{F l^3}{2EI} \cdot \frac{x}{l} \left[\frac{a}{l} \left(1 - \frac{a}{l} \right) - \frac{1}{3} \left(\frac{x}{l} \right)^2 \right] \quad x \leq a < l/2$ $w(x) = \frac{F l^3}{2EI} \cdot \frac{a}{l} \left[\frac{x}{l} \left(1 - \frac{x}{l} \right) - \frac{1}{3} \left(\frac{a}{l} \right)^2 \right] \quad a \leq x \leq l/2$ $f_m = \frac{F l^3}{8EI} \cdot \frac{a}{l} \left[1 - \frac{4}{3} \left(\frac{a}{l} \right)^2 \right]$ $F_A = F_B = F$	$f = \frac{F l^3}{2EI} \left(\frac{a}{l} \right)^2 \left(1 - \frac{4}{3} \cdot \frac{a}{l} \right) \quad \tan \alpha_1 = \frac{F l^2}{2EI} \cdot \frac{a}{l} \left(1 - \frac{a}{l} \right)$ $\tan \alpha_2 = \frac{F l^2}{2EI} \cdot \frac{a}{l} \left(1 - 2 \frac{a}{l} \right)$
	$w_1(x_1) = \frac{F l^3}{2EI} \left[\frac{1}{3} \left(\frac{x_1}{l} \right)^3 - \frac{a}{l} \left(1 + \frac{a}{l} \right) \frac{x_1}{l} + \left(\frac{a}{l} \right)^2 \left(1 + \frac{2}{3} \cdot \frac{a}{l} \right) \right] \quad x_1 \leq a$ $f = \frac{F l^3}{2EI} \left(\frac{a}{l} \right)^2 \left(1 + \frac{2}{3} \cdot \frac{a}{l} \right) \quad \tan \alpha_1 = \frac{F l^2}{2EI} \cdot \frac{a}{l} \left(1 + \frac{a}{l} \right)$ $w_2(x_2) = \frac{F l^3}{2EI} \cdot \frac{a}{l} \cdot \frac{x_2}{l} \left(1 - \frac{x_2}{l} \right) \quad x_2 \leq l$ $f_m = \frac{F l^3}{8EI} \cdot \frac{a}{l} \quad \tan \alpha_2 = \frac{F l^2}{2EI} \cdot \frac{a}{l}$ $F_A = F_B = F$	
	$w_1(x_1) = \frac{F l^3}{6EI} \cdot \frac{a}{l} \cdot \frac{x_1}{l} \left[1 - \left(\frac{x_1}{l} \right)^2 \right] \quad x_1 \leq l$ $w_2(x_2) = \frac{F l^3}{6EI} \cdot \frac{x_2}{l} \left[\frac{2a}{l} + \frac{3a}{l} \cdot \frac{x_2}{l} - \left(\frac{x_2}{l} \right)^2 \right] \quad x_2 \leq a$ $f_{\max} = \frac{F l^3}{9\sqrt{3}EI} \cdot \frac{a}{l} \quad \tan \alpha_B = 2 \tan \alpha_A$ $F_A = F \frac{a}{l} \quad F_B = F \left(1 + \frac{a}{l} \right) \quad \tan \alpha = \frac{F l^2}{6EI} \cdot \frac{a}{l} \left(2 + 3 \frac{a}{l} \right)$	$f = \frac{F l^3}{3EI} \left(\frac{a}{l} \right)^2 \left(1 + \frac{a}{l} \right) \quad \tan \alpha_A = \frac{F l^2}{6EI} \cdot \frac{a}{l}$
	$w(x) = \frac{q l^4}{24EI} \cdot \frac{x}{l} \left[1 - 2 \left(\frac{x}{l} \right)^2 + \left(\frac{x}{l} \right)^3 \right] \quad 0 \leq x \leq l$ $F_A = \frac{q \cdot l}{2} \quad F_B = \frac{q \cdot l}{2}$	$f_m = \frac{5q l^4}{384EI} \quad \tan \alpha = \frac{q l^3}{24EI}$

Mechanics / Strength of Materials

Values for Circular Sections

Axial section modulus:	$W_a = \frac{\pi \cdot d^3}{32}$	Area:	$A = \frac{\pi \cdot d^2}{4}$
Polar section modulus:	$W_p = \frac{\pi \cdot d^3}{16}$	Mass:	$m = \frac{\pi \cdot d^2}{4} \cdot l \cdot \rho$
Axial second moment of area (axial moment of inertia):	$I_a = \frac{\pi \cdot d^4}{64}$	Density of steel:	$\rho = 7.85 \frac{\text{kg}}{\text{dm}^3}$
Polar second moment of area (polar moment of area):	$I_p = \frac{\pi \cdot d^4}{32}$	Second mass moment of inertia (mass moment of inertia):	$J = \frac{\pi \cdot d^4 \cdot l \cdot \rho}{32}$

d mm	A cm ²	W _a cm ³	I _a cm ⁴	Mass/l kg/m	J/l kgm ² /m	d mm	A cm ²	W _a cm ³	I _a cm ⁴	Mass/l kg/m	J/l kgm ² /m
6	0.293	0.0212	0.0064	0.222	0.000001	115	103.869	149.3116	858.5414	81.537	0.134791
7	0.385	0.0337	0.0118	0.302	0.000002	120	113.097	169.6460	1017.8760	88.781	0.159807
8	0.503	0.0503	0.0201	0.395	0.000003	125	122.718	191.7476	1198.4225	96.334	0.188152
9	0.636	0.0716	0.0322	0.499	0.000005	130	132.732	215.6900	1401.9848	104.195	0.220112
10	0.785	0.0982	0.0491	0.617	0.000008	135	143.139	241.5468	1630.4406	112.364	0.255979
11	0.950	0.1307	0.0719	0.746	0.000011	140	153.938	269.3916	1895.7410	120.841	0.296061
12	1.131	0.1696	0.1018	0.888	0.000016	145	165.130	299.2981	2169.9109	129.627	0.340676
13	1.327	0.2157	0.1402	1.042	0.000022	150	176.715	331.3398	2485.0489	138.721	0.390153
14	1.539	0.2694	0.1986	1.208	0.000030	155	188.692	365.5906	2833.3269	148.123	0.444832
15	1.767	0.3313	0.2485	1.387	0.000039	160	201.062	402.1239	3216.9909	157.834	0.505068
16	2.011	0.4021	0.3217	1.578	0.000051	165	213.825	441.0133	3638.3601	167.852	0.571223
17	2.270	0.4823	0.4100	1.782	0.000064	170	226.980	482.3326	4099.8275	178.179	0.643673
18	2.545	0.5726	0.5153	1.998	0.000081	175	240.528	526.1554	4603.8598	188.815	0.722806
19	2.835	0.6734	0.6397	2.226	0.000100	180	254.469	572.5553	5152.9973	199.758	0.809021
20	3.142	0.7854	0.7854	2.466	0.000123	185	268.803	621.6058	5749.8539	211.010	0.902727
21	3.464	0.9092	0.9547	2.719	0.000150	190	283.529	673.3807	6397.1171	222.570	1.004347
22	3.801	1.0454	1.1499	2.984	0.000181	195	298.648	727.9537	7097.5481	234.438	1.114315
23	4.155	1.1945	1.3737	3.261	0.000216	200	314.159	785.3982	7853.9816	246.615	1.233075
24	4.524	1.3572	1.6286	3.551	0.000256	210	346.361	909.1965	9546.5638	271.893	1.498811
25	4.909	1.5340	1.9175	3.853	0.000301	220	380.133	1045.3650	11499.0145	298.404	1.805345
26	5.309	1.7255	2.2432	4.168	0.000352	230	415.476	1194.4924	13736.6629	326.148	2.156656
27	5.726	1.9324	2.6087	4.495	0.000410	240	452.389	1357.1680	16286.0163	355.126	2.556905
28	6.158	2.1551	3.0172	4.834	0.000474	250	490.874	1533.9808	19174.7598	385.336	3.010437
29	6.605	2.3944	3.4719	5.185	0.000545	260	530.929	1725.5198	22431.7569	416.779	3.521786
30	7.069	2.6507	3.9761	5.549	0.000624	270	572.555	1932.3740	26087.0491	449.456	4.095667
32	8.042	3.2170	5.1472	6.313	0.000808	280	615.752	2155.1326	30171.8558	483.365	4.736981
34	9.079	3.8587	6.5597	7.127	0.001030	300	706.858	2650.7188	39760.7820	554.884	6.242443
36	10.179	4.5804	8.2448	7.990	0.001294	320	804.248	3216.9909	51471.8540	631.334	8.081081
38	11.341	5.3870	10.2354	8.903	0.001607	340	907.920	3858.6612	65597.2399	712.717	10.298767
40	12.566	6.2832	12.5664	9.865	0.001973	360	1017.876	4580.4421	82447.9575	799.033	12.944329
42	13.854	7.2736	15.2745	10.876	0.002398	380	1134.115	5387.0460	102353.8739	890.280	16.069558
44	15.205	8.3629	18.3984	11.936	0.002889	400	1256.637	6283.1853	125663.7060	986.460	19.729202
46	16.619	9.5559	21.9787	13.046	0.003451	420	1385.442	7273.5724	152745.0207	1087.572	23.980968
48	18.096	10.8573	26.0576	14.205	0.004091	440	1520.531	8362.9196	183984.2320	1193.617	28.885524
50	19.635	12.2718	30.6796	15.413	0.004817	460	1661.903	9555.9364	219786.6072	1304.593	34.506497
52	21.237	13.9042	35.8908	16.671	0.005635	480	1809.557	10857.3442	260576.2608	1420.503	40.910473
54	22.902	15.4590	41.7393	17.978	0.006553	500	1963.495	12271.8463	306796.1572	1541.344	48.166997
56	24.630	17.2411	48.2750	19.335	0.007579	520	2123.717	13804.1581	358908.1107	1667.118	56.348573
58	26.421	19.1551	55.5497	20.740	0.008721	540	2290.221	15458.9920	417392.7849	1797.824	65.530667
60	28.274	21.2058	63.6173	22.195	0.009988	560	2463.009	17241.0605	482749.6930	1933.462	75.791702
62	30.191	23.3978	72.5332	23.700	0.011388	580	2642.079	19155.0758	555497.1978	2074.032	87.213060
64	32.170	25.7359	82.3550	25.253	0.012930	600	2827.433	21205.7504	636172.5116	2219.535	99.879084
66	34.212	28.2249	93.1420	26.856	0.014623	620	3019.071	23397.7967	725331.6994	2369.970	113.877076
68	36.317	30.8693	104.9556	28.509	0.016478	640	3216.991	25735.9270	823549.6636	2525.338	129.297297
70	38.485	33.6739	117.8588	30.210	0.018504	660	3421.194	28224.8538	931420.1743	2685.638	146.232967
72	40.715	36.6435	131.9167	31.961	0.020711	680	3631.681	30869.2894	1049555.8389	2850.870	164.780267
74	43.008	39.7828	147.1963	33.762	0.023110	700	3848.451	33673.9462	1178588.1176	3021.034	185.038334
76	45.365	43.0964	163.7662	35.611	0.025711	720	4071.504	36643.5367	1319167.3201	3196.131	207.109269
78	47.784	46.5890	181.6972	37.510	0.028526	740	4300.840	39782.7731	1471962.6056	3376.160	231.098129
80	50.265	50.2655	201.0619	39.458	0.031567	760	4536.460	43096.3680	1637661.9830	3561.121	257.112931
82	52.810	54.1304	221.9347	41.456	0.034844	780	4778.362	46589.0336	1816972.3105	3751.015	285.264653
84	55.418	58.1886	244.3920	43.503	0.038370	800	5026.548	50265.4824	2010619.2960	3945.840	315.667229
86	58.088	62.4447	268.5120	45.599	0.042156	820	5281.017	54130.4268	2219347.4971	4145.599	348.437557
88	60.821	66.9034	294.3748	47.745	0.046217	840	5541.769	58188.5791	2443920.3207	4350.289	383.695490
90	63.617	71.5694	322.0623	49.940	0.050564	860	5808.805	62444.6517	2685120.0234	4559.912	421.563844
92	66.476	76.4475	351.6586	52.184	0.055210	880	6082.123	66903.3571	2943747.7413	4774.467	462.168391
95	70.882	84.1726	399.8198	55.643	0.062772	900	6361.725	71569.4076	3220623.3010	4993.954	505.637864
100	78.540	98.1748	490.8739	61.654	0.077067	920	6647.610	76447.5155	3516585.7151	5218.374	552.103957
105	86.590	113.6496	596.6602	67.973	0.093676	940	6939.778	81542.3934	3832420.1910	5447.726	601.701321
110	95.033	130.6706	718.6884	74.601	0.112834	960	7238.229	86858.7536	4189292.4722	5682.010	654.567567
						980	7542.964	92401.3084	4527664.1126	5921.227	710.843266
						1000	7853.982	98174.7703	4908738.5156	6165.376	770.671947

Mechanics / Strength of Materials

Stresses on Structural Members and Fatigue Strength of Structures

Diffusion of stress in structural members: loading types

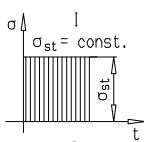

static

Maximum stress limit:
Mean stress:
Minimum stress limit:

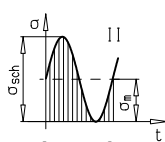

dynamic

$\sigma_o = \sigma_{sch}$
 $\sigma_m = \sigma_{sch}/2$
 $\sigma_u = 0$

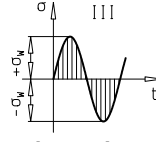

alternating

$\sigma_o = +\sigma_w$
 $\sigma_m = 0$
 $\sigma_u = -\sigma_w$

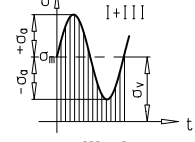

oscillating

$\sigma_o = \sigma_m + \sigma_a$
 $\sigma_m = \sigma_v$ (initial stress)
 $\sigma_u = \sigma_m - \sigma_a$

Ruling coefficient of strength of material for the calculation of structural members:

Resistance to breaking R_m
Yield point R_e ; $R_{p0.2}$

Fatigue strength under fluctuating stresses σ_{sch}

Fatigue strength under alternating stresses σ_w

Resistance to deflection σ_A

Coefficients of fatigue strength σ_D

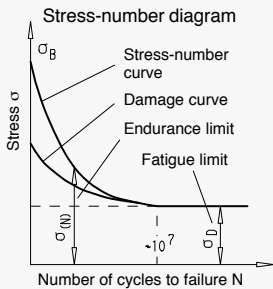

In case of stresses below the damage curve initial damage will not occur to the material.

Example:
Tension-Compression

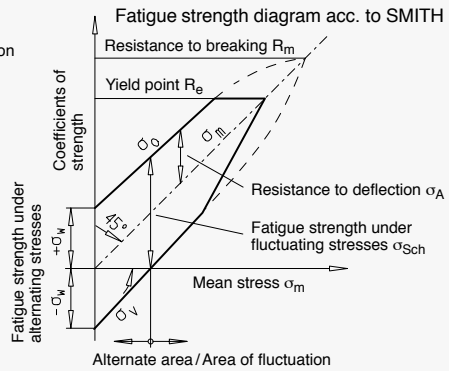

Reduced stress on the member

Permissible stress

Design strength of the member

with: σ_D = ruling fatigue strength value of the material

$$\sigma_v \leq \sigma_{perm.} = \frac{\sigma_D \cdot b_0 \cdot b_d}{S \cdot \beta_k}$$

b_0 = surface number (≤ 1)

b_d = size number (≤ 1)

β_k = stress concentration factor (≥ 1)

S = safety (1.2 ... 2)

Reduced stress σ_v

For the frequently occurring case of combined bending and torsion, according to the distortion energy theory:

with:

σ = single axis bending stress

τ = torsional stress

α_0 = constraint ratio according to Bach

$$\sigma_v = \sqrt{\sigma^2 + 3(\alpha_0\tau)^2}$$

Alternating bending, dynamic torsion: $\alpha_0 \approx 0.7$

Alternating bending, alternating torsion: $\alpha_0 \approx 1.0$

Static bending, alternating torsion: $\alpha_0 \approx 1.6$

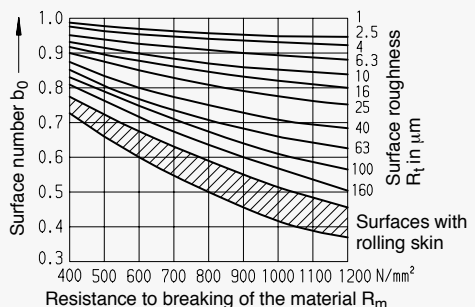
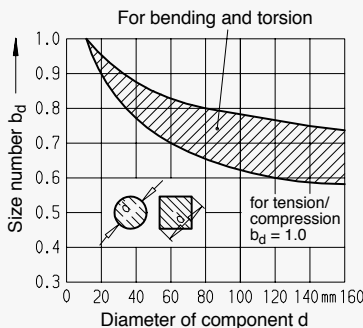

Table of Contents Section 6

Hydraulics

Page

Hydrostatics

53

(Source: K. Gieck, Technische Formelsammlung, 29th edition, Gieck Verlag, Heilbronn)

Hydrodynamics

54

(Source: K. Gieck, Technische Formelsammlung, 29th edition, Gieck Verlag, Heilbronn)

Pressure distribution in a fluid

$$p_1 = p_0 + g \varrho h_1$$

$$p_2 = p_1 + g \varrho (h_2 - h_1) = p_1 + g \varrho \Delta h$$

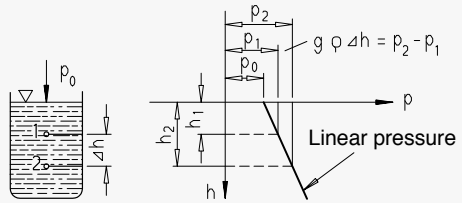

Hydrostatic force of pressure on planes

The hydrostatic force of pressure F is that force which is exerted on the wall by the fluid only - i.e. without consideration of pressure p_0 .

$$F = g \varrho y_s A \cos \alpha = g \varrho h_s A$$

$$y_D = \frac{I_x}{y_s A} = y_s + \frac{I_s}{y_s A} ; \quad x_D = \frac{I_{xy}}{y_s A} \quad \text{m, mm}$$

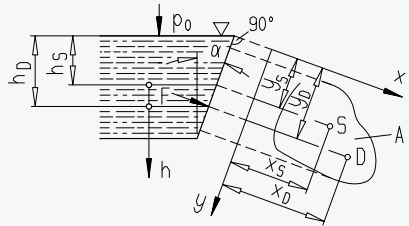

Hydrostatic force of pressure on curved surfaces

The hydrostatic force of pressure on the curved surface 1 - 2 is resolved into a horizontal component F_H and a vertical component F_V . F_V is equal to the weight of the fluid having a volume V located (a) or thought to be located (b) over the surface 1 - 2. The line of application runs through the centre of gravity.

$$|F_V| = g \varrho V \quad (\text{N, kN})$$

F_H is equal to the hydrostatic force of pressure on the projection of surface 1 - 2 perpendicular to F_H .

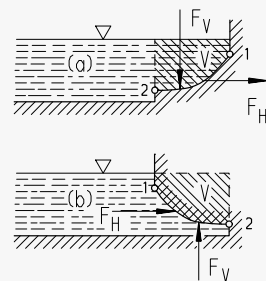

Buoyance

The buoyant force F_A is equal to the weight of the displaced fluids having densities ϱ and ϱ' .

$$F_A = g \varrho V + g \varrho' V' \quad (\text{N, kN})$$

If the fluid with density ϱ' is a gas, the following applies:

$$F_A \approx g \varrho V \quad (\text{N, kN})$$

For ϱ_k density of the body applies:

- $\varrho > \varrho_k$ the body floats
 - $\varrho = \varrho_k$ the body is suspended
 - $\varrho < \varrho_k$ the body sinks
- } in the liquid

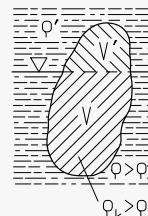

- S = centre of gravity of plane A
- D = centre of pressure
- I_x, I_s = moments of inertia
- I_{xy} = product of inertia of plane A referred to the x- and y-axes

Discharge of liquids from vessels	
Vessel with bottom opening	
$v = \varphi \sqrt{2 g H}$ $\dot{V} = \varphi \varepsilon A \sqrt{2 g H}$	
Vessel with small lateral opening	
$v = \varphi \sqrt{2 g H}$ $s = 2 \sqrt{H h}$ (without any coefficient of friction) $\dot{V} = \varphi \varepsilon A \sqrt{2 g H}$ $F = \rho \dot{V} v$	
Vessel with wide lateral opening	
$\dot{V} = \frac{2}{3} \varepsilon b \sqrt{2 g} (H_2^{3/2} - H_1^{3/2})$	
Vessel with excess pressure on liquid level	
$v = \varphi \sqrt{2 \left(g H + \frac{p_{\bar{u}}}{\rho} \right)}$ $\dot{V} = \varphi \varepsilon A \sqrt{2 \left(g H + \frac{p_{\bar{u}}}{\rho} \right)}$	
Vessel with excess pressure on outlet	
$v = \varphi \sqrt{2 \frac{p_{\bar{u}}}{\rho}}$ $\dot{V} = \varphi \varepsilon A \sqrt{2 \frac{p_{\bar{u}}}{\rho}}$	
<p>v: discharge velocity g: gravity ρ: density p_ū: excess pressure compared to external pressure φ: coefficient of friction (for water φ = 0.97) ε: coefficient of contraction (ε = 0.62 for sharp-edged openings) (ε = 0.97 for smooth-rounded openings) F: force of reaction Ṃ: volume flow rate b: width of opening</p>	

Table of Contents Section 7

Electrical Engineering	Page
Basic Formulae	56
Speed, Power Rating and Efficiency of Electric Motors	57
Types of Construction and Mounting Arrangements of Rotating Electrical Machinery	58
Types of Protection for Electrical Equipment (Protection Against Contact and Foreign Bodies)	59
Types of Protection for Electrical Equipment (Protection Against Water)	60

Electrical Engineering

Basic Formulae

Ohm's law: $U = I \cdot R \quad I = \frac{U}{R} \quad R = \frac{U}{I}$			Material	γ $\left[\frac{\text{m}}{\Omega \text{ mm}^2} \right]$	ϱ $\left[\frac{\Omega \text{ mm}^2}{\text{m}} \right]$													
Series connection of resistors: $R = R_1 + R_2 + R_3 + \dots + R_n$ R = total resistance [Ω] R_n = individual resistance [Ω]			a) Metals Aluminium 36 Bismuth 0.83 Lead 4.84 Cadmium 13 Iron wire 6.7...10 Gold 43.5 Copper 58 Magnesium 22 Nickel 14.5 Platinum 9.35 Mercury 1.04 Silver 61 Tantalum 7.4 Tungsten 18.2 Zinc 16.5 Tin 8.3	0.0278 1.2 0.2066 0.0769 0.15..0,1 0.023 0.01724 0.045 0.069 0.107 0.962 0.0164 0.135 0.055 0.061 0.12														
Shunt connection of resistors: $\frac{1}{R} = \frac{1}{R_1} + \frac{1}{R_2} + \frac{1}{R_3} + \dots + \frac{1}{R_n}$ R = total resistance [Ω] R_n = individual resistance [Ω]																		
Electric power: <table border="1" style="width:100%; border-collapse: collapse;"> <thead> <tr> <th></th> <th>Power</th> <th>Current consumption</th> </tr> </thead> <tbody> <tr> <td>Direct current</td> <td>$P = U \cdot I$</td> <td>$I = \frac{P}{U}$</td> </tr> <tr> <td>Single-phase alternating current</td> <td>$P = U \cdot I \cdot \cos \varphi$</td> <td>$I = \frac{P}{U \cdot \cos \varphi}$</td> </tr> <tr> <td>Three-phase current</td> <td>$P = 1.73 \cdot U \cdot I \cdot \cos \varphi$</td> <td>$I = \frac{P}{1.73 \cdot U \cdot \cos \varphi}$</td> </tr> </tbody> </table>						Power	Current consumption	Direct current	$P = U \cdot I$	$I = \frac{P}{U}$	Single-phase alternating current	$P = U \cdot I \cdot \cos \varphi$	$I = \frac{P}{U \cdot \cos \varphi}$	Three-phase current	$P = 1.73 \cdot U \cdot I \cdot \cos \varphi$	$I = \frac{P}{1.73 \cdot U \cdot \cos \varphi}$	b) Alloys Aldrey (AlMgSi) 30.0 Bronze I 48 Bronze II 36 Bronze III 18 Constantan (WM 50) 2.0 Manganin 2.32 Brass 15.9 Nickel silver (WM 30) 3.33 Nickel chromium 0.92 Niccolite (WM 43) 2.32 Platinum rhodium 5.0 Steel wire (WM 13) 7.7 Wood's metal 1.85	0.033 0.02083 0.02778 0.05556 0.50 0.43 0.063 0.30 1.09 0.43 0.20 0.13 0.54
	Power	Current consumption																
Direct current	$P = U \cdot I$	$I = \frac{P}{U}$																
Single-phase alternating current	$P = U \cdot I \cdot \cos \varphi$	$I = \frac{P}{U \cdot \cos \varphi}$																
Three-phase current	$P = 1.73 \cdot U \cdot I \cdot \cos \varphi$	$I = \frac{P}{1.73 \cdot U \cdot \cos \varphi}$																
Resistance of a conductor: $R = \frac{l}{\gamma \cdot A} = \frac{l \cdot \varrho}{A}$ R = resistance (Ω) l = length of conductor (m) γ = electric conductivity ($\text{m}/\Omega \text{ mm}^2$) A = cross section of conductor (mm^2) ϱ = specific electrical resistance ($\Omega \text{ mm}^2/\text{m}$)			c) Other conductors Graphite 0.046 Carbon, homog. 0.015 Retort graphite 0.014	22 65 70														

Electrical Engineering

Speed, Power Rating and Efficiency of Electric Motors

Speed:

$$n = \frac{f \cdot 60}{p}$$

n = speed (min^{-1})

f = frequency (Hz)

p = number of pole pairs

Example: $f = 50 \text{ Hz}$, $p = 2$

$$n = \frac{50 \cdot 60}{2} = 1500 \text{ min}^{-1}$$

Efficiency:

$$\eta = \frac{P_{ab}}{P_{zu}} \cdot 100 [\%]^{1)}$$

Example:

Efficiency and power factor of a four-pole 1.1-kW motor and a 132-kW motor dependent on the load

Power rating:

Output power ¹⁾

Direct current:

$$P_{ab} = U \cdot I \cdot \eta$$

Single-phase alternating current:

$$P_{ab} = U \cdot I \cdot \cos \varphi \cdot \eta$$

Three-phase current:



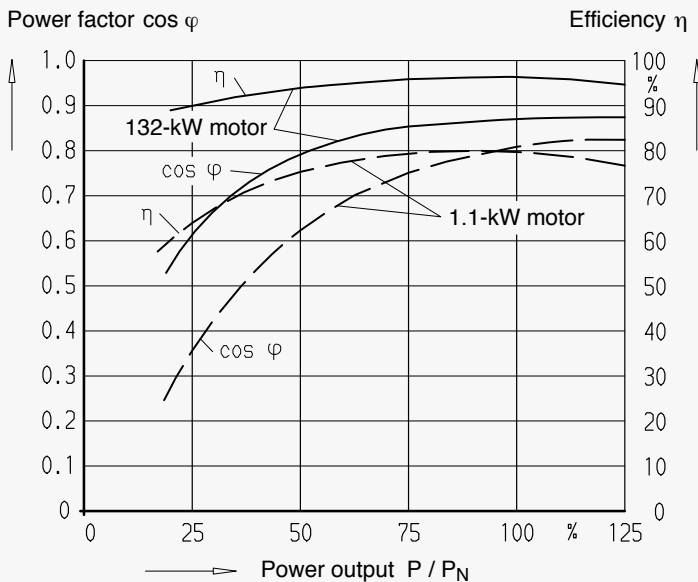



$$P_{ab} = 1.73 \cdot U \cdot I \cdot \cos \varphi \cdot \eta$$







1) P_{ab} = mechanical output power on the motor shaft
 P_{zu} = absorbed electric power

Electrical Engineering

Types of Construction and Mounting Arrangements of Rotating Electrical Machinery

Types of construction and mounting arrangements of rotating electrical machinery (Extract from DIN EN 50347)						
Machines with end shields, horizontal arrangement						
Design		Explanation				
Symbol	Figure	Bearings	Stator (Housing)	Shaft	General design	Design / Explanation Fastening or Installation
B 3		2 end shields	with feet	free shaft end	–	installation on substructure
B 5		2 end shields	without feet	free shaft end	mounting flange close to bearing, access from housing side	flanged
B 6		2 end shields	with feet	free shaft end	design B3, if necessary end shields turned through -90°	wall fastening, feet on LH side when looking at input side
B 7		2 end shields	with feet	free shaft end	design B3, if necessary end shields turned through 90°	wall fastening, feet on RH side when looking at input side
B 8		2 end shields	with feet	free shaft end	design B3, if necessary end shields turned through 180°	fastening on ceiling
B 35		2 end shields	with feet	free shaft end	mounting flange close to bearing, access from housing side	installation on substructure with additional flange

Machines with end shields, vertical arrangement						
Design		Explanation				
Symbol	Figure	Bearings	Stator (Housing)	Shaft	General design	Design / Explanation Fastening or Installation
V 1		2 end shields	without feet	free shaft end at the bottom	mounting flange close to bearing on input side, access from housing side	flanged at the bottom
V 3		2 end shields	without feet	free shaft end at the top	mounting flange close to bearing on input side, access from housing side	flanged at the top
V 5		2 end shields	with feet	free shaft end at the bottom	–	fastening to wall or on substructure
V 6		2 end shields	with feet	free shaft end at the top	–	fastening to wall or on substructure

Electrical Engineering

Types of Protection for Electrical Equipment (Protection Against Contact and Foreign Bodies)

Types of protection for electrical equipment (Extract from DIN EN 60529)					
Example of designation	<u>Type of protection</u>	<u>DIN EN 60529</u>	<u>IP</u>	<u>4</u>	<u>4</u>
Designation _____	_____	_____	_____	_____	_____
DIN number _____	_____	_____	_____	_____	_____
Code letters _____	_____	_____	_____	_____	_____
First type number _____	_____	_____	_____	_____	_____
Second type number _____	_____	_____	_____	_____	_____
An enclosure with this designation is protected against the ingress of solid foreign bodies having a diameter above 1 mm and of splashing water.					
Degrees of protection for protection against contact and foreign bodies (first type number)					
First type number	Degree of protection (Protection against contact and foreign bodies)				
0	No special protection				
1	Protection against the ingress of solid foreign bodies having a diameter above 50 mm (large foreign bodies) 1) No protection against intended access, e.g. by hand, however, protection of persons against contact with live parts				
2	Protection against the ingress of solid foreign bodies having a diameter above 12 mm (medium-sized foreign bodies) 1) Keeping away of fingers or similar objects				
3	Protection against the ingress of solid foreign bodies having a diameter above 2.5 mm (small foreign bodies) 1) 2) Keeping away tools, wires or similar objects having a thickness above 2.5 mm				
4	Protection against the ingress of solid foreign bodies having a diameter above 1 mm (grain sized foreign bodies) 1) 2) Keeping away tools, wires or similar objects having a thickness above 1 mm				
5	Protection against harmful dust covers. The ingress of dust is not entirely prevented, however, dust may not enter to such an amount that operation of the equipment is impaired (dustproof). 3) Complete protection against contact				
6	Protection against the ingress of dust (dust-tight) Complete protection against contact				
1) For equipment with degrees of protection from 1 to 4, uniformly or non-uniformly shaped foreign bodies with three dimensions perpendicular to each other and above the corresponding diameter values are prevented from ingress. 2) For degrees of protection 3 and 4, the respective expert commission is responsible for the application of this table for equipment with drain holes or cooling air slots. 3) For degree of protection 5, the respective expert commission is responsible for the application of this table for equipment with drain holes.					

Electrical Engineering

Types of Protection for Electrical Equipment (Protection Against Water)

Types of protection for electrical equipment (Extract from DIN EN 60529)					
Example of designation	<u>Type of protection</u>	<u>DIN EN 60529</u>	<u>IP</u>	<u>4</u>	<u>4</u>
Designation _____	_____	_____	_____	_____	_____
DIN number _____	_____	_____	_____	_____	_____
Code letters _____	_____	_____	_____	_____	_____
First type number _____	_____	_____	_____	_____	_____
Second type number _____	_____	_____	_____	_____	_____
An enclosure with this designation is protected against the ingress of solid foreign bodies having a diameter above 1 mm and of splashing water.					
Degrees of protection for protection against water (second type number)					
Second type number	Degree of protection (Protection against water)				
0	No special protection				
1	Protection against dripping water falling vertically. It may not have any harmful effect (dripping water).				
2	Protection against dripping water falling vertically. It may not have any harmful effect on equipment (enclosure) inclined by up to 15° relative to its normal position (diagonally falling dripping water).				
3	Protection against water falling at any angle up to 60° relative to the perpendicular. It may not have any harmful effect (spraying water).				
4	Protection against water spraying on the equipment (enclosure) from all directions. It may not have any harmful effect (splashing water).				
5	Protection against a water jet from a nozzle which is directed on the equipment (enclosure) from all directions. It may not have any harmful effect (hose-directed water).				
6	Protection against heavy sea or strong water jet. No harmful quantities of water may enter the equipment (enclosure) (flooding).				
7	Protection against water if the equipment (enclosure) is immersed under determined pressure and time conditions. No harmful quantities of water may enter the equipment (enclosure) (immersion).				
8	The equipment (enclosure) is suitable for permanent submersion under conditions to be described by the manufacturer (submersion). 1)				
1) This degree of protection is normally for air-tight enclosed equipment. For certain equipment, however, water may enter provided that it has no harmful effect.					

Table of Contents Section 8

Materials	Page
Conversion of Fatigue Strength Values of Miscellaneous Materials	62
Mechanical Properties of Quenched and Tempered Steels	63
Fatigue Strength Diagrams of Quenched and Tempered Steels	64
General-Purpose Structural Steels	65
Fatigue Strength Diagrams of General-Purpose Structural Steels	66
Case Hardening Steels	67
Fatigue Strength Diagrams of Case Hardening Steels	68
Cold Rolled Steel Strips	69
Cast Steels for General Engineering Purposes	69
Round Steel Wire for Springs	70
Lamellar Graphite Cast Iron	71
Nodular Graphite Cast Iron	71
Copper-Tin- and Copper-Zinc-Tin Casting Alloys	72
Copper-Aluminium Casting Alloys	72
Aluminium Casting Alloys	73
Lead and Tin Casting Alloys for Babbit Sleeve Bearings	74
Conversion of Hardness Values	75
Values of Solids and Liquids	76
Coefficient of Linear Expansion	77
Iron-Carbon Diagram	77
Pitting and Tooth Root Fatigue Strength Values of Steels	77
Heat Treatment During Case Hardening of Case Hardening Steels	78

Materials

Conversion of Fatigue Strength Values of Miscellaneous Materials

Conversion of fatigue strength values of miscellaneous materials								
Material	Tension ³⁾		Bending ¹⁾			Torsion ¹⁾		
	σ_W	σ_{Sch}	σ_{bW}	σ_{bSch}	σ_{bF}	τ_W	τ_{Sch}	τ_F
Structural steel	$0.45 \cdot R_m$	$1.3 \cdot \sigma_W$	$0.49 \cdot R_m$	$1.5 \cdot \sigma_{bW}$	$1.5 \cdot R_e$	$0.35 \cdot R_m$	$1.1 \cdot \tau_W$	$0.7 \cdot R_e$
Quenched and tempered steel	$0.41 \cdot R_m$	$1.7 \cdot \sigma_W$	$0.44 \cdot R_m$	$1.7 \cdot \sigma_{bW}$	$1.4 \cdot R_e$	$0.30 \cdot R_m$	$1.6 \cdot \tau_W$	$0.7 \cdot R_e$
Case hardening steel ²⁾	$0.40 \cdot R_m$	$1.6 \cdot \sigma_W$	$0.41 \cdot R_m$	$1.7 \cdot \sigma_{bW}$	$1.4 \cdot R_e$	$0.30 \cdot R_m$	$1.4 \cdot \tau_W$	$0.7 \cdot R_e$
Grey cast iron	$0.25 \cdot R_m$	$1.6 \cdot \sigma_W$	$0.37 \cdot R_m$	$1.8 \cdot \sigma_{bW}$	–	$0.36 \cdot R_m$	$1.6 \cdot \tau_W$	–
Light metal	$0.30 \cdot R_m$	–	$0.40 \cdot R_m$	–	–	$0.25 \cdot R_m$	–	–

1) For polished round section test piece of about 10 mm diameter.

2) Case-hardened; determined on round section test piece of about 30 mm diameter. R_m and R_e of core material.

3) For compression, σ_{Sch} is larger, e.g. for spring steel $\sigma_{dSch} \approx 1.3 \cdot \sigma_{Sch}$
For grey cast iron $\sigma_{dSch} \approx 3 \cdot \sigma_{Sch}$

Ultimate stress values	Type of load		
	Tension	Bending	Torsion
Tensile strength	R_m	–	–
Yield point	R_e	σ_{bF}	τ_F
Fatigue strength under alternating stresses	σ_W	σ_{bW}	τ_W
Fatigue strength under fluctuating stresses	σ_{Sch}	σ_{bSch}	τ_{Sch}

Materials
Mechanical Properties of
Quenched and Tempered Steels

Quenched and tempered steels (Extract from DIN EN 10083)											
Mechanical properties of steels in quenched and tempered condition											
Material		Diameter									
		up to 16 mm		above 16 up to 40 mm		above 40 up to 100 mm		above 100 up to 160 mm		above 160 up to 250 mm	
Symbol	Number	Yield point (0.2 Gr) N/mm ² min. R _e R _{p 0.2}	Tensile strength N/mm ² R _m	Yield point (0.2 Gr) N/mm ² min. R _e R _{p 0.2}	Tensile strength N/mm ² R _m	Yield point (0.2 Gr) N/mm ² min. R _e R _{p 0.2}	Tensile strength N/mm ² R _m	Yield point (0.2 Gr) N/mm ² min. R _e R _{p 0.2}	Tensile strength N/mm ² R _m	Yield point (0.2 Gr) N/mm ² min. R _e R _{p 0.2}	Tensile strength N/mm ² R _m
C22	1.0402	350	550– 700	300	500– 650	–	–	–	–	–	–
C35	1.0501	430	630– 780	370	600– 750	320	550– 700	–	–	–	–
C45	1.0503	500	700– 850	430	650– 800	370	630– 780	–	–	–	–
C55	1.0535	550	800– 950	500	750– 900	430	700– 850	–	–	–	–
C60	1.0601	580	850–1000	520	800– 950	450	750– 900	–	–	–	–
C22E	1.1151	350	550– 700	300	500– 650	–	–	–	–	–	–
C35E	1.1181	430	630– 780	370	600– 750	320	550– 700	–	–	–	–
C35R	1.1180	430	630– 780	370	600– 750	320	550– 700	–	–	–	–
C45E	1.1191	500	700– 850	430	650– 800	370	630– 780	–	–	–	–
C45R	1.1201	500	700– 850	430	650– 800	370	630– 780	–	–	–	–
C55E	1.1203	550	800– 950	500	750– 900	430	700– 850	–	–	–	–
C55R	1.1209	550	800– 950	500	750– 900	430	700– 850	–	–	–	–
C60E	1.1221	580	850–1000	520	800– 950	450	750– 900	–	–	–	–
C60R	1.1223	580	850–1000	520	800– 950	450	750– 900	–	–	–	–
28Mn6	1.1170	590	780– 930	490	690– 840	440	640– 790	–	–	–	–
38Cr2	1.7003	550	800– 950	450	700– 850	350	600– 750	–	–	–	–
46Cr2	1.7006	650	900–1100	550	800– 950	400	650– 800	–	–	–	–
34Cr4	1.7033	700	900–1100	590	800– 950	460	700– 850	–	–	–	–
34CrS4	1.7037	700	900–1100	590	800– 950	460	700– 850	–	–	–	–
37Cr4	1.7034	750	950–1150	630	850–1000	510	750– 900	–	–	–	–
37CrS4	1.7038	750	950–1150	630	850–1000	510	750– 900	–	–	–	–
41Cr4	1.7035	800	1000–1200	660	900–1100	560	800– 950	–	–	–	–
41CrS4	1.7039	800	1000–1200	660	900–1100	560	800– 950	–	–	–	–
25CrMo4	1.7218	700	900–1100	600	800– 950	450	700– 850	400	650– 800	–	–
34CrMo4	1.7220	800	1000–1200	650	900–1100	550	800– 950	500	750– 900	450	700– 850
34CrMoS4	1.7226	800	1000–1200	650	900–1100	550	800– 950	500	750– 900	450	700– 850
42CrMo4	1.7225	900	1100–1300	750	1000–1200	650	900–1100	550	800– 950	500	750– 900
42CrMoS4	1.7227	900	1100–1300	750	1000–1200	650	900–1100	550	800– 950	500	750– 900
50CrMo4	1.7228	900	1100–1300	780	1000–1200	700	900–1100	650	850–1000	550	800– 950
36CrNiMo4	1.6511	900	1100–1300	800	1000–1200	700	900–1100	600	800– 950	550	750– 900
34CrNiMo6	1.6582	1000	1200–1400	900	1100–1300	800	1000–1200	700	900–1100	600	800– 950
30CrNiMo8	1.6580	1050	1250–1450	1050	1250–1450	900	1100–1300	800	1000–1200	700	900–1100
51CrV4	1.8159	900	1100–1300	800	1000–1200	700	900–1100	650	850–1000	600	800– 950
30CrMoV9	1.7707	1050	1250–1450	1020	1200–1450	900	1100–1300	800	1000–1200	700	900–1100

Materials

Fatigue Strength Diagrams of Quenched and Tempered Steels

Fatigue strength diagrams of quenched and tempered steels, DIN EN 10083 (in quenched and tempered condition, test piece diameter $d = 10$ mm)

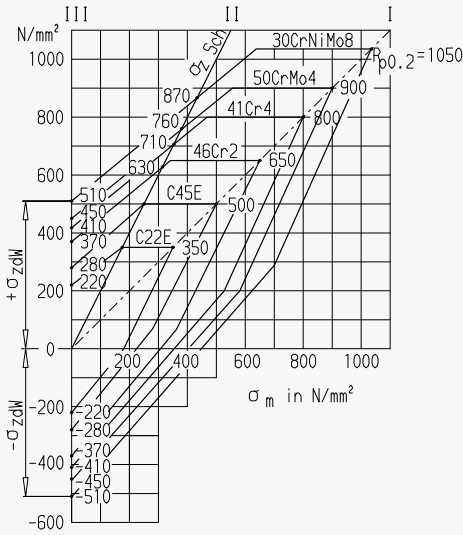

a) Tension/compression fatigue strength

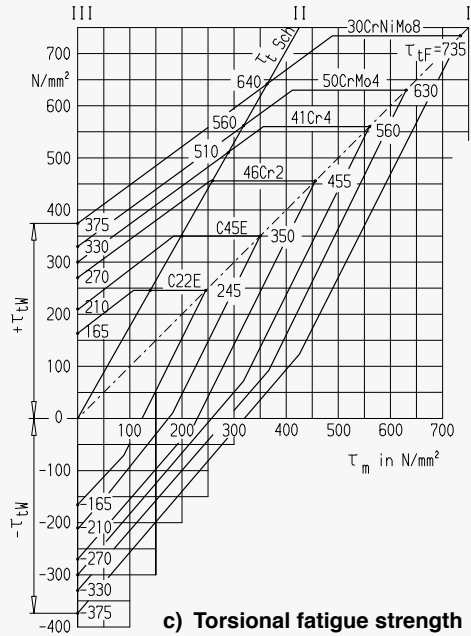

c) Torsional fatigue strength

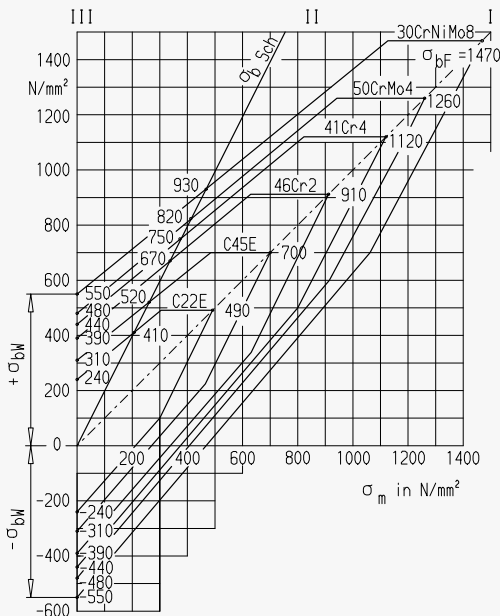

b) Bending fatigue strength

Quenched and tempered steels not illustrated may be used as follows:

- 34CrNiMo6 like 30CrNiMo8
- 30CrMoV4 like 30CrNiMo8
- 42CrMo4 like 50CrMo4
- 36CrNiMo4 like 50CrMo4
- 51CrV4 like 50CrMo4
- 34CrMo4 like 41Cr4
- 28Cr4 like 46Cr2
- C45 like C45E
- C22 like C22E

C60 and C50 lie approximately between C45E and 46Cr2.

C40, 32Cr2, C35, C30 and C25 lie approximately between C22E and C45E.

- Loading type I:** static
- Loading type II:** dynamic
- Loading type III:** alternating

Materials

General-Purpose Structural Steels

General-purpose structural steels (Extract from DIN EN 10025)												
Material			Treatment condition 1)	Tensile strength R_m in N/mm^2 for product thickness in mm			Upper yield point R_{eH} in N/mm^2 (minimum) for product thickness in mm					
Symbol (in Germany)	Num- ber	Symbol acc. to DIN EN 10025		< 3	≥ 3 ≤ 100	> 100	≤ 16	> 16 ≤ 40	> 40 ≤ 63	> 63 ≤ 80	> 80 ≤ 100	> 100
St33	1.0035	S185	U, N	310... 540	290... 510	To be agreed upon	185	175 2)	-	-	-	To be agreed upon
St37-2 USt37-2	1.0037 1.0036	S235JR S235JRG1	U, N U, N	360... 510	340... 470		235	225	215	205	195	
RSt37-2 St37-3U St37-3N	1.0038 1.0114 1.0116	S235JRG2 S235JO S235J2G3	U, N, U N				235	225	215	215	215	
St44-2 St44-3U St44-3N	1.0044 1.0143 1.0144	S275JR S275JO S275J2G3	U, N U N	430... 580	410... 560		275	265	255	245	235	
St52-3U St52-3N	1.0553 1.0570	S355JO S355J2G3	U N	510... 680	490... 630		355	345	335	325	315	
St50-2	1.0050	E295	U, N	490... 660	470... 610		295	285	275	265	255	
St60-2	1.0060	E335	U, N	590... 770	570... 710		335	325	315	305	295	
St70-2	1.0070	E360	U, N	690... 900	670... 830		365	355	345	335	325	

1) N normalized; U hot-rolled, untreated
2) This value applies to thicknesses up to 25 mm only

Materials

Fatigue Strength Diagrams of General-Purpose Structural Steels

General-Purpose Structural Steels

Fatigue strength diagrams of general-purpose structural steels, DIN EN 10025 (test piece diameter $d = 10$ mm)

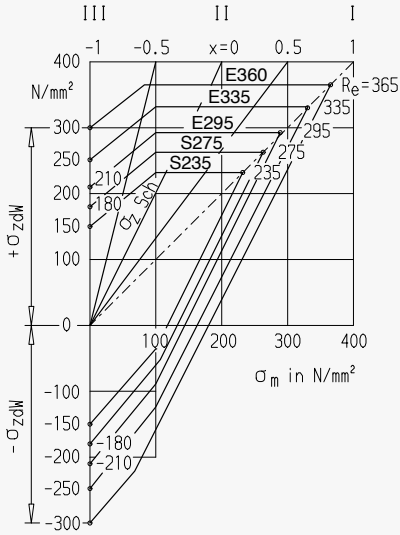

a) Tension/compression fatigue strength

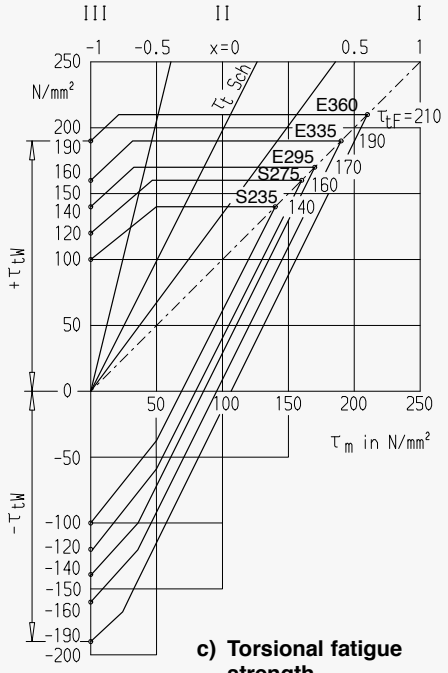

c) Torsional fatigue strength

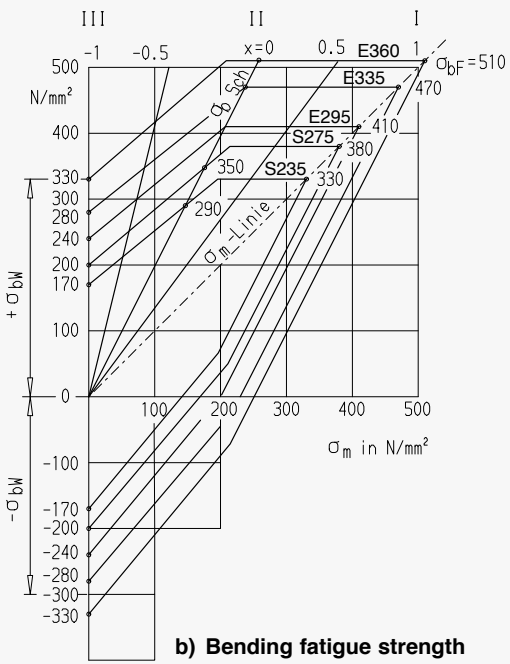

b) Bending fatigue strength

- Loading type I:** static
- Loading type II:** dynamic
- Loading type III:** alternating

Materials

Case Hardening Steels

Case hardening steels; Quality specifications (Extract from DIN EN 10084)									
Material			1) Treatment condition	For dia. 11		For dia. 30		For dia. 63	
Symbol (in Germany)	Number	Symbol acc. to DIN EN 10084		Yield point R_e N/mm ² min.	Tensile strength R_m N/mm ²	Yield point R_e N/mm ² min.	Tensile strength R_m N/mm ²	Yield point R_e N/mm ² min.	Tensile strength R_m N/mm ²
C10	1.0301	C10	For details, see DIN EN 10084	390	640– 790	295	490– 640	–	–
Ck10	1.1121	C10E		390	640– 790	295	490– 640	–	–
C15	1.0401	C15		440	740– 890	355	590– 790	–	–
Ck15	1.1141	C15E		440	740– 890	355	590– 790	–	–
Cm15	1.1140	C15R		440	740– 890	355	590– 790	–	–
15Cr13	1.7015	15Cr13		510	780–1030	440	690– 890	–	–
16MnCr5	1.7131	16MnCr5		635	880–1180	590	780–1080	440	640– 940
16MnCrS5	1.7139	16MnCrS5		635	880–1180	590	780–1080	440	640– 940
20MnCr5	1.7147	20MnCr5		735	1080–1380	685	980–1280	540	780–1080
20MnCrS5	1.7149	20MnCrS5		735	1080–1380	685	980–1280	540	780–1080
20MoCr4	1.7321	20MoCr4		635	880–1180	590	780–1080	–	–
20MoCrS4	1.7323	20MoCrS4		635	880–1180	590	780–1080	–	–
25MoCrS4	1.7325	25MoCrS4		735	1080–1380	685	980–1280	–	–
15CrNi6	1.5919	15CrNi6		685	960–1280	635	880–1180	540	780–1080
18CrNi8	1.5920	18CrNi8		835	1230–1480	785	1180–1430	685	1080–1330
17CrNiMo6	1.6587	18CrNiMo7-6		835	1180–1430	785	1080–1330	685	980–1280
1) Dependent on treatment, the Brinell hardness is different.									
Treatment condition			Meaning						
C			treated for shearing load						
G			soft annealed						
BF			treated for strength						
BG			treated for ferrite/pearlite structure						

Materials

Fatigue Strength Diagrams of Case Hardening Steels

**Fatigue strength diagrams of case hardening steels, DIN EN 10084
(Core strength after case hardening, test piece diameter $d = 10\text{ mm}$)**

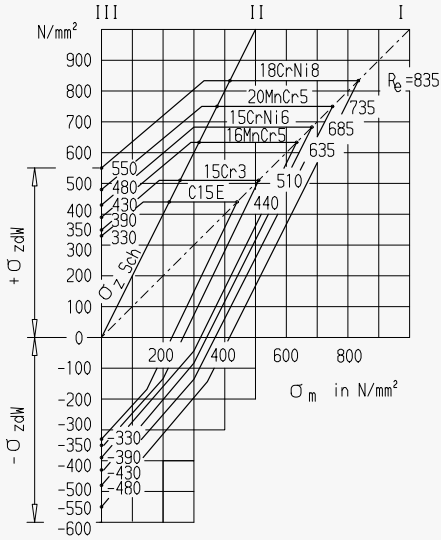

a) Tension/compression fatigue strength

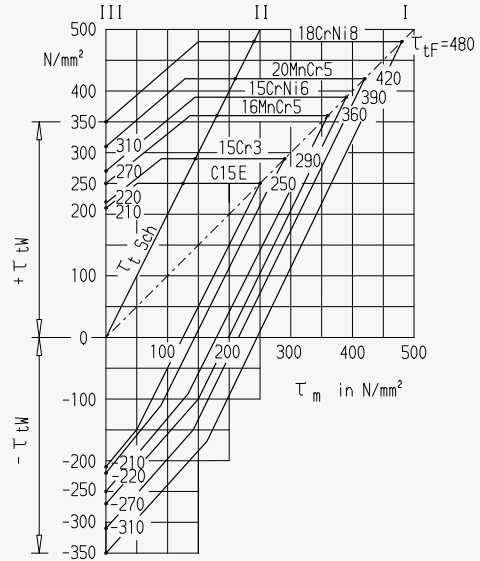

c) Torsional fatigue strength

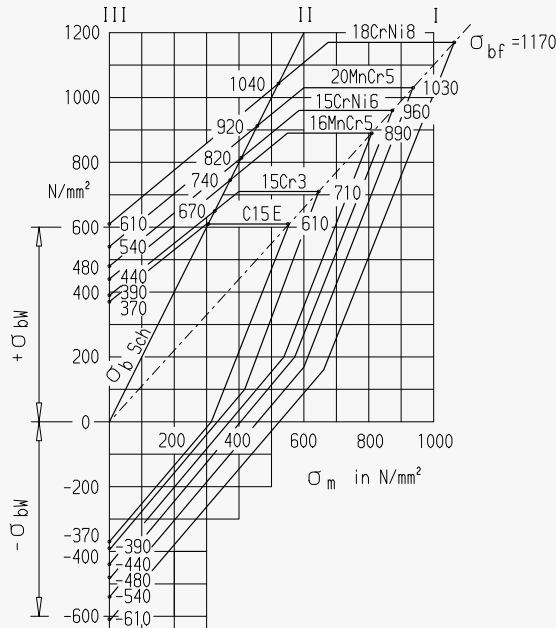

b) Bending fatigue strength

Case hardening steels not illustrated may be used as follows:

- 25MoCr4 like 20MnCr5
- 17CrNiMo6 like 18CrNi8

- Loading type I:** static
- Loading type II:** dynamic
- Loading type III:** alternating

Materials

Cold Rolled Steel Strips

Cast Steels for General Engineering Purposes

Cold rolled steel strips (Extract from DIN EN 10132)			
Symbol (in Germany)	Material		Tensile strength R_m ¹⁾ N/mm ² maximum
	Number	Symbol acc. to DIN EN 10132	
C55 Ck55	1.0535 1.1203	C55 C55E	610
C60 Ck60	1.0601 1.1221	C60 C60E	620
C67 Ck67	1.0603 1.1231	C67 C67S	640
C75 Ck75	1.0605 1.1248	C75 C75S	640
Ck85 Ck101	1.1269 1.1274	C85S C100S	670 690
71Si7	1.5029	71Si7	800
67SiCr5	1.7103	67SiCr5	800
50CrV4	1.8159	50CrV4	740

1) R_m for cold rolled and soft-annealed condition; for strip thicknesses up to 3 mm

Cast steels for general engineering purposes (Extract from DIN 1681)					
Material		Yield point $R_e, R_{p0.2}$ N/mm ² min.	Tensile strength R_m N/mm ² min.	Notched bar impact work (ISO-V-notch specimens) A_v ≤ 30 mm > 30 mm Mean value ¹⁾ J min.	
Symbol	Number				
GS-38 (GE200)	1.0420	200	380	35	35
GS-45 (GE240)	1.0446	230	450	27	27
GS-52 (GE260)	1.0552	260	520	27	22
GS-60 (GE300)	1.0558	300	600	27	20

The mechanical properties apply to specimens which are taken from test pieces with thicknesses up to 100 mm. Furthermore, the yield point values also apply to the casting itself, in so far as the wall thickness is ≤ 100 mm.

1) Determined from three individual values each.

Materials

Round Steel Wire for Springs

Round steel wire for springs (Extract from DIN EN 10218)				
Diameter of wire mm	Grade of wire			
	A	B	C	D
	Tensile strength R_m in N/mm ²			
0.07	–	–	–	2800 – 3100
0.3	–	2370 – 2650	–	2660 – 2940
1	1720 – 1970	1980 – 2220	–	2230 – 2470
2	1520 – 1750	1760 – 1970	1980 – 2200	1980 – 2200
3	1410 – 1620	1630 – 1830	1840 – 2040	1840 – 2040
4	1320 – 1520	1530 – 1730	1740 – 1930	1740 – 1930
5	1260 – 1450	1460 – 1650	1660 – 1840	1660 – 1840
6	1210 – 1390	1400 – 1580	1590 – 1770	1590 – 1770
7	1160 – 1340	1350 – 1530	1540 – 1710	1540 – 1710
8	1120 – 1300	1310 – 1480	1490 – 1660	1490 – 1660
9	1090 – 1260	1270 – 1440	1450 – 1610	1450 – 1610
10	1060 – 1230	1240 – 1400	1410 – 1570	1410 – 1570
11	–	1210 – 1370	1380 – 1530	1380 – 1530
12	–	1180 – 1340	1350 – 1500	1350 – 1500
13	–	1160 – 1310	1320 – 1470	1320 – 1470
14	–	1130 – 1280	1290 – 1440	1290 – 1440
15	–	1110 – 1260	1270 – 1410	1270 – 1410
16	–	1090 – 1230	1240 – 1390	1240 – 1390
17	–	1070 – 1210	1220 – 1360	1220 – 1360
18	–	1050 – 1190	1200 – 1340	1200 – 1340
19	–	1030 – 1170	1180 – 1320	1180 – 1320
20	–	1020 – 1150	1160 – 1300	1160 – 1300

Materials

Lamellar Graphite Cast Iron

Nodular Graphite Cast Iron

Lamellar graphite cast iron (Extract from DIN EN 1561)							
Material			Wall thicknesses in mm		Tensile strength ¹⁾ R _m	Brinell hardness 1) HB 30	Compressive strength ²⁾ σ _{dB}
Symbol	Number	Symbol acc. to DIN 1691	above	up to	N/mm ²		N/mm ²
EN-GJL-100	EN-JL1010	GG-10	5	40	min. 100 ²⁾	–	–
EN-GJL-150	EN-JL1020	GG-15	10	20	130	225	600
			20	40	110	205	
			40	80	95	–	
			80	150	80	–	
EN-GJL-200	EN-JL1030	GG-20	10	20	180	250	720
			20	40	155	235	
			40	80	130	–	
			80	150	115	–	
EN-GJL-250	EN-JL1040	GG-25	10	20	225	265	840
			20	40	195	250	
			40	80	170	–	
			80	150	155	–	
EN-GJL-300	EN-JL1050	GG-30	10	20	270	285	960
			20	40	240	265	
			40	80	210	–	
			80	150	195	–	
EN-GJL-350	EN-JL1060	GG-35	10	20	315	285	1080
			20	40	280	275	
			40	80	250	–	
			80	150	225	–	

The values apply to castings which are made in sand moulds or moulds with comparable heat diffusibility.

1) These values are reference values.

2) Values in the separately cast test piece with 30 mm diameter of the unfinished casting.

Nodular graphite cast iron (Extract from DIN EN 1563)						
Properties in cast-on test pieces						
Material			Wall thickness of casting	Thickness of cast-on test piece	Tensile strength R _m	0.2% proof stress R _{p0.2}
Symbol	Number	Symbol acc. to DIN 1693	mm	mm	N/mm ²	N/mm ²
EN-GJS-400-18U-LT	EN-JS1049	GGG-40.3	from 30 up to 60 above 60 up to 200	40 70	390 370	250 240
EN-GJS-400-15U	EN-JS1072	GGG-40	from 30 up to 60 above 60 up to 200	40 70	390 370	250 240
EN-GJS-500-7U	EN-JS1082	GGG-50	from 30 up to 60 above 60 up to 200	40 70	450 420	300 290
EN-GJS-600-3U	EN-JS1092	GGG-60	from 30 up to 60 above 60 up to 200	40 70	600 550	360 340
EN-GJS-700-2U	EN-JS1102	GGG-70	from 30 up to 60 above 60 up to 200	40 70	700 650	400 380

Materials

Copper-Tin and Copper-Zinc-Tin Casting Alloys

Copper-Aluminium Casting Alloys

Copper-tin and copper-zinc-tin casting alloys (Extract from DIN EN 1982)						
Material			Condition on delivery	0.2% proof stress ¹⁾ R _{p0.2} min. in N/mm ²	Tensile strength ¹⁾ R _m min. in N/mm ²	
Symbol	Number	Symbol acc. to DIN 1705				
CuSn12-C-GS CuSn12-C-GZ CuSn12-C-GC	CC483K	G-CuSn12 GZ-CuSn12 GC-CuSn12	Sand-mould cast iron Centrifugally cast iron Continuously cast iron	140 150 140	260 280 280	
CuSn12Ni-C-GS CuSn12Ni-C-GZ CuSn12Ni-C-GC		CC484K	G-CuSn12Ni GZ-CuSn12Ni GC-CuSn12Ni	Sand-mould cast iron Centrifugally cast iron Continuously cast iron	160 180 170	280 300 300
CuSn12Pb2-C-GS CuSn12Pb2-C-GZ CuSn12Pb2-C-GC			CC482K	G-CuSn12Pb GZ-CuSn12Pb GC-CuSn12Pb	Sand-mould cast iron Centrifugally cast iron Continuously cast iron	140 150 140
CuSn10-Cu-GS	CC480K			G-CuSn10	Sand-mould cast iron	130
CuSn7Zn4Pb7-C-GS CuSn7Zn4Pb7-C-GZ CuSn7Zn4Pb7-C-GC	CC493K	G-CuSn7ZnPb GZ-CuSn7ZnPb GC-CuSn7ZnPb		Sand-mould cast iron Centrifugally cast iron Continuously cast iron	120 130 120	240 270 270
CuSn7Zn2Pb3-C-GS		CC492K	G-CuSn6ZnNi	Sand-mould cast iron	140	270
CuSn5Zn5Pb5-C-GS		CC491K	G-CuSn5ZnPb	Sand-mould cast iron	90	220
CuSn3Zn8Pb5-C-GS	CC490K	G-CuSn2ZnPb	Sand-mould cast iron	90	210	

1) Material properties in the test bar

Copper-aluminium casting alloys (Extract from DIN EN 1982)						
Material			Condition on delivery	0.2% proof stress ¹⁾ R _{p0.2} min. in N/mm ²	Tensile strength ¹⁾ R _m min. in N/mm ²	
Symbol	Number	Symbol acc. to DIN 1714				
CuAl10Fe2-C-GS CuAl10Fe2-C-GM CuAl10Fe2-C-GZ	CC331G	G-CuAl10Fe GK-CuAl10Fe GZ-CuAl10Fe	Sand-mould cast iron Chilled casting Centrifugally cast iron	180 200 200	500 550 550	
CuAl10Ni3Fe2-C-GS CuAl10Ni3Fe2-C-GK CuAl10Ni3Fe2-C-GZ		CC332G	G-CuAl9Ni GK-CuAl9Ni GZ-CuAl9Ni	Sand-mould cast iron Chilled casting Centrifugally cast iron	200 230 250	500 530 600
CuAl10Fe5Ni5-C-GS CuAl10Fe5Ni5-C-GM CuAl10Fe5Ni5-C-GZ CuAl10Fe5Ni5-C-GC			CC333G	G-CuAl10Ni GK-CuAl10Ni GZ-CuAl10Ni GC-CuAl10Ni	Sand-mould cast iron Chilled casting Centrifugally cast iron Continuously cast iron	270 300 300 300
CuAl11Fe6Ni6-C-GS CuAl11Fe6Ni6-C-GM CuAl11Fe6Ni6-C-GZ	CC334G			G-CuAl11Ni GK-CuAl11Ni GZ-CuAl11Ni	Sand-mould cast iron Chilled casting Centrifugally cast iron	320 400 400

1) Material properties in the test bar

Materials

Aluminium Casting Alloys

Aluminium casting alloys (Extract from DIN EN 1706)				
Material			0.2% proof stress $R_{p0.2}$	Tensile strength R_m
Symbol	Number	Symbol acc. to DIN 1725-2	in N/mm ²	in N/mm ²
AC-AlCu4MgTi	AC-21000	G-AlCu4TiMg	200 up to 220	300 up to 320
AC-AlCu4Ti	AC-21100	G-AlCu4Ti	180 up to 220	280 up to 330
AC-AlSi7Mg	AC-42100	G-AlSi7Mg	180 up to 210	230 up to 290
AC-AlSi10Mg(a)	AC-43000	G-AlSi10Mg	80 up to 220	150 up to 240
AC-AlSi10Mg(Cu)	AC-43200	G-AlSi10Mg(Cu)	80 up to 200	160 up to 240
AC-AlSi9Mg	AC-43300	G-AlSi9Mg	180 up to 210	230 up to 290
AC-AlSi10Mg(Fe)	AC-43400	G-AlSi10Mg	140	240
AC-AlSi11	AC-44000	G-AlSi11	70 up to 80	150 up to 170
AC-AlSi12(a)	AC-44200	G-AlSi12	70 up to 80	150 up to 170
AC-AlSi12(Fe)	AC-44300	GD-AlSi12	130	240
AC-AlSi6Cu4	AC-45000	G-AlSi6Cu4	90 up to 100	150 up to 170
AC-AlSi9Cu3(Fe)	AC-46000	GD-AlSi9Cu3	140	240
AC-AlSi8Cu3	AC-46200	G-AlSi9Cu3	90 up to 140	150 up to 240
AC-AlSi12(Cu)	AC-47000	G-AlSi12(Cu)	80 up to 90	150 up to 170
AC-AlSi12Cu1(Fe)	AC-47100	GD-AlSi12(Cu)	140	240
AC-AlMg3(a)	AC-51100	G-AlMg3	70	140 up to 150
AC-AlMg9	AC-51200	GD-AlMg9	130	200
AC-AlMg5	AC-51300	G-AlMg5	90 up to 100	160 up to 180
AC-AlMg5(Si)	AC-51400	G-AlMg5Si	100 up to 110	160 up to 180

Materials

Lead and Tin Casting Alloys for Babbit Sleeve Bearings

Lead and tin casting alloys for babbitt sleeve bearings (Extract from DIN ISO 4381)							
Material		Brinell hardness ¹⁾ HB 10/250/180			0.2% proof stress ¹⁾ R _{p 0.2} in N/mm ²		
Symbol	Number	20 °C	50 °C	120 °C	20 °C	50 °C	100 °C
PbSb15SnAs	2.3390	18	15	14	39	37	25
PbSb15Sn10	2.3391	21	16	14	43	32	30
PbSb14Sn9CuAs	2.3392	22	22	16	46	39	27
PbSb10Sn6	2.3393	16	16	14	39	32	27
SnSb12Cu6Pb	2.3790	25	20	12	61	60	36
SnSb8Cu4	2.3791	22	17	11	47	44	27
SnSb8Cu4Cd	2.3792	28	25	19	62	44	30

1) Material properties in the test bar

Materials

Conversion of Hardness Values (DIN EN ISO 18265)

Tensile strength N/mm ²	Vickers hardness (F _{≥98N})	Brinell hardness 2) $\left(0.102 \cdot \frac{F}{D^2} = 30 \frac{N}{\text{mm}^2}\right)$	Rockwell hardness				Tensile strength N/mm ²	Vickers hardness (F _{≥98N})	Brinell hardness 2) $\left(0.102 \cdot \frac{F}{D^2} = 30 \frac{N}{\text{mm}^2}\right)$	Rockwell hardness		
			HRB	HRC	HRA	HRD ₁₎				HRC	HRA	HRD ₁₎
255	80	76.0					1155	360	342	36.6	68.7	52.8
270	85	80.7	41.0				1190	370	352	37.7	69.2	53.6
285	90	85.5	48.0				1220	380	361	38.8	69.8	54.4
305	95	90.2	52.0				1255	390	371	39.8	70.3	55.3
320	100	95.0	56.2				1290	400	380	40.8	70.8	56.0
335	105	99.8					1320	410	390	41.8	71.4	56.8
350	110	105	62.3				1350	420	399	42.7	71.8	57.5
370	115	109					1385	430	409	43.6	72.3	58.2
385	120	114	66.7				1420	440	418	44.5	72.8	58.8
400	125	119					1455	450	428	45.3	73.3	59.4
415	130	124	71.2				1485	460	437	46.1	73.6	60.1
430	135	128					1520	470	447	46.9	74.1	60.7
450	140	133	75.0				1555	480	(456)	47.7	74.5	61.3
465	145	138					1595	490	(466)	48.4	74.9	61.6
480	150	143	78.7				1630	500	(475)	49.1	75.3	62.2
495	155	147					1665	510	(485)	49.8	75.7	62.9
510	160	152	81.7				1700	520	(494)	50.5	76.1	63.5
530	165	156					1740	530	(504)	51.1	76.4	63.9
545	170	162	85.0				1775	540	(513)	51.7	76.7	64.5
560	175	166					1810	550	(523)	52.3	77.0	64.8
575	180	171	87.1				1845	560	(532)	53.0	77.4	65.4
595	185	176					1880	570	(542)	53.6	77.8	65.8
610	190	181	89.5				1920	580	(551)	54.1	78.0	66.2
625	195	185					1955	590	(561)	54.7	78.4	66.7
640	200	190	91.5				1995	600	(570)	55.2	78.6	67.0
660	205	195	92.5				2030	610	(580)	55.7	78.9	67.5
675	210	199	93.5				2070	620	(589)	56.3	79.2	67.9
690	215	204	94.0				2105	630	(599)	56.8	79.5	68.3
705	220	209	95.0				2145	640	(608)	57.3	79.8	68.7
720	225	214	96.0				2180	650	(618)	57.8	80.0	69.0
740	230	219	96.7					660		58.3	80.3	69.4
755	235	223						670		58.8	80.6	69.8
770	240	228	98.1	20.3	60.7	40.3		680		59.2	80.8	70.1
785	245	233		21.3	61.2	41.1		690		59.7	81.1	70.5
800	250	238	99.5	22.2	61.6	41.7		700		60.1	81.3	70.8
820	255	242		23.1	62.0	42.2		720		61.0	81.8	71.5
835	260	247	(101)	24.0	62.4	43.1		740		61.8	82.2	72.1
850	265	252		24.8	62.7	43.7		760		62.5	82.6	72.6
865	270	257	(102)	25.6	63.1	44.3		780		63.3	83.0	73.3
880	275	261		26.4	63.5	44.9		800		64.0	83.4	73.8
900	280	266	(104)	27.1	63.8	45.3		820		64.7	83.8	74.3
915	285	271		27.8	64.2	46.0		840		65.3	84.1	74.8
930	290	276	(105)	28.5	64.5	46.5		860		65.9	84.4	75.3
950	295	280		29.2	64.8	47.1		880		66.4	84.7	75.7
965	300	285		29.8	65.2	47.5		900		67.0	85.0	76.1
995	310	295		31.0	65.8	48.4		920		67.5	85.3	76.5
1030	320	304		32.3	66.4	49.4		940		68.0	85.6	76.9
1060	330	314		33.3	67.0	50.2						
1095	340	323		34.4	67.6	51.1						
1125	350	333		35.5	68.1	51.9						

The figures in brackets are hardness values outside the domain of definition of standard hardness test methods which, however, in practice are frequently used as approximate values. Furthermore, the Brinell hardness values in brackets apply only if the test was carried out with a carbide ball.

1) Internationally usual, e.g. ASTM E 18-74 (American Society for Testing and Materials)

2) Calculated from HB = 0.95 HV (Vickers hardness)

Determination of Rockwell hardness HRA, HRB, HRC, and HRD acc. to DIN EN 10109 Part 1

Determination of Vickers hardness acc. to DIN 50133 Part 1

Determination of Brinell hardness acc. to DIN EN 10003 Part 1

Determination of tensile strength acc. to DIN EN 10002 Part 1 and Part 5

Materials

Coefficient of Linear Expansion;

Iron-Carbon Diagram;

Fatigue Strength Values for Gear Materials

Coefficient of linear expansion α
The coefficient of linear expansion α gives the fractional expansion of the unit of length of a substance per 1 degree K rise in temperature. For the linear expansion of a body applies: $\Delta l = l_0 \cdot \alpha \cdot \Delta T$ where Δl : change of length l_0 : original length α : coefficient of linear expansion ΔT : rise of temperature

Coefficients of linear expansion of some substances at 0 ... 100 °C	
Substance	α [$10^{-6}/K$]
Aluminium alloys	21 ... 24
Grey cast iron (e.g. GG-20, GG-25)	10.5
Steel, plain and low-alloy	11.5
Steel, stainless (18CrNi8)	16
Steel, rapid machining steel	11.5
Copper	17
Brass CuZn37	18.5
Bronze CuSn8	17.5

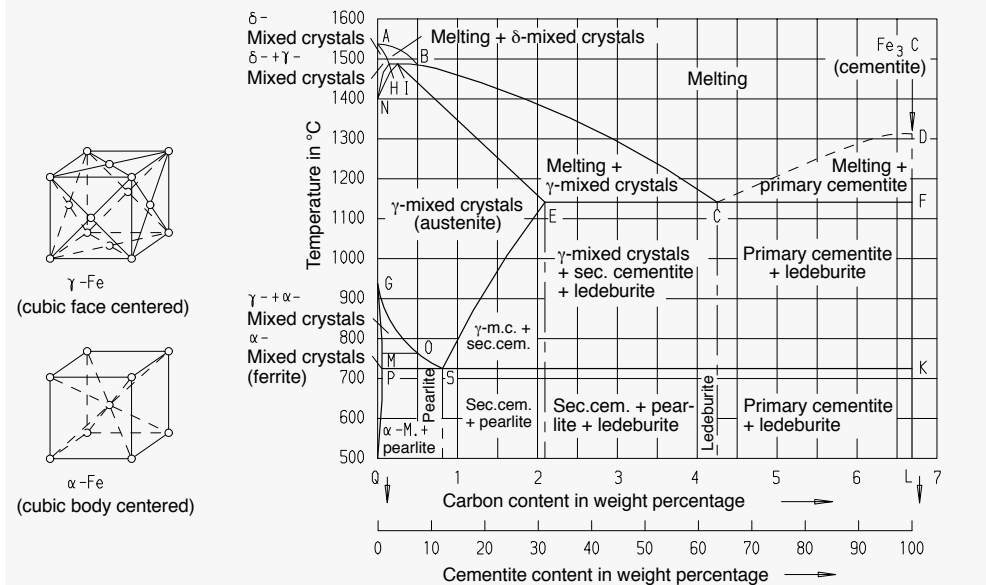

Iron-carbon diagram



Pitting and tooth root fatigue strength of steels				
Grade of steel	Material symbol	Hardness on finished gear HV1	σ_{Hlim} N/mm ²	σ_{Flim} N/mm ²
Case hardening steels, case-hardened	16MnCr5	720	1470	430
	20MnCr5	680	1470	430
	18CrNiMo7-6	740	1500	500
Quenched and tempered steels, quenched and tempered	30CrNiMo8	290	730	300
	34CrNiMo6	310	770	310
	42CrMo4	280	740	305
Quenched and tempered steels, nitrided	34CrNiMo6	630	1000	370
	42CrMo4	600	1000	370

Materials

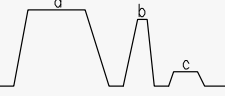
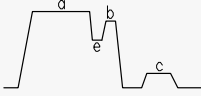
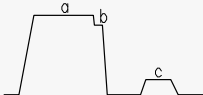
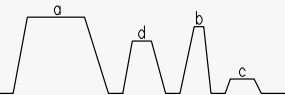
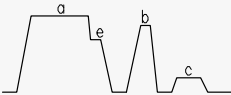
Heat Treatment During Case Hardening of Case Hardening Steels

Heat treatment during case hardening of case hardening steels acc. to DIN EN 10084		
Usual heat treatment during case hardening		
A. Direct hardening or double hardening	B. Single hardening	C. Hardening after isothermal transformation
		
Direct hardening from carburizing temperature	Single hardening from core or case hardening temperature	Hardening after isothermal transformation in the pearlite stage (e)
		
Direct hardening after lowering to hardening temperature	Single hardening after intermediate annealing (soft annealing) (d)	Hardening after isothermal transformation in the pearlite stage (e) and cooling-down to room temperature
	<p>a carburizing temperature b hardening temperature c tempering temperature d intermediate annealing (soft annealing) temperature e transformation temperature in the pearlite stage</p>	
Double hardening		

Usual case hardening temperatures						
Material		a	b		c	
Symbol	Number	Carburizing temperature ¹⁾ °C	Core hardening temperature ²⁾ °C	Case hardening temperature ²⁾ °C	Quenchant	
					Tempering °C	
C10 C10E C15	1.0301 1.1121 1.0401	880 up to 980	880 up to 920	780 up to 820	With regard to the properties of the component, the selection of the quenchant depends on the hardenability or case-hardenability of the steel, the shape and cross section of the work piece to be hardened, as well as on the effect of the quenchant.	150 up to 200
15Cr3 17Cr3 16MnCr5 16MnCrS5 20MnCr5 20MnCrS5 20MoCr4 20MoCrS4 20NiCrMo2-2 20NiCrMoS2-2	1.7015 1.7016 1.7131 1.7139 1.7147 1.7149 1.7321 1.7323 1.6523 1.6526					
15CrNi6 18CrNiMo7-6	1.5919 1.6587		830 up to 870			

- 1) Decisive criteria for the determination of the carburizing temperature are mainly the required time of carburizing, the chosen carburizing agent, and the plant available, the provided course of process, as well as the required structural constitution. For direct hardening, carburizing usually is carried out at temperatures below 950 °C. In special cases, carburizing temperatures up to above 1000 °C are applied.
- 2) In case of direct hardening, quenching is carried out either from the carburizing temperature or any lower temperature. In particular if there is a risk of warping, lower hardening temperatures are preferred.

Table of Contents Section 9

Lubricating Oils	Page
Viscosity-Temperature-Diagram for Mineral Oils	80
Viscosity-Temperature-Diagram for Synthetic Oils of Poly- α -Olefine Base	81
Viscosity-Temperature-Diagram for Synthetic Oils of Polyglycole Base	82
Kinematic Viscosity and Dynamic Viscosity	83
Viscosity Table for Mineral Oils	84

Lubricating Oils

Viscosity-Temperature-Diagram for Mineral Oils

Viscosity-temperature-diagram for mineral oils

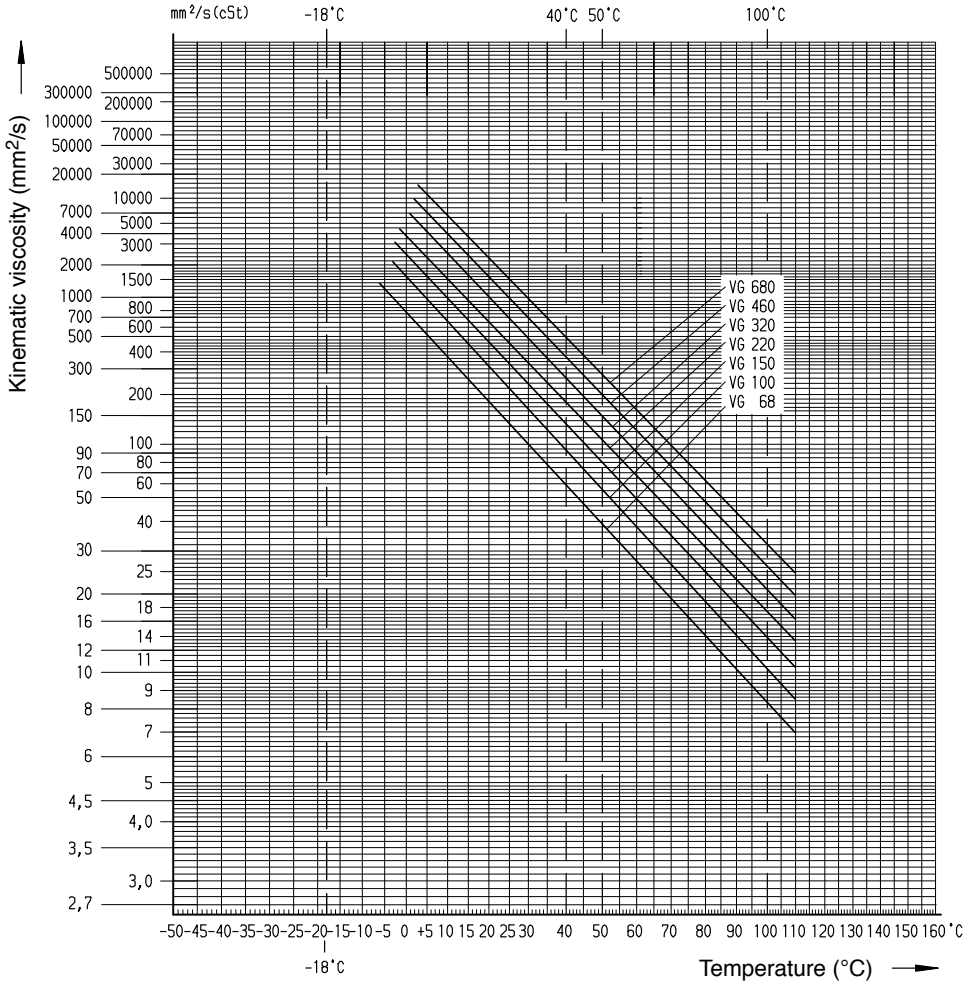

Lubricating Oils

Viscosity-Temperature-Diagram for Synthetic Oils of Poly- α -Olefine Base

Viscosity-temperature-diagram for synthetic oils of poly- α -olefine base

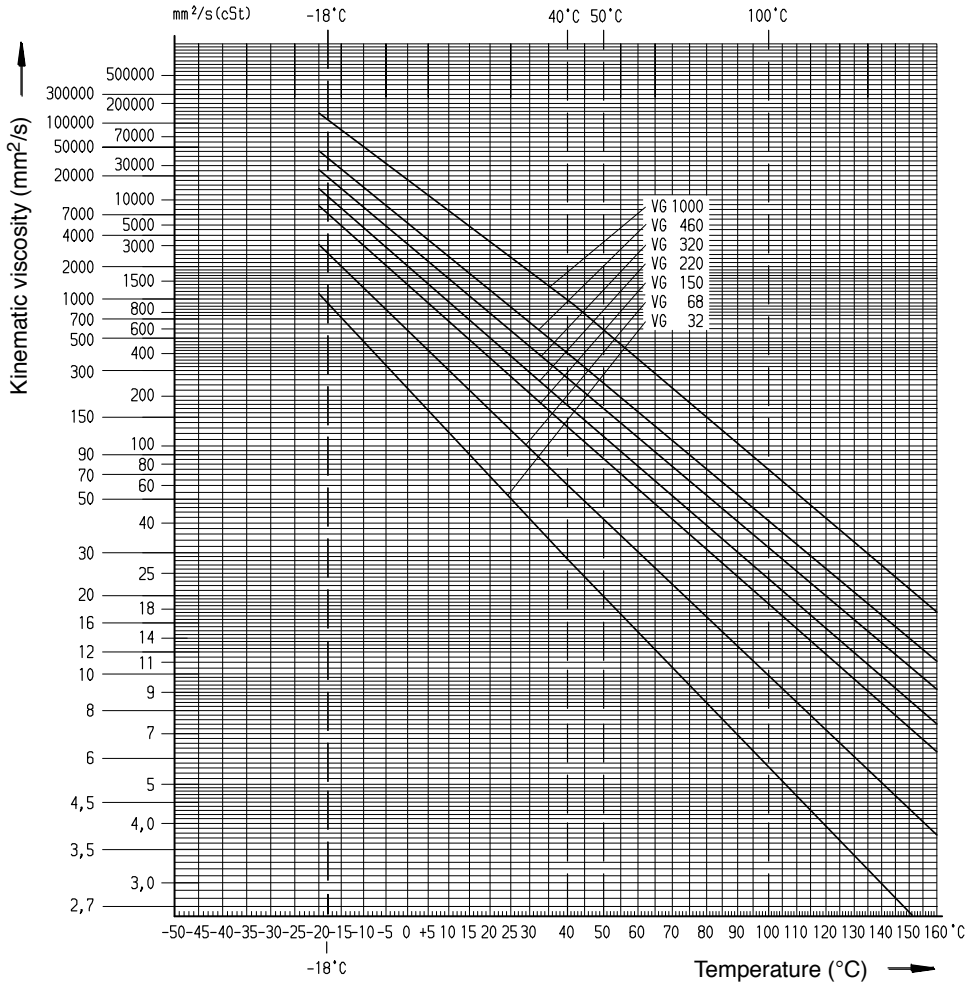

Lubricating Oils
 Viscosity-Temperature-Diagram for
 Synthetic Oils of Polyglycole Base

Viscosity-temperature-diagram for synthetic oils of polyglycole base

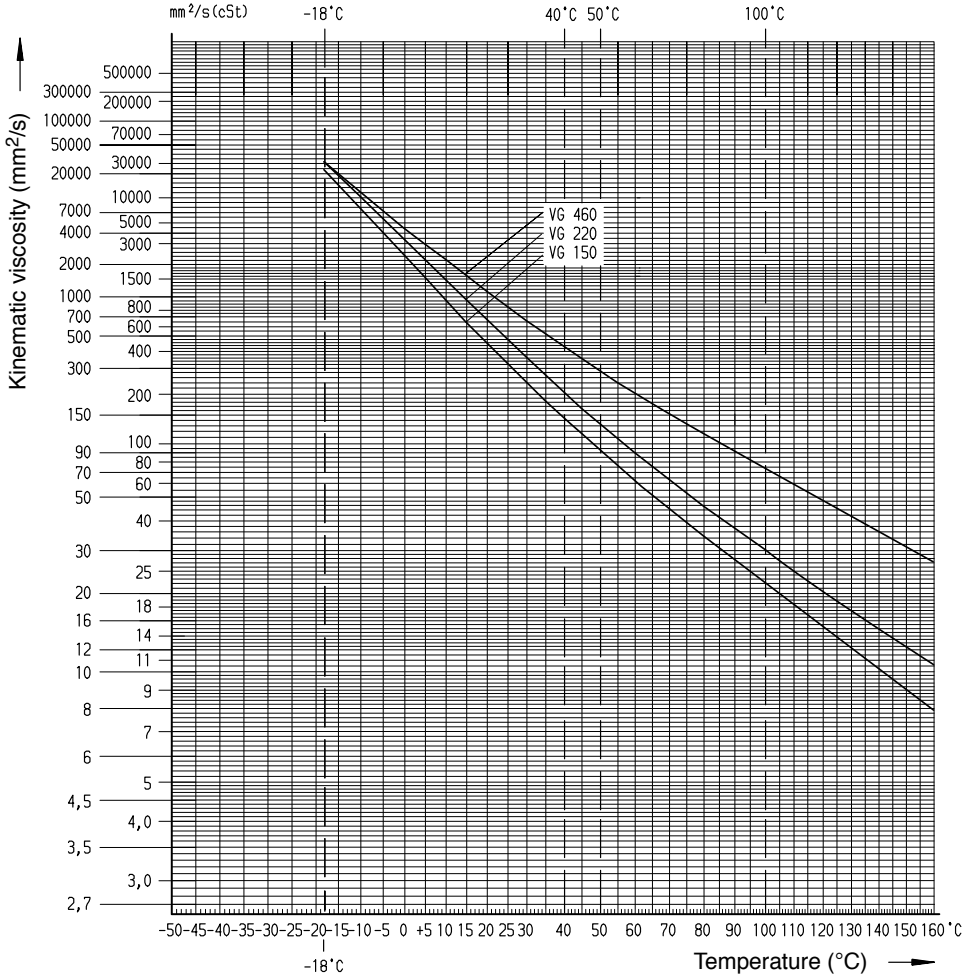

Lubricating Oils

Kinematic Viscosity and Dynamic Viscosity for Mineral Oils at any Temperature

Kinematic viscosity ν		
Quantities for the determination of the kinematic viscosity		
VG grade	W_{40} [-]	m [-]
32	0.18066	3.7664
46	0.22278	3.7231
68	0.26424	3.6214
100	0.30178	3.5562
150	0.33813	3.4610
220	0.36990	3.4020
320	0.39900	3.3201
460	0.42540	3.3151
680	0.45225	3.2958
1000	0.47717	3.2143
1500	0.50192	3.1775

$W = m (2.49575 - \lg T) + W_{40} \quad (1)$	
$\nu = 10^{10W} - 0.8 \quad (2)$	

m [-]: slope
 T [K]: thermodynamic temperature ¹⁾
 W_{40} [-]: auxiliary quantity at 40 °C
 W [-]: auxiliary quantity
 ν [cSt]: kinematic viscosity

1) $T = t + 273.15$ [K]

Dynamic viscosity η	
$\eta = \nu \cdot \varrho \cdot 0.001 \quad (3)$	
$\varrho = \varrho_{15} - (t - 15) \cdot 0.0007 \quad (4)$	

t [°C]: temperature
 ϱ_{15} [kg/dm³]: density at 15 °C
 ϱ [kg/dm³]: density
 ν [cSt]: kinematic viscosity
 η [Ns/m²]: dynamic viscosity

Density ϱ_{15} in kg/dm ³ of lubricating oils for gear units ²⁾ (Example)							
VG grade	68	100	150	220	320	460	680
ARAL Degol BG Plus	–	0.888	0.892	0.897	0.895	0.902	0.905
MOBIL Mobilgear 600 XP	0.880	0.880	0.890	0.890	0.900	0.900	0.910
MOBIL Mobilgear XMP	–	0.890	0.896	0.900	0.903	0.909	0.917
CASTROL Optigear BM	0.890	0.893	0.897	0.905	0.915	0.920	0.930
CASTROL Tribol 1100	0.888	0.892	0.897	0.904	0.908	0.916	0.923

2) Mineral base gear oils in accordance with designation CLP as per DIN 51517 Part 3. These oils comply with the minimum requirements as specified in DIN 51517 Part 3. They are suitable for operating temperatures from -10 °C up to +90 °C (briefly +100 °C).

Lubricating Oils

Viscosity Table for Mineral Oils

ISO-VG DIN 51519	Approx. assignment to previous DIN 51502	Mean viscosity (40 °C) and approx. viscosities in mm ² /s (cSt) at					Saybolt universal seconds (SSU) at 40 °C (mean value) 1)	AGMA lubricant N° at 40 °C 1)	Approx. assignment to	
		20 °C	40 °C	50 °C		100 °C			motor oils	motor- car gear oils
		cSt	cSt	cSt	Engler	cSt			SAE	SAE
5	2	8 (1.7 E)	4.6	4	1.3	1.5				
7	4	12 (2 E)	6.8	5	1.4	2.0				
10	9	21 (3 E)	10	8	1.7	2.5				
15	–	34	15	11	1.9	3.5			5 W	
22	16	55	22	15	2.3	4.5			10 W	70 W 75 W
32		88	32	21	3	5.5				
46	25	137	46	30	4	6.5	214	1 EP	15 W 20 W 20	80 W
68	36	219	68	43	6	8.5	316	2.2 EP		
100	49	345	100	61	8	11	464	3.3 EP	30	85 W
	68									
150	92	550	150	90	12	15	696	4.4 EP	40	
220	114	865	220	125	16	19	1020	5.5 EP	50	90
	144									
320	169	1340	320	180	24	24	1484	6.6 EP		140
460	225	2060	460	250	33	30	2132	7 EP		
680	324	3270	680	360	47	40	3152	8 EP		
1000		5170	1000	510	67	50				250
1500		8400	1500	740	98	65				

1) Approximate comparative value to ISO VG grades

Table of Contents Section 10

Cylindrical Gear Units	Page
Symbols and Units	86 + 87
General Introduction	88
Geometry of Involute Gears	
Concepts and Parameters Associated With Involute Teeth	88
Standard Basic Rack Tooth Profile	88
Module	89
Tool Reference Profile	89
Generating Tooth Flanks	90
Concepts and Parameters Associated With Cylindrical Gears	91
Geometric Definitions	91
Pitches	91
Addendum Modification	92
Concepts and Parameters Associated With a Cylindrical Gear Pair	93
Terms	93
Mating Quantities	93
Contact Ratios	94
Summary of the Most Important Formulae	95 – 97
Gear Teeth Modifications	98 + 99
Load Carrying Capacity of Involute Gears	
Scope of Application and Purpose	99 + 100
Basic Details	100 + 101
General Factors	102
Application Factor	102
Dynamic Factor	102
Face Load Factor	102
Transverse Load Factor	102
Tooth Flank Load Carrying Capacity	103
Effective Hertzian Pressure	103
Permissible Hertzian Pressure	103 + 104
Tooth Root Load Carrying Capacity	104
Effective Tooth Root Stress	104 – 106
Permissible Tooth Root Stress	106
Safety Factors	106
Calculation Example	106 + 107
Gear Unit Types	
Standard Designs	107
Load Sharing Gear Units	107
Comparisons	107 + 108
Load Value	108
Referred Torques	109 + 110
Efficiencies	110
Example	110
Noise Emitted by Gear Units	
Definitions	111 + 112
Measurements	112
Determination via Sound Pressure	112 + 113
Determination via Sound Intensity	113
Prediction	113 + 114
Possibilities of Influencing	114

Cylindrical Gear Units

Symbols and Units for Cylindrical Gear Units

a	mm	Centre distance	n	min ⁻¹	Speed
a _d	mm	Reference centre distance	p	N/mm ²	Pressure; compression
b	mm	Facewidth	p	mm	Pitch on the reference circle
c _p	mm	Bottom clearance between standard basic rack tooth profile and counter profile	p _{bt}	mm	Pitch on the base circle
d	mm	Reference diameter	p _e	mm	Normal base pitch
d _a	mm	Tip diameter	p _{en}	mm	Normal base pitch at a point
d _b	mm	Base diameter	p _{et}	mm	Normal transverse pitch
d _f	mm	Root diameter	p _{ex}	mm	Axial pitch
d _w	mm	Pitch diameter	p _t	mm	Transverse base pitch; reference circle pitch
e	mm	Spacewidth on the reference cylinder	p _{rP0}	mm	Protuberance value on the tool's standard basic rack tooth profile
e _p	mm	Spacewidth on the standard basic rack tooth profile	q	mm	Machining allowance on the cylindrical gear tooth flanks
f	Hz	Frequency	r	mm	Reference circle radius; radius
g _α	mm	Length of path of contact	r _a	mm	Tip radius
h	mm	Tooth depth	r _b	mm	Base radius
h _a	mm	Addendum	r _w	mm	Radius of the working pitch circle
h _{aP}	mm	Addendum of the standard basic rack tooth profile	s	mm	Tooth thickness on the reference circle
h _{aP0}	mm	Addendum of the tool's standard basic rack tooth profile	s _{an}	mm	Tooth thickness on the tip circle
h _f	mm	Dedendum	s _p	mm	Tooth thickness of the standard basic rack tooth profile
h _{fP}	mm	Dedendum of the standard basic rack tooth profile	s _{P0}	mm	Tooth thickness of the tool's standard basic rack tooth profile
h _{fP0}	mm	Dedendum of the tool's standard basic rack tooth profile	u	–	Gear ratio
h _p	mm	Tooth depth of the standard basic rack tooth profile	v	m/s	Circumferential speed on the reference circle
h _{p0}	mm	Tooth depth of the tool's standard basic rack tooth profile	w	N/mm	Line load
h _{prP0}	mm	Protuberance height of the tool's standard basic rack tooth profile	x	–	Addendum modification coefficient
h _{wP}	mm	Working depth of the standard basic rack tooth profile and the counter profile	x _E	–	Generating addendum modification coefficient
k	–	Addendum modification factor	z	–	Number of teeth
m	mm	Module			
m _n	mm	Normal module	A	m ²	Gear teeth surface
m _t	mm	Transverse module	A _s	mm	Tooth thickness deviation
			B _L	N/mm ²	Load value

Cylindrical Gear Units

Symbols and Units for Cylindrical Gear Units

D	mm	Construction dimension	Z_X	-	Size factor
F_n	N	Load	α	Degree	Transverse pressure angle at a point; pressure angle
F_t	N	Nominal peripheral force at the reference circle	$\hat{\alpha}$	rad	Angle α in the circular measure ($\hat{\alpha} = \alpha \cdot \pi / 180$)
G	N	Weight	α_{at}	Degree	Transverse pressure angle at the tip circle
HV1	-	Vickers hardness at $F = 9.81$ N	α_n	Degree	Normal pressure angle
K_A	-	Application factor	α_p	Degree	Pressure angle at a point of the standard basic rack tooth profile
$K_{F\alpha}$	-	Transverse load factor (for tooth root stress)	α_{p0}	Degree	Pressure angle at a point of the tool's standard basic rack tooth profile
$K_{F\beta}$	-	Face load factor (for tooth root stress)	α_{prp0}	Degree	Protuberance pressure angle at a point
$K_{H\alpha}$	-	Transverse load factor (for contact stress)	α_t	Degree	Transverse pressure angle at the reference circle
$K_{H\beta}$	-	Face load factor (for contact stress)	α_{wt}	Degree	Working transverse pressure angle at the pitch circle
K_v	-	Dynamic factor	β	Degree	Helix angle at the reference circle
L_{pA}	dB	Sound pressure level, A-weighted	β_b	Degree	Base helix angle
L_{WA}	dB	Sound power level, A-weighted	ε_α	-	Transverse contact ratio
P	kW	Nominal power rating of driven machine	ε_β	-	Overlap ratio
R_Z	μm	Mean peak-to-valley height	ε_γ	-	Total contact ratio
S_F	-	Factor of safety from tooth breakage	ζ	Degree	Working angle of the involute
S_H	-	Factor of safety from pitting	η	-	Efficiency
S	m^2	Enveloping surface	ϱ	mm	Radius of curvature
T	Nm	Torque	ϱ_{aP0}	mm	Tip radius of curvature of the tool's standard basic rack tooth profile
Y_β	-	Helix angle factor	ϱ_{fP0}	mm	Root radius of curvature of the tool's standard basic rack tooth profile
Y_ε	-	Contact ratio factor	σ_H	N/mm^2	Effective Hertzian pressure
Y_{FS}	-	Tip factor	σ_{Hlim}	N/mm^2	Allowable stress number for contact stress
Y_R	-	Roughness factor	σ_{HP}	N/mm^2	Allowable Hertzian pressure
Y_X	-	Size factor	σ_F	N/mm^2	Effective tooth root stress
Z_β	-	Helix angle factor	σ_{Flim}	N/mm^2	Bending stress number
Z_ε	-	Contact ratio factor	σ_{FP}	N/mm^2	Allowable tooth root stress
Z_H	-	Zone factor	ν_{40}	mm^2/s	Lubricating oil viscosity at 40 °C
Z_L	-	Lubricant factor			
Z_v	-	Speed factor			

Note: The unit rad (= radian) may be replaced by 1.

1. Cylindrical gear units

1.1 Introduction

In the industry, mainly gear units with case hardened and fine-machined gears are used for torque and speed adaptation of prime movers and driven machines. After carburising and hardening, the tooth flanks are fine-machined by grinding (or removing material by means of shaping or generating tools coated with mechanically resistant material). In comparison with other gear units, which, for example, have quenched and tempered or nitrided gears, gear units with case hardened gears have higher power capacities, i.e. they require less space for the same speeds and torques. Further, gear units have the best efficiencies. Motion is transmitted without slip at constant speed. As a rule, an infinitely variable change-speed gear unit with primary or secondary gear stages presents the most economical solution even in case of variable speed control.

In industrial gear units mainly involute gears are used. Compared with other tooth profiles, the technical and economical advantages are basically:

- Simple manufacture with straight-sided flanked tools;
- The same tool for all numbers of teeth;
- Generating different tooth profiles and centre distances with the same number of teeth by means of the same tool by addendum modification;
- Uniform transmission of motion even in case of centre distance errors from the nominal value;
- The direction of the normal force of teeth remains constant during meshing;
- Advanced stage of development;
- Good availability on the market.

When load sharing gear units are used, output torques can be doubled or tripled in comparison

with gear units without load sharing. Load sharing gear units mostly have one input and one output shaft. Inside the gear unit the load is distributed and then brought together again on the output shaft gear. The uniform sharing of the load between the individual branches is achieved by special design measures.

1.2 Geometry of involute gears

The most important concepts and parameters associated with cylindrical gears and cylindrical gear pairs with involute teeth in accordance with DIN 3960 are represented in sections 1.2.1 to 1.2.4. /1/

1.2.1 Concepts and parameters associated with involute teeth

1.2.1.1 Standard basic rack tooth profile

The standard basic rack tooth profile is the normal section through the teeth of the basic rack which is produced from an external gear tooth system with an infinitely large diameter and an infinitely large number of teeth. From figure 1 follows:

- The flanks of the standard basic rack tooth profile are straight lines and are located symmetrically below the pressure angle at a point α_p to the tooth centre line;
- Between module m and pitch p the relation is $p = \pi m$;
- The nominal dimensions of tooth thickness and spacewidth on the datum line are equal, i.e. $s_p = e_p = p/2$;
- The bottom clearance c_p between basic rack tooth profile and counter profile is 0.1 m up to 0.4 m ;
- The addendum is fixed by $h_{aP} = m$, the dedendum by $h_{fP} = m + c_p$ and thus, the tooth depth by $h_p = 2 m + c_p$;
- The working depth of basic rack tooth profile and counter profile is $h_{wP} = 2 m$.

10

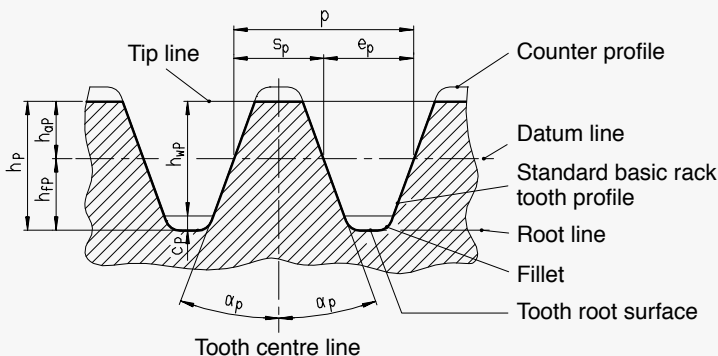

Figure 1 Basic rack tooth profiles for involute teeth of cylindrical gears (acc. to DIN 867)

Cylindrical Gear Units

Geometry of Involute Gears

1.2.1.2 Module

The module m of the standard basic rack tooth profile is the module in the normal section m_n of the gear teeth. For a helical gear with helix angle β on the reference circle, the transverse

module in a transverse section is $m_t = m_n / \cos\beta$. For a spur gear $\beta = 0$ and the module is $m = m_n = m_t$. In order to limit the number of the required gear cutting tools, module m has been standardized in preferred series 1 and 2, see table 1.

Series 1	1	1.25	1.5	2	2.5	3	4	5	6	8	10	12	16	20	25	32
Series 2	1.75				3.5		4.5	7		9	14		18	22	28	

1.2.1.3 Tool reference profile

The tool reference profile according to figure 2a is the counter profile of the standard basic rack tooth profile according to figure 1. For industrial gear units, the pressure angle at a point of the tool reference profile $\alpha_{p0} = \alpha_P$ is 20° , as a rule. The tooth thickness s_{p0} of the tool on the tool datum line depends on the stage of machining. The pre-machining tool leaves on both flanks of the teeth a machining allowance q for finish-machining. Therefore, the tooth thickness for pre-machining tools is $s_{p0} < p/2$, and for finish-machining tools $s_{p0} = p/2$.

The pre-machining tool generates the root diameter and the fillet on a cylindrical gear. The finish-machining tool removes the machining allowance on the flanks, however, normally it does not touch the root circle – like on the tooth profile in figure 3a.

Between pre- and finish-machining, cylindrical gears are subjected to a heat treatment which, as a rule, leads to warping of the teeth and growing of the root and tip circles.

Especially for cylindrical gears with a relatively large number of teeth or a small module there is a risk of generating a notch in the root on finish-machining. To avoid this, pre-machining tools are provided with protuberance flanks as shown in figure 2b. They generate a root undercut on the gear, see figure 3b. On the tool, protuberance value pr_{p0} , protuberance pressure angle at a point α_{prp0} , as well as the tip radius of curvature q_{ap0} must be so dimensioned that the active tooth profile on the gear will not be reduced and the tooth root will not be weakened too much.

On cylindrical gears with small modules one often accepts on purpose a notch in the root if its distance to the root circle is large enough and thus the tooth root load carrying capacity is not impaired by a notch effect, figure 3c. In order to prevent the tip circle of the mating gear from touching the fillet it is necessary that a check for meshing interferences is carried out on the gear pair. /1/

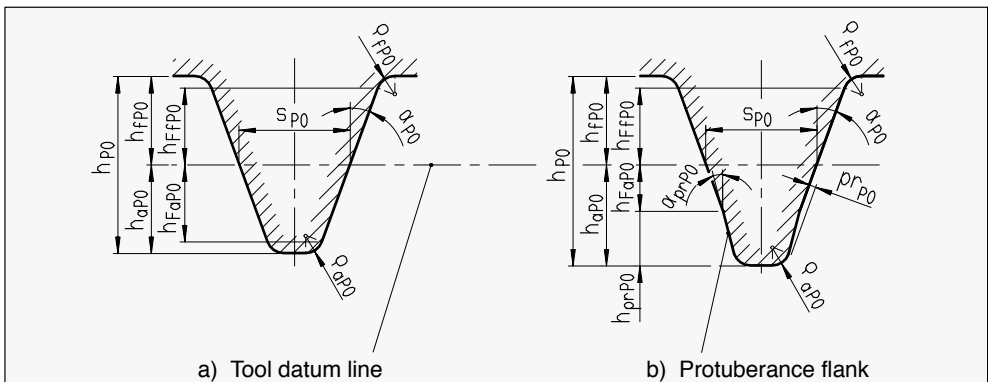
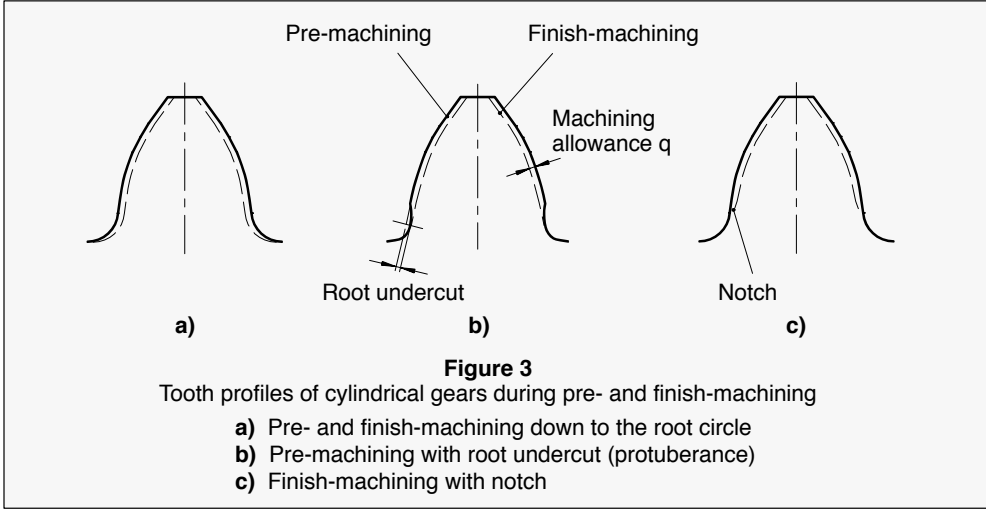

Figure 2
Reference profiles of gear cutting tools for involute teeth of cylindrical gears
a) For pre-machining and finish-machining
b) For pre-machining with root undercut (protuberance)

Cylindrical Gear Units

Geometry of Involute Gears



1.2.1.4 Generating tooth flanks

With the development of the envelope, an envelope line of the base cylinder with the base diameter d_b generates the involute surface of a spur gear.

A straight line inclined by a base helix angle β_b to the envelope line in the developed envelope is the generator of an involute surface (involute helicoid) of a helical gear, figure 4.

The involute which is always lying in a transverse section, figure 5, is described by the transverse

pressure angle at a point α and radius r in the equations

$$\text{inv}\alpha = \tan\alpha - \hat{\alpha} \tag{1}$$

$$r = r_b / \cos\alpha \tag{2}$$

$r_b = d_b/2$ is the base radius. The angle $\text{inv}\alpha$ is termed involute function, and the angle

$$\zeta = \hat{\alpha} + \text{inv}\alpha = \tan\alpha$$

$\tan\alpha$ is termed working angle.

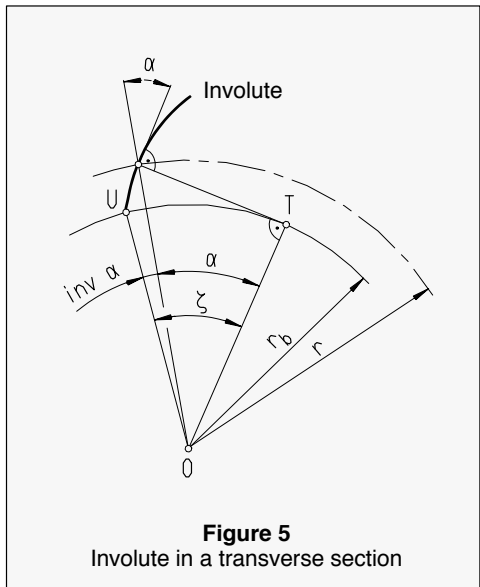
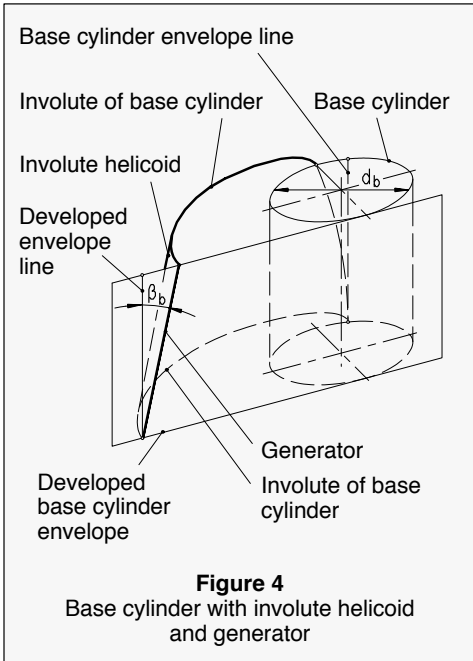

Cylindrical Gear Units

Geometry of Involute Gears

1.2.2 Concepts and parameters associated with cylindrical gears

1.2.2.1 Geometric definitions

In figure 6 the most important geometric quantities of a cylindrical gear are shown.

The reference circle is the intersection of the reference cylinder with a plane of transverse section. When generating tooth flanks, the straight pitch line of the tool rolls off at the reference circle. Therefore, the reference circle periphery corresponds to the product of pitch p and number of teeth z , i.e. $\pi \cdot d = p \cdot z$. Since $m_t = p/\pi$, the equation for the reference diameter thus is $d = m_t \cdot z$. Many geometric quantities of the cylindrical gear are referred to the reference circle.

For a helical gear, at the point of intersection of the involute with the reference circle, the trans-

verse pressure angle at a point α in the transverse section is termed transverse pressure angle α_t , see figures 5 and 7. If a tangent line is put against the involute surface in the normal section at the point of intersection with the reference circle, the corresponding angle is termed normal pressure angle α_n ; this is equal to the pressure angle α_{P0} of the tool. The interrelationship with the helix angle β at the reference circle is $\tan \alpha_n = \cos \beta \cdot \tan \alpha_t$. On a spur gear $\alpha_n = \alpha_t$.

Between the base helix angle β_b and the helix angle β on the reference circle the relationship is $\sin \beta_b = \cos \alpha_n \cdot \sin \beta$. The base diameter d_b is given by the reference diameter d , by $d_b = d \cdot \cos \alpha_t$.

In the case of internal gears, the number of teeth z and thus also the diameters d , d_b , d_a , d_f are negative values.

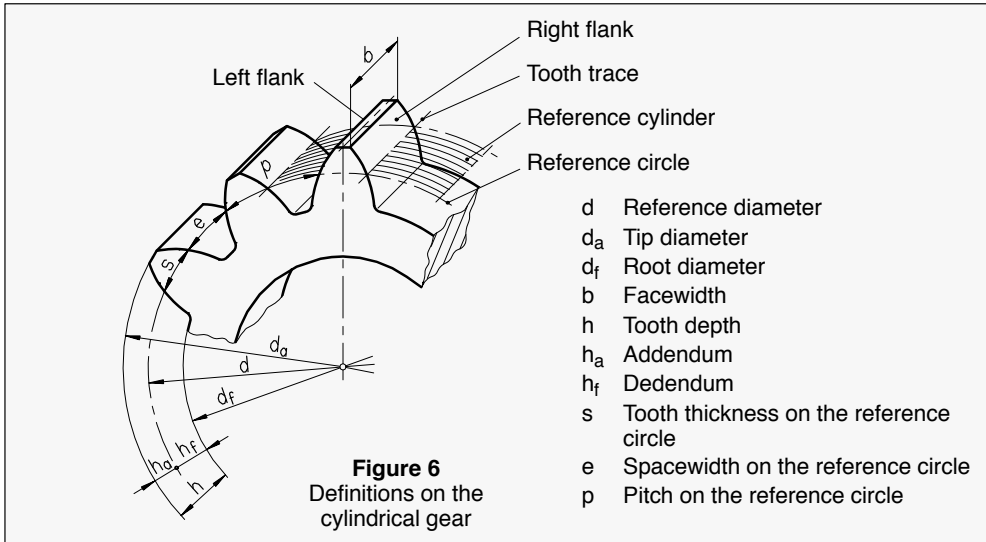

1.2.2.2 Pitches

The pitch p_t of a helical gear (p in the case of a spur gear) lying in a transverse section is the length of the reference circle arc between two successive right or left flanks, see figures 6 and 7. With the number of teeth z results $p_t = \pi \cdot d / z = \pi \cdot m_t$.

The normal transverse pitch p_{et} of a helical gear is equal to the pitch on the basic circle p_{bt} , thus $p_{et} = p_{bt} = \pi \cdot d_b / z$. Hence, in the normal section the normal base pitch at a point $p_{en} = p_{et} / \cos \beta_b$ is resulting from it, and in the axial section the axial pitch $p_{ex} = p_{et} / \tan \beta_b$, see figure 13.

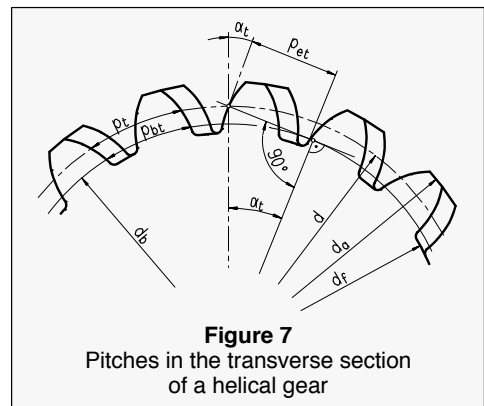

1.2.2.3 Addendum modification

When generating tooth flanks on a cylindrical gear by means of a tooth-rack-like tool (e.g. a hob), a straight pitch line parallel to the datum line of tool rolls off on the reference circle. The distance ($x \cdot m_n$) between the straight pitch line and the datum line of tool is the addendum modification, and x is the addendum modification coefficient, see figure 8.

An addendum modification is positive, if the datum line of tool is displaced from the reference circle towards the tip, and it is negative if the datum line is displaced towards the root of the gear. This is true for both external and internal gears. In the case of internal gears the tip points to the inside. An addendum modification for external gears should be carried through approximately within the limits as shown in figure 9.

The addendum modification limits x_{min} and x_{max} are represented dependent on the virtual number of teeth $z_n = z / (\cos\beta \cdot \cos^2\beta_b)$. The upper limit x_{max} takes into account the intersection circle of the teeth and applies to a normal crest width in the normal section of $s_{an} = 0.25 m_n$. When falling below the lower limit x_{min} this results in an undercut which shortens the usable involute and weakens the tooth root.

A positive addendum modification results in a greater tooth root width and thus in an increase in the tooth root carrying capacity. In the case of small numbers of teeth this has a considerably stronger effect than in the case of larger ones. One mostly strives for a greater addendum modification on pinions than on gears in order to achieve equal tooth root carrying capacities for both gears, see figure 19.

Further criteria for the determination of addendum modification are contained in /2/, /3/, and /4/. The addendum modification coefficient x refers to gear teeth free of backlash and deviations. In order to take into account tooth thickness deviation A_s (for backlash and manufacturing tolerances) and machining allowances q (for pre-machining), one has to give the following generating addendum modification coefficient for the manufacture of a cylindrical gear:

$$x_E = x + \frac{A_s}{2m_n \cdot \tan \alpha_n} + \frac{q}{m_n \cdot \sin \alpha_n} \quad (3)$$

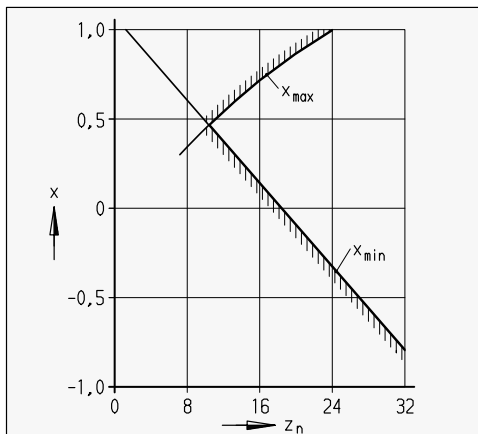
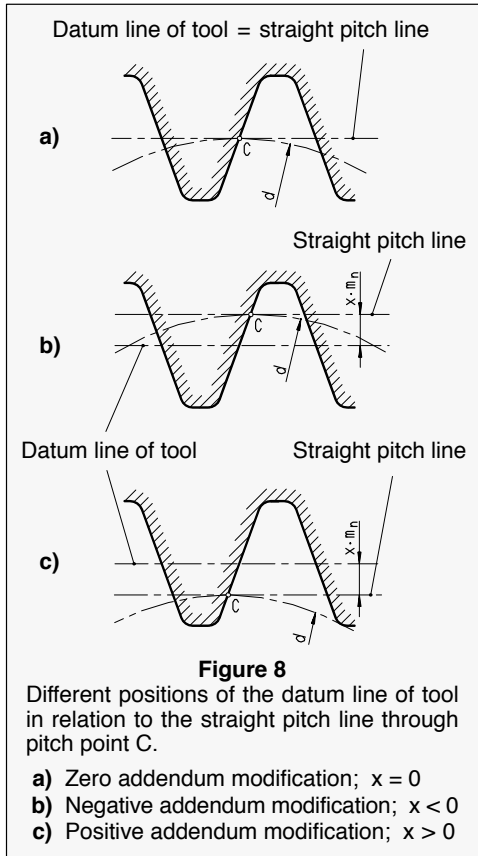

10

Cylindrical Gear Units

Geometry of Involute Gears

1.2.3 Concepts and parameters associated with a cylindrical gear pair

1.2.3.1 Terms

The mating of two external cylindrical gears (external gears) gives an external gear pair. In the case of a helical external gear pair one gear has left-handed and the other one right-handed flank direction.

The mating of an external cylindrical gear with an internal cylindrical gear (internal gear) gives an internal gear pair. In the case of a helical internal gear pair, both gears have the same flank direction, that is either right-handed or left-handed. The subscript 1 is used for the size of the smaller gear (pinion), and the subscript 2 for the larger gear (wheel or internal gear).

In the case of an unmodified gear pair (a zero gear pair), both gears have as addendum modification coefficient $x_1 = x_2 = 0$ (zero gears).

In the case of a gear pair at reference centre distance, both gears have addendum modifications (modified gears), that is with $x_1 + x_2 = 0$, i.e. $x_1 = -x_2$.

For a modified gear pair, the sum is not equal to zero, i.e. $x_1 + x_2 \neq 0$. One of the cylindrical gears in this case may, however, have an addendum modification $x = 0$.

1.2.3.2 Mating quantities

The gear ratio of a gear pair is the ratio of the number of teeth of the gear z_2 to the number of teeth of the pinion z_1 , thus $u = z_2 / z_1$. Working pitch circles with diameter $d_w = 2 \cdot r_w$ are those transverse intersection circles of a cylindrical gear pair, which have the same circumferential speed at their mutual contact point (pitch point C), figure 10. The working pitch circles divide the centre distance $a = r_{w1} + r_{w2}$ in the ratio of the tooth numbers, thus $d_{w1} = 2 \cdot a / (u + 1)$ and $d_{w2} = 2 \cdot a \cdot u / (u + 1)$.

In the case of both an unmodified gear pair and a gear pair at reference centre distance, the centre distance is equal to the zero centre distance $a_d = (d_1 + d_2) / 2$, and the pitch circles are simultaneously the reference circles, i.e. $d_w = d$. However, in the case of a modified gear pair, the centre distance is not equal to the zero centre distance, and the pitch circles are not simultaneously the reference circles.

If in the case of modified gear pairs the bottom clearance c_p corresponding to the standard basic rack tooth profile is to be retained (which is not absolutely necessary), then an addendum modification is to be carried out. The addendum modification factor is $k = (a - a_d) / m_n - (x_1 + x_2)$. For unmodified gear pairs and gear pairs at reference centre distance, $k = 0$. In the case of external gear pairs $k < 0$, i.e. the tip diameters of both gears become smaller. In the case of

internal gear pairs $k > 0$, i.e. the tip diameters of both gears become larger (on an internal gear with negative tip diameter the absolute value becomes smaller).

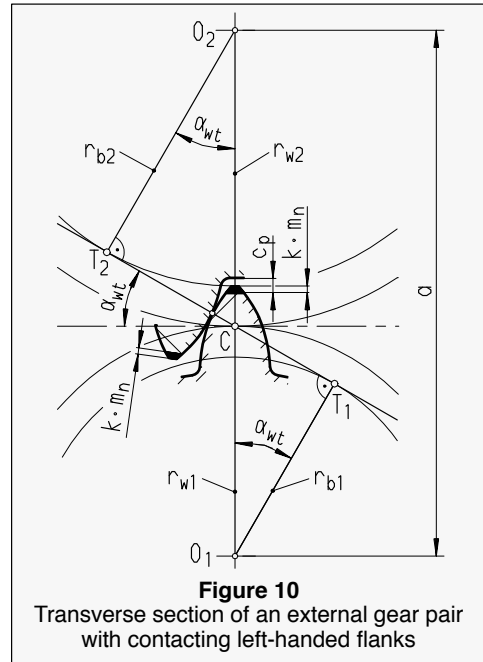

Figure 10
Transverse section of an external gear pair with contacting left-handed flanks

In a cylindrical gear pair either the left or the right flanks of the teeth contact each other on the line of action. Changing the flanks results in a line of action each lying symmetrical in relation to the centre line through $O_1 O_2$. The line of action with contacting left flanks in figure 10 is the tangent to the two base circles at points T_1 and T_2 . With the common tangent on the pitch circles it includes the working pressure angle α_{wt} .

The working pressure angle α_{wt} is the transverse pressure angle at a point belonging to the working pitch circle. According to figure 10 it is determined by $\cos \alpha_{wt} = d_{b1} / d_{w1} = d_{b2} / d_{w2}$. In the case of unmodified gear pairs and gear pairs at reference centre distance, the working pressure angle is equal to the transverse pressure angle on the reference circle, i.e. $\alpha_{wt} = \alpha_t$.

The length of path of contact g_α is that part of the line of action which is limited by the two tip circles of the cylindrical gears, figure 11.

The starting point A of the length of path of contact is the point at which the line of action intersects the tip circle of the driven gear, and the finishing point E is the point at which the line of action intersects the tip circle of the driving gear.

Cylindrical Gear Units

Geometry of Involute Gears

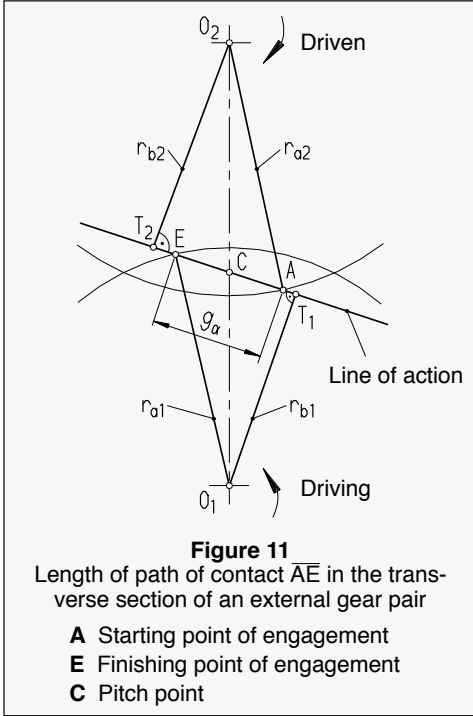

1.2.3.3 Contact ratios

The transverse contact ratio ϵ_α in the transverse section is the ratio of the length of path of contact g_α to the normal transverse pitch p_{et} , i.e. $\epsilon_\alpha = g_\alpha / p_{et}$, see figure 12.

In the case of spur gear pairs, the transverse contact ratio gives the average number of pairs of teeth meshing during the time of contact of a tooth pair. According to figure 12, the left-hand tooth pair is in the individual point of contact D while the right-hand tooth pair gets into mesh at the starting point of engagement A. The right-hand tooth pair is in the individual point of contact B when the left-hand tooth pair leaves the mesh at the finishing point of engagement E. Along the individual length of path of contact \overline{BD} one tooth pair is in mesh, and along the double lengths of paths of contact \overline{AB} and \overline{DE} two pairs of teeth are simultaneously in mesh.

In the case of helical gear pairs it is possible to achieve that always two or more pairs of teeth are in mesh simultaneously. The overlap ratio ϵ_β gives the contact ratio, owing to the helix of the teeth, as the ratio of the facewidth b to the axial pitch p_{ex} , i.e. $\epsilon_\beta = b / p_{ex}$, see figure 13.

The total contact ratio ϵ_γ is the sum of transverse contact ratio and overlap ratio, i.e. $\epsilon_\gamma = \epsilon_\alpha + \epsilon_\beta$. With an increasing total contact ratio, the load carrying capacity increases, as a rule, while the generation of noise is reduced.

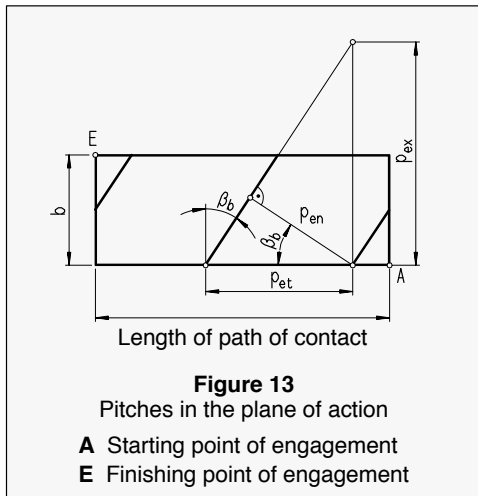
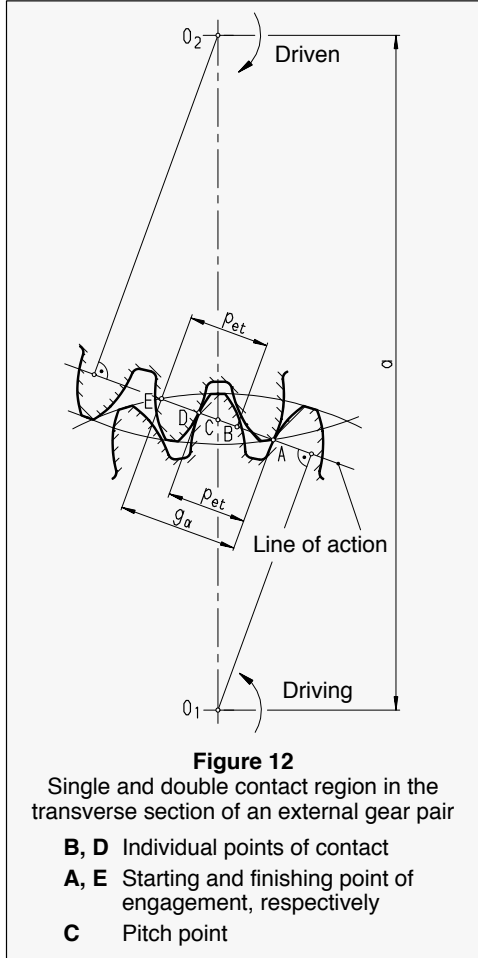

1.2.4 Summary of the most important formulae

Tables 2 and 3 contain the most important formulae for the determination of sizes of a cylindrical gear and a cylindrical gear pair, and this for both external and internal gear pairs.

The following rules for signs are to be observed: In the case of internal gear pairs the number of teeth z_2 of the internal gear is a negative quantity. Thus, also the centre distance a or a_d and the gear ratio u as well as the diameters d_2 , d_{a2} , d_{b2} , d_{f2} , d_{w2} and the virtual number of teeth z_{n2} are negative.

When designing a cylindrical gear pair for a gear stage, from the output quantities of tables 2 and 3 only the normal pressure angle α_n and the gear ratio u are given, as a rule. The number of teeth of

the pinion is determined with regard to silent running and a balanced foot and flank load carrying capacity, at approx. $z_1 = 18 \dots 23$. If a high foot load carrying capacity is required, the number may be reduced to $z_1 = 10$. For the helix angle, $\beta = 10$ up to 15 degree is given, in exceptional cases also up to 30 degree. The addendum modification limits as shown in figure 9 are to be observed. On the pinion, the addendum modification coefficient should be within the range of $x_1 = 0.2$ up to 0.6 and from $|u| > 2$ the width within the range $b_1 = (0.35 \text{ to } 0.45) a$. Centre distance a is determined either by the required power to be transmitted or by the constructional conditions.

Cylindrical Gear Units

Geometry of Involute Gears

Table 2 Parameters for a cylindrical gear *)

Output quantities:		
m_n	mm	normal module
α_n	degree	normal pressure angle
β	degree	reference helix angle
z	–	number of teeth *)
x	–	addendum modification coefficient
x_E	–	generating addendum modification coefficient, see equation (3)
h_{aP0}	mm	addendum of the tool
Item	Formula	
Transverse module	$m_t = \frac{m_n}{\cos\beta}$	
Transverse pressure angle	$\tan\alpha_t = \frac{\tan\alpha_n}{\cos\beta}$	
Base helix angle	$\sin\beta_b = \sin\beta \cdot \cos\alpha_n$	
Reference diameter	$d = m_t \cdot z$	
Tip diameter (for k , see table 3)	$d_a = d + 2 m_n (1 + x + k)$	
Root diameter	$d_f = d - 2 (h_{aP0} - m_n \cdot x_E)$	
Base diameter	$d_b = d \cdot \cos\alpha_t$	
Transverse pitch	$p_t = \frac{\pi \cdot d}{z} = \pi \cdot m_t$	
Transverse pitch on path of contact; Transverse base pitch	$p_{et} = p_{bt} = \frac{\pi \cdot d_b}{z} = p_t \cdot \cos\alpha_t$	
Transverse pressure angle at tip circle	$\cos\alpha_{at} = \frac{d_b}{d_a}$	
Transverse tooth thickness on the pitch circle	$s_t = m_t \left(\frac{\pi}{2} + 2 \cdot x \cdot \tan\alpha_n \right)$	
Normal tooth thickness on the pitch circle	$s_n = s_t \cdot \cos\beta$	
Transverse tooth thickness on the addendum circle	$s_{at} = d_a \left(\frac{s_t}{d} + \text{inv}\alpha_t - \text{inv}\alpha_{at} \right)$ **)	
Virtual number of teeth	$z_n = \frac{z}{\cos\beta \cdot \cos^2\beta_b}$	

*) For an internal gear, z is to be used as a negative quantity. **) For $\text{inv}\alpha$, see equation (1).

Cylindrical Gear Units

Geometry of Involute Gears

Table 3 Parameters for a cylindrical gear pair *)

Output quantities:

The parameters for pinion and wheel according to table 2 must be given, further the facewidths b_1 and b_2 , as well as either the centre distance a or the sum of the addendum modification coefficients $x_1 + x_2$.

Item	Formula
Gear ratio	$u = \frac{z_2}{z_1}$
Working transverse pressure angle ("a" given)	$\cos\alpha_{wt} = \frac{m_t}{2 \cdot a} (z_1 + z_2) \cos\alpha_t$
Sum of the addendum modification coefficients	$x_1 + x_2 = \frac{z_1 + z_2}{2 \cdot \tan\alpha_n} (\text{inv}\alpha_{wt} - \text{inv}\alpha_t)$
Working transverse pressure angle ($x_1 + x_2$ given)	$\text{inv}\alpha_{wt} = 2 \frac{x_1 + x_2}{z_1 + z_2} \tan\alpha_n + \text{inv}\alpha_t$
Centre distance	$a = \frac{m_t}{2} (z_1 + z_2) \frac{\cos\alpha_t}{\cos\alpha_{wt}}$
Reference centre distance	$a_d = \frac{m_t}{2} (z_1 + z_2) = \frac{d_1 + d_2}{2}$
Addendum modification factor (**)	$k = \frac{a - a_d}{m_n} - (x_1 + x_2)$
Working pitch circle diameter of the pinion	$d_{w1} = \frac{2 \cdot a}{u + 1} = d_1 \frac{\cos\alpha_t}{\cos\alpha_{wt}}$
Working pitch circle diameter of the gear	$d_{w2} = \frac{2 \cdot a \cdot u}{u + 1} = d_2 \frac{\cos\alpha_t}{\cos\alpha_{wt}}$
Length of path of contact	$g_\alpha = \frac{1}{2} \left(\sqrt{d_{a1}^2 - d_{b1}^2} + \frac{u}{ u } \sqrt{d_{a2}^2 - d_{b2}^2} \right) - a \cdot \sin\alpha_{wt}$
Transverse contact ratio	$\epsilon_\alpha = \frac{g_\alpha}{p_{et}}$
Overlap ratio	$\epsilon_\beta = \frac{b \cdot \tan\beta_b}{p_{et}} \quad b = \min(b_1, b_2)$
Total contact ratio	$\epsilon_\gamma = \epsilon_\alpha + \epsilon_\beta$

*) For internal gear pairs, z_2 and a are to be used as negative quantities.

**) See subsection 1.2.3.2.

Cylindrical Gear Units

Geometry of Involute Gears

1.2.5 Gear teeth modifications

The parameters given in the above subsections 1.2.1 to 1.2.4 refer to non-deviating cylindrical gears. Because of the high-tensile gear materials, however, a high load utilization of the gear units is possible. Noticeable deformations of the elastic gear unit components result from it. The deflection at the tooth tips is, as a rule, a multiple of the manufacturing form errors. This leads to meshing interferences at the entering and leaving sides, see figure 14. There is a negative effect on the load carrying capacity and generation of noise.

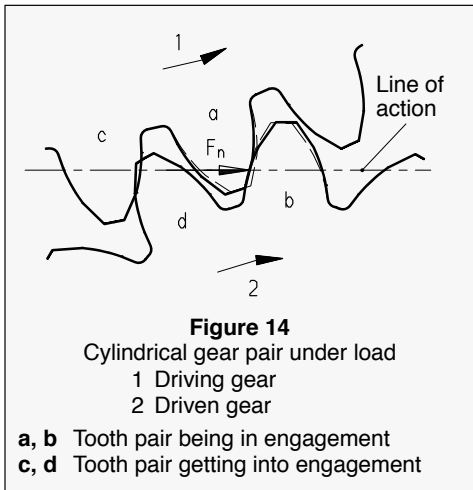

Further, the load causes bending and twisting of pinion and wheel shaft, pinion and wheel body, as well as settling of bearings, and housing deformations. This results in skewing of the tooth flanks which often amounts considerably higher than the tooth trace deviations caused by manufacture, see figure 15. Non-uniform load carrying occurs along the face width which also has a negative effect on the load carrying capacity and generation of noise.

The running-in wear of case hardened gears amounts to a few micrometers only and cannot compensate the mentioned deviations. In order to restore the high load carrying capacity of case hardened gears and reduce the generation of noise, intentional deviations from the involute (profile correction) and from the theoretical tooth trace (longitudinal correction) are produced in order to attain nearly ideal geometries with uniform load distribution under load again. The load-related form corrections are calculated and made for one load only – as a rule for 70 ... 100% of the permanently acting nominal load – /5, 6, 7/. At low partial load, contact patterns which do not cover the entire tooth depth and

facewidth are achieved. This has to be taken into consideration especially in the case of checks of contact patterns carried out under low loads. Under partial load, however, the local maximum load rise is always lower than the theoretical uniform load distribution under full load. In the case of modified gear teeth, the contact ratio is reduced under partial load because of incomplete carrying portions, making the noise generating levels increase in the lower part load range. With increasing load, the carrying portions and thus the contact ratio increase so that the generating levels drop. Gear pairs which are only slightly loaded do not require any modification.

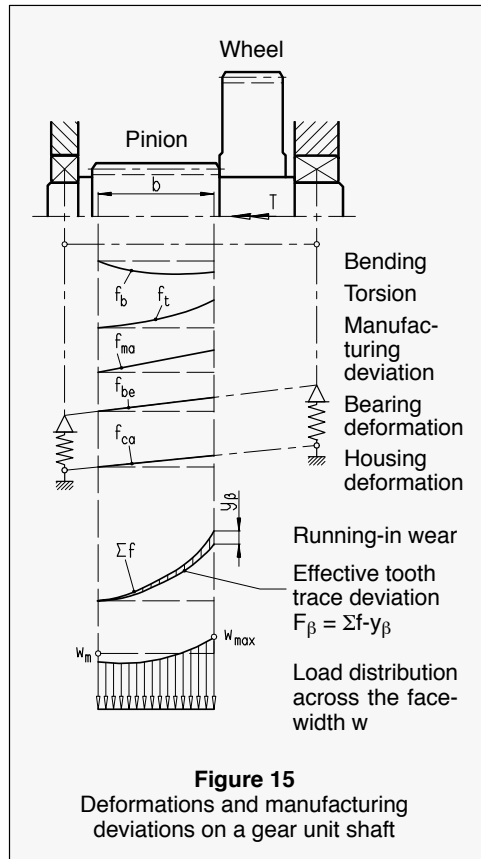

In figure 16, usual profile and longitudinal corrections are illustrated. In the case of profile correction, the flanks on pinion and wheel are relieved at the tips by an amount equal to the length they are protruding at the entering and leaving sides due to the bending deflection of the teeth. Root relief may be applied instead of tip relief which, however, is much more expensive. Thus, a gradual load increase is achieved on the tooth

Cylindrical Gear Units

Geometry of Involute Gears

Load Carrying Capacity of Involute Gears

getting into engagement, and a load reduction on the tooth leaving the engagement. In the case of longitudinal correction, the tooth trace relief often is superposed by a symmetric lon-

gitudinal crowning. With it, uniform load carrying along the facewidth and a reduction in load concentration at the tooth ends during axial displacements is attained.

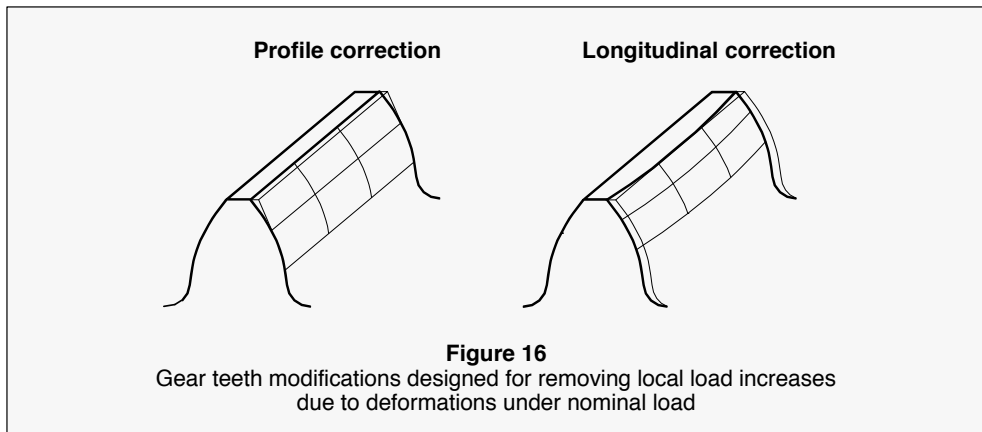

1.3 Load carrying capacity of involute gears

1.3.1 Scope of application and purpose

The calculation of the load carrying capacity of cylindrical gears is generally carried out in accordance with the calculation method according to DIN 3990 /8/ (identical with ISO 6336) which takes into account pitting, tooth root bending stress and scoring as load carrying limits. Because of the relatively large scope of standards, the calculation in accordance with this method may be carried out only by using EDP programs. As a rule, gear unit manufacturers have such a tool at hand. The standard work is the FVA-Stirnradprogramm /9/ which includes further calculation methods, for instance, according to Niemann, AGMA, DNV, LRS, and others.

In DIN 3990, different methods A, B, C ... are suggested for the determination of individual factors, where method A is more exact than method B, etc. The application standard /10/ according to DIN 3990 is based on simplified methods.

Because of its – even though limited – universal validity it still is relatively time-consuming.

The following calculation method for pitting resistance and tooth strength of case-hardened cylindrical gears is a further simplification if compared with the application standard, however, without losing some of its meaning. Certain conditions must be adhered to in order to attain high load carrying capacities which also results in preventing scuffing. Therefore, a calculation of load carrying capacity for scuffing will not be considered in the following.

It has to be expressly emphasized that for the load carrying capacity of gear units the exact calculation method – compared with the simplified one – is always more meaningful and therefore is exclusively decisive in borderline cases.

Design, selection of material, manufacture, heat treatment, and operation of industrial gear units are subject to certain rules which lead to a long service life of the cylindrical gears.

Those rules are:

- Gear teeth geometry acc. to DIN 3960;
- Cylindrical gears out of case-hardened steel; Tooth flanks in DIN quality 6 or better, fine machined;
- Quality of material and heat treatment proved by quality inspections acc. to DIN 3990 /11/;
- Effective case depth after carburizing according to instructions /12/ with surface hardnesses of 58 ... 62 HRC;
- Gears with required tooth corrections and without harmful notches in the tooth root;
- Gear unit designed for fatigue strength, i.e. life factors $Z_{NT} = Y_{NT} = 1.0$;
- Flank fatigue strength $\sigma_{Hlim} \geq 1200 \text{ N/mm}^2$;
- Subcritical operating range, i.e. pitch circle velocity lower than approx. 35 m/s;
- Sufficient supply of lubricating oil;
- Use of prescribed gear oils of criteria stage 12 acc. to the gear rig test by the FZG-method and sufficient grey staining load capacity;
- Maximum operating temperature 95 °C.

Cylindrical Gear Units

Load Carrying Capacity of Involute Gears

If these requirements are met, a number of factors can be definitely given for the calculation of the load carrying capacity according to DIN 3990, so that the calculation procedure is partly considerably simplified. Non-observance of the above requirements, however, does not necessarily mean that the load carrying capacity is reduced. In case of doubt one should, however, carry out the calculation in accordance with the more exact method.

1.3.2 Basic details

The calculation of the load carrying capacity is

based on the nominal torque of the driven machine. Alternatively, one can also start from the nominal torque of the prime mover if this corresponds with the torque requirement of the driven machine.

In order to be able to carry out the calculation for a cylindrical gear stage, the details listed in table 4 must be given in the units mentioned in the table. The geometric quantities are calculated according to tables 2 and 3. Usually, they are contained in the workshop drawings for cylindrical gears.

Table 4 Basic details

Abbreviation	Meaning	Unit
P	Power rating	kW
n_1	Pinion speed	min^{-1}
a	Centre distance	mm
m_n	Normal module	mm
d_{a1}	Tip diameter of the pinion	mm
d_{a2}	Tip diameter of the wheel	mm
b_1	Facewidth of the pinion	mm
b_2	Facewidth of the wheel	mm
z_1	Number of teeth of the pinion	–
z_2	Number of teeth of the wheel	–
x_1	Addendum modification coefficient of the pinion	–
x_2	Addendum modification coefficient of the wheel	–
α_n	Normal pressure angle	Degree
β	Reference helix angle	Degree
ν_{40}	Kinematic viscosity of lubricating oil at 40 °C	mm^2/s
R_{z1}	Peak-to-valley height on pinion flank	μm
R_{z2}	Peak-to-valley height on wheel flank	μm

Cylindrical Gear Units

Load Carrying Capacity of Involute Gears

In the further course of the calculation, the quantities listed in table 5 are required. They are derived from the basic details according to table 4.

Table 5 Derived quantities		
Designation	Relation	Unit
Gear ratio	$u = z_2 / z_1$	–
Reference diameter of the pinion	$d_1 = z_1 \cdot m_n / \cos\beta$	mm
Transverse tangential force at pinion reference circle	$F_t = \frac{6 \cdot 10^7}{\pi} \cdot \frac{P}{d_1 \cdot n_1}$	N
Transverse tangential force at pitch circle	$F_u = F_t \cdot \frac{d_1}{2 \cdot a} (u + 1)$	N
Circumferential speed at reference circle	$v = \pi \cdot d_1 \cdot n_1 / 60000$	m/s
Base helix angle	$\beta_b = \arcsin(\cos\alpha_n \cdot \sin\beta)$	Degree
Virtual number of teeth of the pinion	$z_{n1} = z_1 / (\cos\beta \cdot \cos^2\beta_b)$	–
Virtual number of teeth of the wheel	$z_{n2} = z_2 / (\cos\beta \cdot \cos^2\beta_b)$	–
Transverse module	$m_t = m_n / \cos\beta$	mm
Transverse pressure angle	$\alpha_t = \arctan(\tan\alpha_n / \cos\beta)$	Degree
Working transverse pressure angle	$\alpha_{wt} = \arccos\left[\frac{z_1 + z_2}{z_1 + z_2} m_t \cdot \cos\alpha_t / (2 \cdot a)\right]$	Degree
Transverse pitch	$p_{et} = \pi \cdot m_t \cdot \cos\alpha_t$	mm
Base diameter of the pinion	$d_{b1} = z_1 \cdot m_t \cdot \cos\alpha_t$	mm
Base diameter of the wheel	$d_{b2} = z_2 \cdot m_t \cdot \cos\alpha_t$	mm
Length of path of contact	$g_\alpha = \frac{1}{2} \left(\sqrt{d_{a1}^2 - d_{b1}^2} + \frac{u}{ u } \sqrt{d_{a2}^2 - d_{b2}^2} \right) - a \cdot \sin\alpha_{wt}$	mm
Transverse contact ratio	$\epsilon_\alpha = g_\alpha / p_{et}$	–
Overlap ratio	$\epsilon_\beta = b \cdot \tan\beta_b / p_{et} \quad b = \min(b_1, b_2)$	–

Cylindrical Gear Units

Load Carrying Capacity of Involute Gears

1.3.3 General factors

1.3.3.1 Application factor

With the application factor K_A , all additional forces acting on the gears from external sources are taken into consideration. It is dependent on the characteristics of the driving and driven machines, as well as the couplings, the masses and stiffness of the system, and the operating conditions.

The application factor is determined by the service classification of the individual gear. If possible, the factor K_A should be determined by means of a careful measurement or a comprehensive analysis of the system. Since very often it is not possible to carry out the one or other method without great expenditure, reference values are given in table 6 which equally apply to all gears in a gear unit.

Working mode of prime mover	Working mode of the driven machine			
	Uniform	Moderate shock loads	Average shock loads	Heavy shock loads
Uniform	1.00	1.25	1.50	1.75
Moderate shock loads	1.10	1.35	1.60	1.85
Average shock loads	1.25	1.50	1.75	2.00 or higher
Heavy shock loads	1.50	1.75	2.00	2.25 or higher

1.3.3.2 Dynamic factor

With the dynamic factor K_v , additional internal dynamic forces caused in the meshing are taken into consideration. Taking z_1 , v and u from tables 4 and 5, it is calculated from

$$K_v = 1 + 0.0003 \cdot z_1 \cdot v \sqrt{\frac{u^2}{1 + u^2}} \quad (4)$$

1.3.3.3 Face load factor

The face load factor $K_{H\beta}$ takes into account the increase in the load on the tooth flanks caused by non-uniform load distribution over the facewidth. According to /8/, it can be determined by means of different methods. Exact methods based on comprehensive measurements or calculations or on a combination of both are very expensive. Simple methods, however, are not exact, as a consequence of which estimations made to be on the safe side mostly result in higher factors. For normal cylindrical gear teeth without longitudinal correction, the face load factor can be calculated according to method D in accordance with /8/ dependent on facewidth b and reference diameter d_1 of the pinion, as follows:

$$K_{H\beta} = 1.15 + 0.18 (b/d_1)^2 + 0.0003 \cdot b \quad (5)$$

with $b = \min(b_1, b_2)$. As a rule, the gear unit manufacturer carries out an analysis of the load distribution over the facewidth in accordance with an exact calculation method /13/. If required, he makes longitudinal corrections in order to

attain uniform load carrying over the facewidth, see subsection 1.2.5. Under such conditions, the face load factor lies within the range of $K_{H\beta} = 1.1 \dots 1.25$. As a rough rule applies: A sensibly selected crowning symmetrical in length reduces the amount of $K_{H\beta}$ lying above 1.0 by approx. 40 to 50%, and a directly made longitudinal correction by approx. 60 to 70%.

In the case of slim shafts with gears arranged on one side, or in the case of lateral forces or moments acting on the shafts from external sources, for the face load factors for gears without longitudinal correction the values may lie between 1.5 and 2.0 and in extreme cases even at 2.5.

Face load factor $K_{F\beta}$ for the determination of increased tooth root stress can approximately be deduced from face load factor $K_{H\beta}$ according to the relation

$$K_{F\beta} = (K_{H\beta})^{0.9} \quad (6)$$

1.3.3.4 Transverse load factors

The transverse load factors $K_{H\alpha}$ and $K_{F\alpha}$ take into account the effect of the non-uniform distribution of load between several pairs of simultaneously contacting gear teeth. Under the conditions as laid down in subsection 1.3.1, the result for surface stress and for tooth root stress according to method B in accordance with /8/ is

$$K_{H\alpha} = K_{F\alpha} = 1.0 \quad (7)$$

Cylindrical Gear Units

Load Carrying Capacity of Involute Gears

1.3.4 Tooth flank load carrying capacity

The calculation of surface durability against pitting is based on the Hertzian pressure at the pitch circle. For pinion and wheel the same effective Hertzian pressure σ_H is assumed. It must not exceed the permissible Hertzian pressure σ_{HP} , i.e. $\sigma_H \leq \sigma_{HP}$.

$$\sigma_H = Z_E Z_H Z_\beta Z_\epsilon \sqrt{K_A K_V K_{H\alpha} K_{H\beta} \frac{u+1}{u} \frac{F_t}{d_1 \cdot b}} \quad (8)$$

σ_H Effective Hertzian pressure in N/mm²

Further:

b Common facewidth of pinion and wheel

F_t, u, d_1 acc. to table 5

K_A Application factor acc. to table 6

K_V Dynamic factor acc. to equation (4)

$K_{H\beta}$ Face load factor acc. to eq (5)

$K_{H\alpha}$ Transverse load factor acc. to eq (7)

Z_E Elasticity factor; $Z_E = 190 \sqrt{N/mm^2}$ for gears out of steel

Z_H Zone factor acc. to figure 17

Z_β Helix angle factor acc. to eq (9)

Z_ϵ Contact ratio factor acc. to eq (10) or (11)

With β according to table 4 applies:

$$Z_\beta = \sqrt{\cos \beta} \quad (9)$$

With ϵ_α and ϵ_β according to table 5 applies:

$$Z_\epsilon = \sqrt{\frac{4 - \epsilon_\alpha (1 - \epsilon_\beta) + \frac{\epsilon_\beta}{\epsilon_\alpha}}{3}} \quad \text{for } \epsilon_\beta < 1 \quad (10)$$

$$Z_\epsilon = \sqrt{\frac{1}{\epsilon_\alpha}} \quad \text{for } \epsilon_\beta \geq 1 \quad (11)$$

1.3.4.2 Permissible Hertzian pressure

The permissible Hertzian pressure is determined by

$$\sigma_{HP} = Z_L Z_V Z_X Z_R Z_W \frac{\sigma_{Hlim}}{S_H} \quad (12)$$

σ_{HP} permissible Hertzian pressure in N/mm². It is of different size for pinion and wheel if the strengths of materials σ_{Hlim} are different. Factors Z_L, Z_V, Z_R, Z_W and Z_X are the same for

1.3.4.1 Effective Hertzian pressure

The effective Hertzian pressure is dependent on the load, and for pinion and wheel is equally derived from the equation

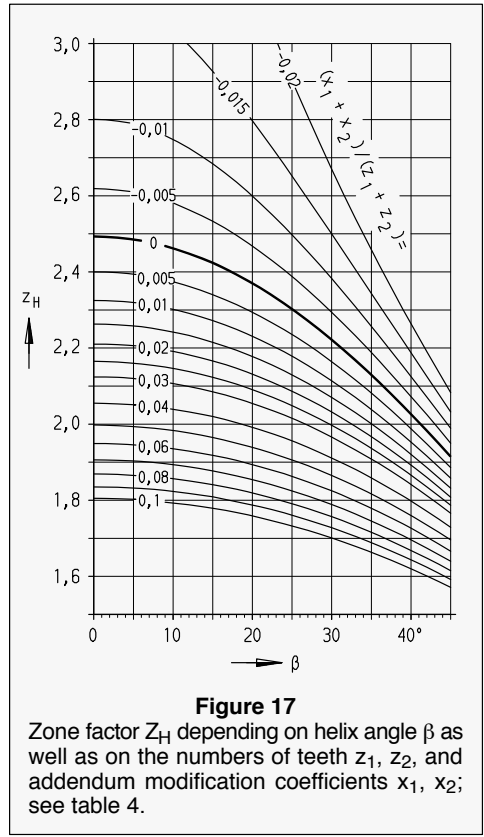

Figure 17
Zone factor Z_H depending on helix angle β as well as on the numbers of teeth z_1, z_2 , and addendum modification coefficients x_1, x_2 ; see table 4.

pinion and wheel and are determined in the following.

The lubricant factor is computed from the lubricating oil viscosity ν_{40} according to table 4 using the following formula:

$$Z_L = 0.91 + \frac{0.25}{\left(1 + \frac{112}{\nu_{40}}\right)^2} \quad (13)$$

Cylindrical Gear Units

Load Carrying Capacity of Involute Gears

For the speed factor, the following applies using the circumferential speed v according to table 5:

$$Z_v = 0.93 + \frac{0.157}{\sqrt{1 + \frac{40}{v}}} \quad (14)$$

The roughness factor can be determined as a function of the mean peak-to-valley height $R_z = (R_{z1} + R_{z2})/2$ of the gear pair as well as the gear ratio u and the reference diameter d_1 of the pinion, see tables 4 and 5, from

$$Z_R = \left[\frac{0.513}{R_z} \sqrt[3]{(1 + |u|) d_1} \right]^{0.08} \quad (15)$$

For a gear pair with the same tooth flank hardness on pinion and wheel, the work hardening factor is

$$Z_W = 1.0 \quad (16)$$

The size factor is computed from module m_n according to table 4 using the following formula:

$$Z_X = 1.05 - 0.005 m_n \quad (17)$$

with the restriction $0.9 \leq Z_X \leq 1$.

σ_{Hlim} Endurance strength of the gear material. For gears made out of case hardening steel, case hardened, figure 18 shows a range from 1300 ... 1650 N/mm² depending on the surface hardness of the tooth flanks and the quality of the material. Under the conditions as described in subsection 1.3.1, material quality MQ may be selected for pinion and wheel, see table on page 77.

S_H Required safety factor against pitting, see subsection 1.3.6.

1.3.5 Tooth strength

The maximum load in the root fillet at the 30-degree tangent is the basis for rating the tooth strength. For pinion and wheel it shall be shown separately that the effective tooth root stress σ_F does not exceed the permissible tooth root stress σ_{FP} , i.e. $\sigma_F < \sigma_{FP}$.

1.3.5.1 Effective tooth root stress

As a rule, the load-dependent tooth root stresses for pinion and wheel are different. They are calculated from the following equation:

$$\sigma_F = K_A K_V K_{F\alpha} K_{F\beta} \cdot \frac{F_t}{b \cdot m_n} \cdot Y_{FS} Y_\beta Y_\epsilon \quad (18)$$

σ_F Effective tooth root stress in N/mm²

The following factors are of equal size for pinion and wheel:

m_n, F_t acc. to tables 4 and 5

K_A Application factor acc. to table 6

K_V Dynamic factor acc. to equation (4)

$K_{F\beta}$ Face load factor acc. to equation (6)

$K_{F\alpha}$ Transverse load factor acc. to eq (7)

Y_ϵ Contact ratio factor acc. to eq (19)

Y_β Helix angle factor acc. to eq (20)

The following factors are of different size for pinion and wheel:

b_1, b_2 Facewidths of pinion and wheel acc. to table 4. If the facewidths of pinion and wheel are different, it may be assumed that the load bearing width of the wider facewidth is equal to the smaller facewidth plus such extension of the wider that does not exceed one times the module at each end of the teeth.

Y_{FS1}, Y_{FS2} Tip factors acc. to figure 19. They account for the complex stress condition inclusive of the notch effect in the root fillet.

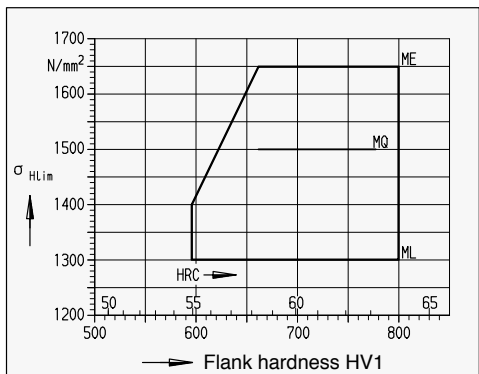

Figure 18

Allowable stress number for contact stress σ_{Hlim} of alloyed case hardening steels, case hardened, depending on the surface hardness HV1 of the tooth flanks and the material quality.

ML modest demands on the material quality
MQ normal demands on the material quality
ME high demands on the material quality, see /11/

Cylindrical Gear Units

Load Carrying Capacity of Involute Gears

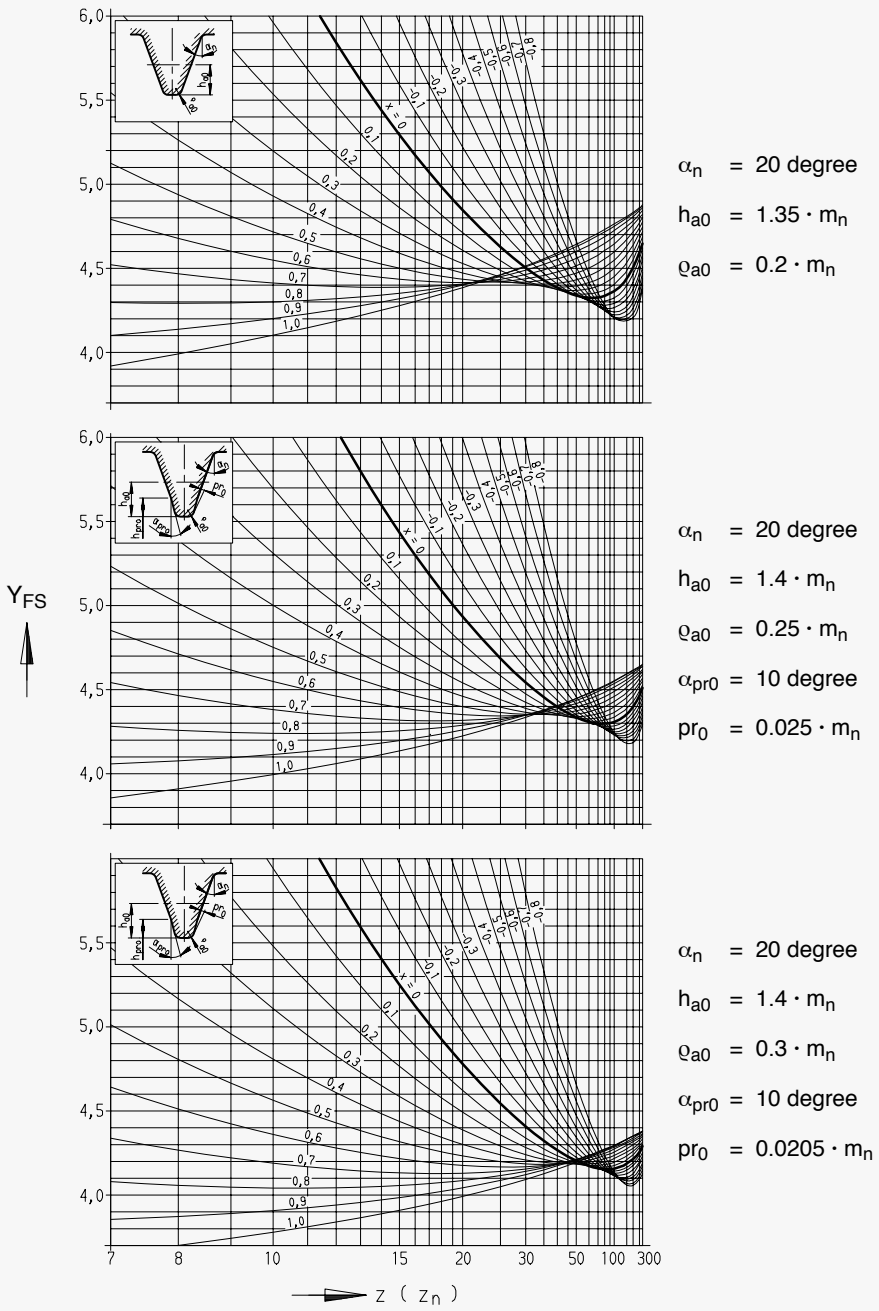

Figure 19

Tip factor Y_{FS} for external gears with standard basic rack tooth profile acc. to DIN 867 depending on the number of teeth z (or z_n in case of helical gears) and addendum modification coefficient x , see tables 4 and 5. The following only approximately applies to internal gears: $Y_{FS} = Y_{FS\infty}$ (\approx value for $x = 1.0$ and $z = 300$).

Cylindrical Gear Units

Load Carrying Capacity of Involute Gears

With the helix angle β acc. to table 4 and the overlap ratio ε_β acc. to table 5 follows:

$$Y_\varepsilon = 0.25 + \frac{0.75}{\varepsilon_\alpha} \cdot \cos^2\beta \quad (19)$$

with the restriction $0.625 \leq Y_\varepsilon \leq 1$

$$Y_\beta = 1 - \varepsilon_\beta \cdot \frac{\beta}{120^\circ} \quad (20)$$

with the restriction

$$Y_\beta \geq \max. [(1 - 0.25 \varepsilon_\beta); (1 - \beta/120)].$$

1.3.5.2 Permissible tooth root stress

The permissible tooth root stress for pinion and wheel is determined by

$$\sigma_{FP} = Y_{ST} Y_{\delta_{relT}} Y_{R_{relT}} Y_X \frac{\sigma_{Flim}}{(S_F)} \quad (21)$$

σ_{FP} permissible tooth root stress in N/mm^2 .

It is not equal for pinion and wheel if the material strengths σ_{Flim} are not equal. Factors Y_{ST} , $Y_{\delta_{relT}}$, $Y_{R_{relT}}$ and Y_X may be approximately equal for pinion and wheel.

Y_{ST} is the stress correction factor of the reference test gears for the determination of the bending stress number σ_{Flim} . For standard reference test gears, $Y_{ST} = 2.0$ has been fixed in the standard.

$Y_{\delta_{relT}}$ is the relative sensitivity factor (notch sensitivity of the material) referring to the standard reference test gear. By approximation $Y_{\delta_{relT}} = 1.0$.

For the relative surface factor (surface roughness factor of the tooth root fillet) referring to the standard reference test gear the following applies by approximation, depending on module m_n :

$$Y_{R_{relT}} = \begin{cases} 1.00 & \text{for } m_n \leq 8 \text{ mm} \\ 0.98 & \text{for } 8 \text{ mm} < m_n \leq 16 \text{ mm} \\ 0.96 & \text{for } m_n > 16 \text{ mm} \end{cases} \quad (22)$$

and for the size factor

$$Y_X = 1.05 - 0.01 m_n \quad (23)$$

with the restriction $0.8 \leq Y_X \leq 1$.

σ_{Flim} Bending stress number of the gear material. For gears out of case hardening steel, case hardened, a range from 310 ... 520 N/mm^2 is shown in figure 20 depending on the surface hardness of the tooth flanks and the material quality. Under the conditions according to subsection 1.3.1, a strength pertaining to quality MQ may be used as a basis for pinion and wheel, see table on page 77.

S_F Safety factor required against tooth breakage, see subsection 1.3.6.

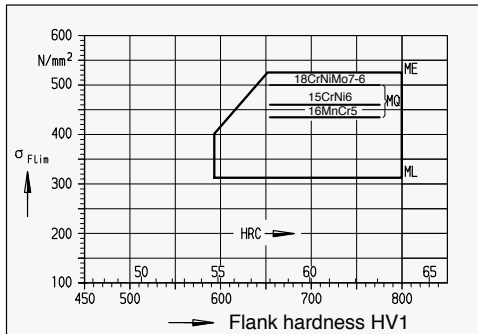

Figure 20

Bending stress number σ_{Flim} of alloyed case hardening steel, case hardened, depending on the surface hardness HV1 of the tooth flanks and the material quality.

ML modest demands on the material quality
MQ normal demands on the material quality
ME high demands on the material quality, see /11/

1.3.6 Safety factors

The minimum required safety factors according to DIN are:

against pitting $S_H = 1.0$
against tooth breakage $S_F = 1.3$.

In practice, higher safety factors are usual. For multistage gear units, the safety factors are determined about 10 to 20% higher for the expensive final stages, and in most cases even higher for the cheaper preliminary stages.

Also for risky applications a higher safety factor is given.

1.3.7 Calculation example

An electric motor drives a coal mill via a multistage cylindrical gear unit. The low speed gear stage is to be calculated.

Given: Nominal power rating $P = 3300$ kW; pinion speed $n_1 = 141 \text{ min}^{-1}$; centre distance $a = 815$ mm; normal module $m_n = 22$ mm; tip diameter $d_{a1} = 615.5$ mm and $d_{a2} = 1100$ mm; pinion and wheel widths $b_1 = 360$ mm and $b_2 = 350$ mm; numbers of teeth $z_1 = 25$ and $z_2 = 47$; addendum modification coefficients $x_1 = 0.310$ and $x_2 = 0.203$; normal pressure angle $\alpha_n = 20$ degree; helix angle $\beta = 10$ degree; kinematic viscosity of the lubricating oil $\nu_{40} = 320$ cSt; mean peak-to-valley roughness $R_{z1} = R_{z2} = 4.8$ μm .

The cylindrical gears are made out of the material 18CrNiMo7-6. They are case hardened and ground with profile corrections and width-symmetrical crowning.

Cylindrical Gear Units

Load Carrying Capacity of Involute Gears Gear Unit Types

Calculation (values partly rounded):

Gear ratio $u = 1.88$; reference diameter of the pinion $d_1 = 558.485$ mm; nominal circumferential force on the reference circle $F_t = 800425$ N; circumferential speed on the reference circle $v = 4.123$ m/s; base helix angle $\beta_b = 9.391$ degree; virtual numbers of teeth $z_{n1} = 26.08$ and $z_{n2} = 49.03$; transverse module $m_t = 22.339$ mm; transverse pressure angle $\alpha_t = 20.284$ degree; working transverse pressure angle $\alpha_{wt} = 22.244$ degree; normal transverse pitch $p_{et} = 65.829$ mm; base diameters $d_{b1} = 523.852$ mm and $d_{b2} = 984.842$ mm; length of path of contact $g_\alpha = 98.041$ mm; transverse contact ratio $\varepsilon_\alpha = 1.489$; overlap ratio $\varepsilon_\beta = 0.879$.

Application factor $K_A = 1.50$ (electric motor with uniform mode of operation, coal mill with medium shock load); dynamic factor $K_V = 1.027$; face load factor $K_{H\beta} = 1.20$ [acc. to equation (5) follows $K_{H\beta} = 1.326$, however, because of symmetrical crowning the calculation may be made with a smaller value]; $K_{F\beta} = 1.178$; $K_{H\alpha} = K_{F\alpha} = 1.0$.

Load carrying capacity of the tooth flanks:

Elasticity factor $Z_E = 190 \sqrt{\text{N/mm}^2}$; zone factor $Z_H = 2.342$; helix angle factor $Z_\beta = 0.992$; contact ratio factor $Z_\varepsilon = 0.832$. According to equation (8), the Hertzian pressure for pinion and wheel is $\sigma_H = 1251$ N/mm².

Lubricant factor $Z_L = 1.047$; speed factor $Z_V = 0.978$; roughness factor $Z_R = 1.018$; work hardening factor $Z_W = 1.0$; size factor $Z_X = 0.94$. With the allowable stress number for contact stress (pitting) $\sigma_{Hlim} = 1500$ N/mm², first the permissible Hertzian pressure $\sigma_{HP} = 1470$ N/mm² is determined from equation (12) without taking into account the safety factor.

The safety factor against pitting is found by $S_H = \sigma_{HP}/\sigma_H = 1470/1251 = 1.18$. The safety factor referring to the torque is $S_H^2 = 1.38$.

Load carrying capacity of the tooth root:

Contact ratio factor $Y_\varepsilon = 0.738$; helix angle factor $Y_\beta = 0.927$; tip factors $Y_{FS1} = 4.28$ and $Y_{FS2} = 4.18$ (for $h_{a0} = 1.4 m_n$; $q_{a0} = 0.3 m_n$; $\alpha_{pr0} = 10$ degree; $pr_0 = 0.0205 m_n$). The effective tooth root stresses $\sigma_{F1} = 537$ N/mm² for the pinion and $\sigma_{F2} = 540$ N/mm² for the wheel can be obtained from equation (18).

Stress correction factor $Y_{ST} = 2.0$; relative sensitivity factor $Y_{relT} = 1.0$; relative surface factor $Y_{RrelT} = 0.96$; size factor $Y_X = 0.83$. Without taking into consideration the safety factor, the permissible tooth root stresses for pinion and wheel $\sigma_{FP1} = \sigma_{FP2} = 797$ N/mm² can be obtained from equation (21) with the bending stress number $\sigma_{Flim} = 500$ N/mm².

The safety factors against tooth breakage referring to the torque are $S_F = \sigma_{FP}/\sigma_F$: for the pinion $S_{F1} = 797/537 = 1.48$ and for the wheel $S_{F2} = 797/540 = 1.48$.

1.4 Gear unit types

1.4.1 Standard designs

In the industrial practice, different types of gear units are used. Preferably, standard helical and bevel-helical gear units with fixed transmission ratio and size gradation are applied. These single-stage to four-stage gear units according to the modular construction system cover a wide range of speeds and torques required by the driven machines. Combined with a standard electric motor such gear units are, as a rule, the most economical drive solution.

But there are also cases where no standard drives are used. Among others, this is true for high torques above the range of standard gear units. In such cases, special design gear units are used, load sharing gear units playing an important role there.

1.4.2 Load sharing gear units

In principle, the highest output torques of gear units are limited by the manufacturing facilities, since gear cutting machines can make gears up to a maximum diameter only. Then, the output torque can be increased further only by means of load sharing in the gear unit. Load sharing gear units are, however, also widely used for lower torques as they provide certain advantages in spite of the larger number of internal components, among others they are also used in standard design. Some typical features of the one or other type are described in the following.

1.4.3 Comparisons

In the following, single-stage and two-stage gear units up to a ratio of $i = 16$ are examined. For common gear units the last or the last and the last but one gear stage usually come to approx. 70 to 80% of the total weight and also of the manufacturing expenditure. Adding further gear stages in order to achieve higher transmission ratios thus does not change anything about the following fundamental description.

In figure 21, gear units without and with load sharing are shown, shaft 1 each being the HSS and shaft 2 being the LSS. With speeds n_1 and n_2 , the transmission ratio can be obtained from the formula

$$i = n_1 / n_2 \quad (24)$$

Cylindrical Gear Units

Gear Unit Types

The diameter ratios of the gears shown in figure 21 correspond to the transmission ratio $i = 7$. The gear units have the same output torques, so that in figure 21 a size comparison to scale is illustrated. Gear units A, B, and C are with offset shaft arrangement, and gear units D, E, F, and G with coaxial shaft arrangement.

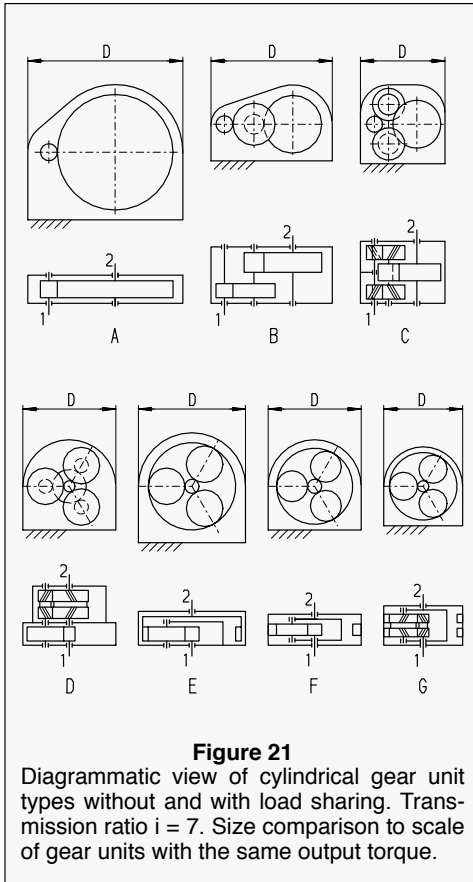

Figure 21

Diagrammatic view of cylindrical gear unit types without and with load sharing. Transmission ratio $i = 7$. Size comparison to scale of gear units with the same output torque.

Gear unit A has one stage, gear unit B has two stages. Both gear units are without load sharing. Gear units C, D, E, F, and G have two stages and are load sharing. The idler gears in gear units C and D have different diameters. In gear units E, F, and G the idler gears of one shaft have been joined to one gear so that they are also considered to be single-stage gear units.

Gear unit C has double load sharing. Uniform load distribution is achieved in the high-speed gear stage by double helical teeth and the axial movability of shaft 1.

In gear unit D the load of the high-speed gear stage is equally shared between three gears which is achieved by the radial movability of the sun gear on shaft 1. In the low-speed gear stage the load is shared six times altogether by means of the double helical teeth and the axial movability of the intermediate shaft.

In order to achieve equal load distribution between the three intermediate gears of gear units E, F, and G the sun gear on shaft 1 mostly is radially movable. The large internal gear is an annulus gear which in the case of gear unit E is connected with shaft 2, and in the case of gear units F and G with the housing. In gear units F and G, web and shaft 2 form an integrated whole. The idler gears rotate as planets around the central axle. In gear unit G, double helical teeth and axial movability of the idler gears guarantee equal load distribution between six branches.

1.4.3.1 Load value

By means of load value B_L , it is possible to compare cylindrical gear units with different ultimate stress values of the gear materials with each other in the following examinations.

According to /14/, the load value is the tooth peripheral force F_u referred to the pinion pitch diameter d_w and the carrying facewidth b , i.e.

$$B_L = \frac{F_u}{b \cdot d_w} \quad (25)$$

The permissible load values of the meshings of the cylindrical gear units can be computed from the pitting resistance by approximation, as shown in /15/ (see section 1.3.4), using the following formula:

$$B_L \approx 7 \cdot 10^{-6} \frac{u}{u+1} \frac{\sigma_{Hlim}^2}{K_A \cdot S_H^2} \quad (26)$$

with B_L in N/mm^2 and allowable stress number for contact stress (pitting) σ_{Hlim} in N/mm^2 as well as gear ratio u , application factor K_A and factor of safety from pitting S_H . The value of the gear ratio u is always greater than 1, and is negative for internal gear pairs (see table 3).

Load value B_L is a specific quantity and independent of the size of the cylindrical gear unit. The following applies for practically executed gear units: cylindrical gears out of case hardening steel $B_L = 4 \dots 6 N/mm^2$; cylindrical gears out of quenched and tempered steel $B_L = 1 \dots 1.5 N/mm^2$; planetary gear stages with annulus gears out of quenched and tempered steel, planet gears and sun gears out of case hardening steel $B_L = 2.0 \dots 3.5 N/mm^2$.

Cylindrical Gear Units

Gear Unit Types

1.4.3.2 Referred torques

In figure 22, referred torques for the gear units shown in figure 21 are represented, dependent on the transmission ratio i . Further explanations are given in table 7. The torque T_2 is referred to the construction dimension D when comparing the sizes, to the weight of the gear unit G when

comparing the weights, and to the generated surface A of the pitch circle cylinders when comparing the gear teeth surfaces. Gear unit weight G and gear teeth surface A (= generated surface) are measures for the manufacturing cost. The higher a curve, in figure 22, the better the respective gear unit in comparison with the others.

Comparison criteria	Definition	Dimension	Units of the basic details
Size	$\delta = \frac{T_2}{D^3 B_L}$	$\frac{m}{mm}$	T_2 in Nm B_L in N/mm ²
Weight	$\gamma = \frac{T_2}{G B_L}$	$\frac{m \text{ mm}^2}{kg}$	D in mm G in kg
Gear teeth surface	$\alpha = \frac{T_2}{A^{3/2} B_L}$	$\frac{mm^2}{m^2}$	A in m ²

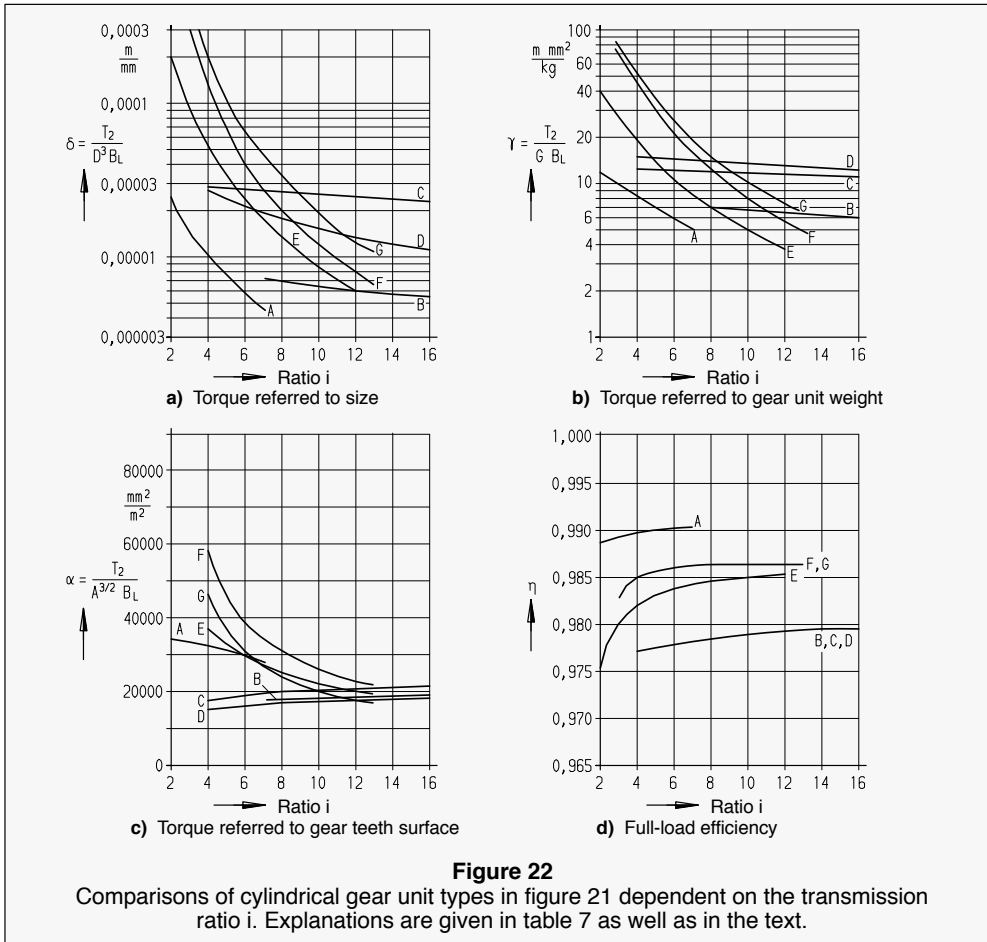

Figure 22

Comparisons of cylindrical gear unit types in figure 21 dependent on the transmission ratio i . Explanations are given in table 7 as well as in the text.

For all gear units explained in figures 21 and 22, the same prerequisites are valid. For all gear units, the construction dimension D is larger than the sum of the pitch diameters by the factor 1.15. Similar definitions are valid for gear unit height and width. Also the wall thickness of the housing is in a fixed relation to the construction dimension $D/15$.

With a given torque T_2 and with a load value B_L computed according to equation (26), the construction dimension D , the gear unit weight G , and the gear teeth surface A can be determined by approximation by figure 22 for a given transmission ratio i . However, the weights of modular-type gear units are usually higher, since the housing dimensions are determined according to different points of view.

Referred to size and weight, planetary gear units F and G have the highest torques at small ratios i . For ratios $i < 4$, the planet gear becomes the pinion instead of the sun gear. Space requirement and load carrying capacity of the planet gear bearings decrease considerably. Usually, the planet gear bearings are arranged in the planet carrier for ratio $i < 4.5$.

Gear units C and D, which have only external gears, have the highest torque referred to size and weight for ratios above $i \approx 7$. For planetary gear units, the torque referred to the gear teeth surface is more favourable only in case of small ratios, if compared with other gear units. It is to be taken into consideration, however, that internal gears require higher manufacturing expenditure than external gears for the same quality of manufacture.

The comparisons show that there is no optimal gear unit available which combines all advantages over the entire transmission ratio range. Thus, the output torque referred to size and weight is the most favourable for the planetary gear unit, and this all the more, the smaller the transmission ratio in the planetary gear stage. With increasing ratio, however, the referred torque decreases considerably. For ratios above $i = 8$, load sharing gear units having external gears only are more favourable because with increasing ratio the referred torque decreases only slightly.

With regard to the gear teeth surface, planetary gear units do not have such big advantages if compared to load sharing gear units having external gears only.

1.4.3.3 Efficiencies

When comparing the efficiencies, figure 22d, only the power losses in the meshings are taken into consideration. Under full load, they come to approx. 85% of the total power loss for common

cylindrical gear units with rolling bearings. The efficiency as a quantity of energy losses results from the following relation with the input power at shaft 1 and the torques T_1 and T_2

$$\eta = \left| \frac{1}{i} \frac{T_2}{T_1} \right| \quad (27)$$

All gear units shown in figure 21 are based on the same coefficient of friction of tooth profile $\mu_z = 0.06$. Furthermore, gears without addendum modification and numbers of teeth of the pinion $z = 17$ are uniformly assumed for all gear units /15/, so that a comparison is possible.

The single stage gear unit A has the best efficiency. The efficiencies of the two stage gear units B, C, D, E, F, and G are lower because the power flow passes two meshings. The internal gear pairs in gear units E, F, and G show better efficiencies owing to lower sliding velocities in the meshings compared to gear units B, C, and D which only have external gear pairs.

The lossfree coupling performance of planetary gear units F and G results in a further improvement of the efficiency. It is therefore higher than that of other comparable load sharing gear units. For higher transmission ratios, however, more planetary gear stages are to be arranged in series so that the advantage of a better efficiency compared to gear units B, C, and D is lost.

1.4.3.4 Example

Given: Two planetary gear stages of type F arranged in series, total transmission ratio $i = 20$, output torque $T_2 = 3 \cdot 10^6$ Nm, load value $B_L = 2.3$ N/mm². A minimum of weight is approximately achieved by a transmission ratio division of $i = 5 \cdot 4$ of the HS and LS stage. At $\gamma_1 = 30$ m mm²/kg and $\gamma_2 = 45$ m mm²/kg according to figure 22 b, the weight for the HS stage is approximately 10.9 t and for the LS stage approximately 30 t, which is a total 40.9 t. The total efficiency according to figure 22 d is $\eta = 0.986 \cdot 0.985 = 0.971$.

In comparison to a gear unit of type D with the same transmission ratio $i = 20$ and the same output torque $T_2 = 3 \cdot 10^6$ Nm, however, with a better load value $B_L = 4$ N/mm² this gear unit has a weight of 68.2 t according to figure 22 with $\gamma = 11$ m mm²/kg and is thus heavier by 67%. The advantage is a better efficiency of $\eta = 0.98$. The two planetary gear stages of type F together have a power loss which is by 45% higher than that of the gear unit type D. In addition, there is not enough space for the rolling bearings of the planet gears in the stage with $i = 4$.

Cylindrical Gear Units

Noise Emitted by Gear Units

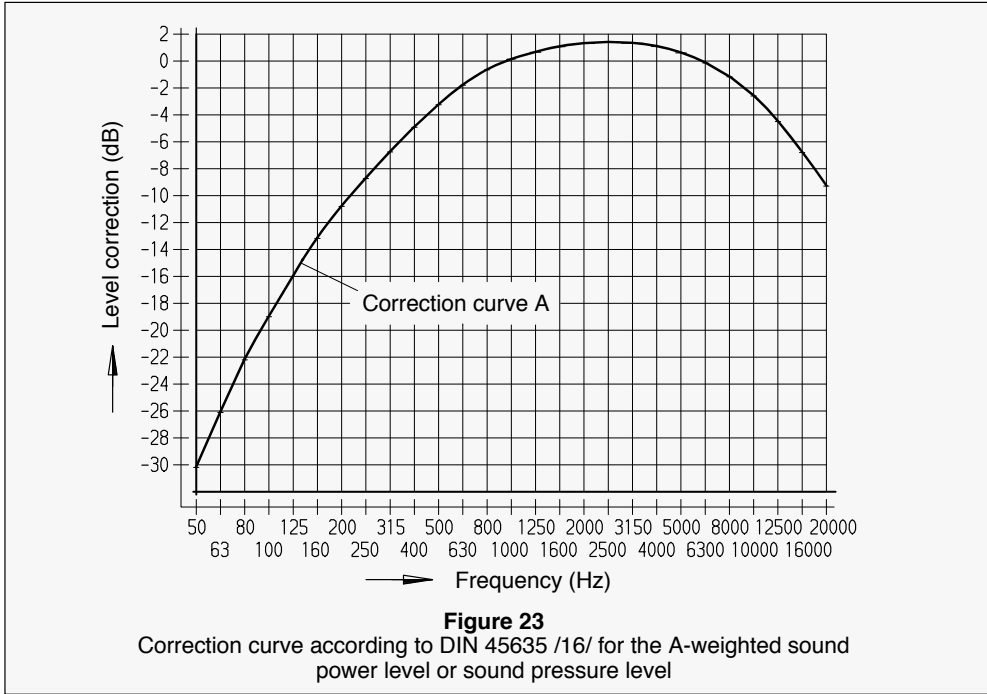

1.5 Noise emitted by gear units

1.5.1 Definitions

Noise emitted by a gear unit – like all other noises – is composed of tones having different frequencies f .

Measure of intensity is the sound pressure p which is the difference between the highest (or lowest) and the mean pressure in a sound wave detected by the human ear.

The sound pressure can be determined for a single frequency or – as a combination – for a frequency range (single-number rating). It is dependent on the distance to the source of sound.

In general, no absolute values are used but amplification or level quantities in bel (B) or decibel (dB).

Conversion of the absolute values is made for the sound pressure using equation

$$L_p = 20 \cdot \log(p/p_0) \text{ [dB]} \quad (28)$$

and for the sound power using equation

$$L_W = 10 \cdot \log(P/P_0) \text{ [dB]} \quad (29)$$

The reference values (e.g. p_0 and P_0) have been determined in DIN EN ISO 1683. For the sound pressure, the threshold of audibility of the human ear at 2 kHz has been taken as reference value ($p_0 = 2 \cdot 10^{-5}$ Pa). For the conversion of the sound power applies ($P_0 = 10^{-12}$ W).

In order to take into consideration the different sensitivities of the human ear at different frequencies, the physical sound pressure value at the different frequencies is corrected according to rating curve A, see figure 23.

A-weighted quantities are marked by subscript "A" (e.g. sound pressure L_p ; A-weighted sound pressure L_{pA}).

Apart from sound pressures at certain places, sound powers and sound intensities of a whole system can be determined.

From the gear unit power a very small part is turned into sound power. This mainly occurs in the meshings, but also on bearings, fan blades, or by oil movements. The sound power is transmitted from the sources to the outside gear unit surfaces mainly by structure-borne noise (material vibrations). From the outside surfaces, air borne noise is emitted.

Cylindrical Gear Units

Noise Emitted by Gear Units

The sound power L_{WA} is the A-weighted sound power emitted from the source of sound and thus a quantity independent of the distance. The sound power can be converted to an average sound pressure for a certain place. The sound pressure decreases with increasing distance from the source of sound.

The sound intensity is the flux of sound power through a unit area normal to the direction of propagation. For a point source of sound it results from the sound power L_W divided by the spherical enveloping surface $4 \cdot \pi \cdot r^2$, concentrically enveloping the source of sound. Like the sound pressure, the sound intensity is dependent on the distance to the source of sound, however, unlike the sound pressure it is a directional quantity.

The recording instrument stores the sound pressure or sound intensity over a certain period of time and writes the dB values in frequency ranges (bands) into the spectrum (system of coordinates).

Very small frequency ranges, e.g. 10 Hz or 1/12 octaves are termed narrow bands, see figure 24.

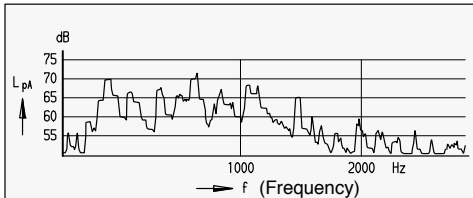

Figure 24
Narrow band frequency spectrum for L_{pA}
(A-weighted sound pressure level)
at a distance of 1 m from a gear unit.

Histograms occur in the one-third octave spectrum and in the octave spectrum, see figures 25 and 26. In the one-third octave spectrum (spectrum with 1/3 octaves), the bandwidth results from

$$f_o / f_u = \sqrt[3]{2}, \text{ i.e. } f_o / f_u = 1.26,$$

$$f_o = f_m \cdot 1.12 \text{ and } f_u = f_m / 1.12;$$

f_m = mean band frequency, f_o = upper band frequency, f_u = lower band frequency. In case of octaves, the upper frequency is twice as big as the lower one, or
 $f_o = f_m \cdot 1.41$ and $f_u = f_m / 1.41$.

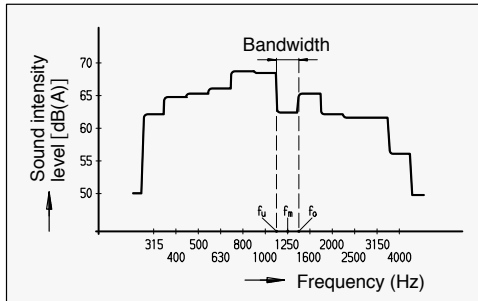

Figure 25
One-third octave spectrum of a gear unit
(sound intensity level, A-weighted)

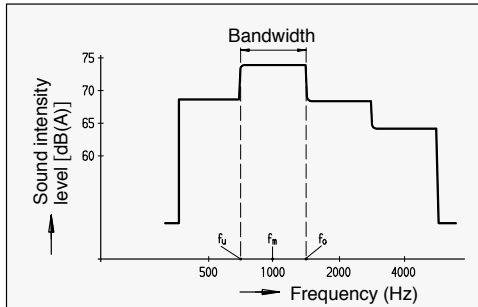

Figure 26
Octave spectrum of a gear unit
(sound intensity level, A-weighted)

The total level (resulting from logarithmic addition of individual levels of the recorded frequency range) is a single-number rating. The total level is the common logical value for gear unit noises. The sound pressure level is valid for a certain distance, in general 1 m from the housing surface as an ideal parallelepiped.

1.5.2 Measurements

The main noise emission parameter is the sound power level.

1.5.2.1 Determination via sound pressure

DIN 45635 Part 1 and Part 23 describe how to determine the sound power levels of a given gear unit /16/. For this purpose, sound pressure levels L_{pA} are measured at fixed points surrounding the gear unit and converted into sound power levels L_{WA} . The measurement surface ratio L_S is an auxiliary quantity which is dependent on the sum of the measurement surfaces. When the gear unit is placed on a reverberant base, the bottom is not taken into consideration, see example in figure 27.

Cylindrical Gear Units

Noise Emitted by Gear Units

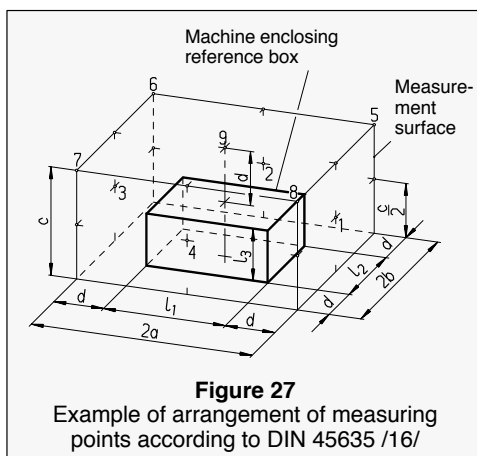

Figure 27
Example of arrangement of measuring points according to DIN 45635 /16/

In order to really detect the noise radiated by the gear unit alone, corrections for background noise and environmental influences are to be made. They are estimated by measuring background noises (caused by noise radiating machines in the vicinity) and the characteristics of the room (reverberation time, resonances in the room) and are used as correction values in the sound power calculation. If the background noises are too loud (limit values of correction factors are achieved), this method can no longer be used because of insufficient accuracy.

1.5.2.2 Determination via sound intensity

The gear unit surface is scanned manually all around at a distance of, for instance, 10 cm, by means of a special measuring device containing two opposing microphones. The mean of the levels is taken via the specified time, e.g. two minutes. The sound intensity determined in this way is the average sound energy flow penetrating the scanned surface. The sound power can be determined by multiplying the sound intensity by the scanned surface area.

This method has been standardized in DIN EN ISO 9614-2. Because of the special property of the measuring device – to determine the direction of sound incidence – it is very easy to eliminate background noises.

The results correspond to the values as determined in accordance with DIN 45635. As a rule, the sound intensity method is more accurate (less measurement uncertainty) because it is less insensitive to noises and can also be used in case of loud background noises (e.g. in industrial plants).

1.5.3 Prediction

It is not possible to exactly calculate in advance the sound power level of a gear unit to be made. However, one can base the calculations on experience. In the VDI guidelines 2159 /17/, for example, reference values are given. Gear unit manufacturers, too, mostly have own records.

The VDI guidelines are based on measurements carried out on a large number of industrial gear units. Main influence parameters for gear unit noises are gear unit type, transmitted power, manufacturing quality, and speed. In VDI 2159, a distinction is made between cylindrical gear units with rolling bearings, see figure 28, cylindrical gear units with sliding bearings (high-speed gear units), bevel gear and bevel-helical gear units, planetary gear units, and worm gear units. Furthermore, information on speed variators can be found in the guidelines.

Figure 28 exemplary illustrates a characteristic diagram of emissions for cylindrical gear units. Similar characteristic diagrams are also available for the other gear unit types mentioned. Within the characteristic diagrams, 50%- and 80%-lines are drawn. The 80%-line means, for example, that 80% of the recorded industrial gear units radiate lower noises.

The lines are determined by mathematical equations. For the 80%-lines, the equations according to VDI 2159 are:

Gear units	Total sound power level L_{WA}
Cylindrical gear units (rolling bearings)	$77.1 + 12.3 \cdot \log P / \text{kW} \text{ (dB)}$
Cylindrical gear units (sliding bearings)	$85.6 + 6.4 \cdot \log P / \text{kW} \text{ (dB)}$
Bevel gear and bevel-helical gear units	$71.7 + 15.9 \cdot \log P / \text{kW} \text{ (dB)}$
Planetary gear units	$87.7 + 4.4 \cdot \log P / \text{kW} \text{ (dB)}$
Worm gear units	$65.0 + 15.9 \cdot \log P / \text{kW} \text{ (dB)}$

For restrictions, see VDI 2159.

Cylindrical Gear Units

Noise Emitted by Gear Units

Type: Cylindrical gear units with external teeth mainly (> 80%) having the following characteristic features:

Housing: Cast iron housing

Bearing arrangement: Rolling bearings

Lubrication: Dip lubrication

Installation:

Rigid on steel or concrete

Power rating: 0.7 up to 2400 kW

Input speed (= max. speed):

1000 up to 5000 min⁻¹ (mostly 1500 min⁻¹)

Max. circumferential speed:

1 up to 20 ms⁻¹

Output torque:

100 up to 200 000 Nm

No. of gear stages: 1 to 3

Information on gear teeth:

HS gear stage with helical teeth

(β = 10° up to 30°), hardened, fine-machined, DIN quality 5 to 8

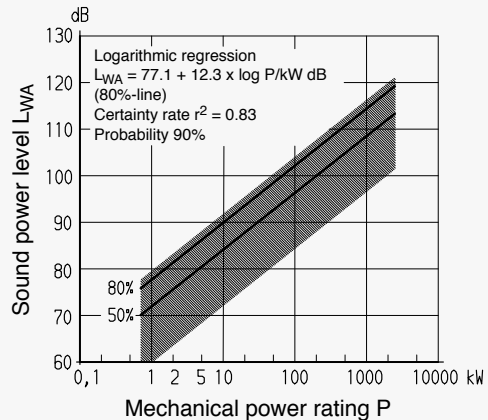

Figure 28

Characteristic diagram of emissions for cylindrical gear units (industrial gear units) acc. to VDI 2159 /17/

To calculate a sound pressure level from the given sound power values a measuring method is used comparable with that described in DIN 45635. It is assumed that the sound energy is uniquely radiated from the object in all directions and can propagate undisturbed (free sound propagation). This assumption results in the so-called measurement surface sound pressure level, the average sound pressure at a determined distance to the gear unit.

The measurement surface sound pressure level L_{pA} at a distance of 1 m is calculated from the total sound power level

$$L_{pA} = L_{WA} - L_S \text{ (dB)} \quad (30)$$

$$L_S = 10 \cdot \log S \text{ (dB)} \quad (31)$$

S = Sum of the hypothetical surfaces (m²) enveloping the gear unit at a distance of 1 m (ideal parallelepiped)

Example of information for $P = 100$ kW in a two-stage cylindrical gear unit of size 200 (centre distance in the 2nd gear stage in mm), with rolling bearings, of standard quality:

“The sound power level, determined in accordance with DIN 45635 (sound pressure measurement) or according to the sound intensity measurement method, is 102 ± 3 dB (A). Room and connection influences have not been taken into consideration. If it is agreed that measurements are to be made they will be carried out on the manufacturer’s test stand.”

Note:

For this example, a measurement surface sound pressure level of $102 - 13.2 \approx 89$ dB (A), tolerance ± 3 dB, is calculated at a distance of 1 m with a measurement surface $S = 21$ m² and a measurement surface ratio $L_S = 13.2$ dB. (Error of measurement according to DIN EN ISO 9614-2 for measurements in the industrial area with accuracy grade 2.)

Individual levels in a frequency spectrum cannot safely be predicted for gear units because of the multitude of influence parameters.

1.5.4 Possibilities of influencing

With the selection of other than standard geometries and with special tooth modifications (see section 1.2.5), gear unit noises can be positively influenced. In some cases, such a procedure results in a reduction in the performance (e.g. module reduction) for the same size, in any case, however, in special design and manufacturing expenditure. Housing design, distribution of masses, type of rolling bearing, lubrication and cooling are also important.

Sometimes, the only way is to enclose the gear units which makes possible that the total level is reduced by 10 to 25 dB, dependent on the conditions.

Attention has to be paid to it, that no structure-borne noise is radiated via coupled elements (couplings, connections) to other places from where then airborne noise will be emitted.

A sound screen does not only hinder the propagation of airborne noise but also the heat dissipation of a gear unit, and it requires more space.

Table of Contents Section 11

Shaft Couplings	Page
General Fundamental Principles	116
Torsionally Rigid Couplings, Flexible Pin Couplings Flexible Claw Couplings	117
Highly Flexible Ring Couplings, Highly Flexible Rubber Tyre Couplings Highly Flexible Rubber Disk Couplings, Flexible Pin and Bush Couplings	118
All-steel Couplings, Torque Limiters High-speed Couplings, Composite Couplings	119
Miniature Couplings, Gear Couplings Universal Gear Couplings, Multiple Disk Clutches	120
Fluid Couplings, Overrunning Clutches, Torque Limiters	121
Couplings for Pump Drives	122
Coupling Systems for Railway Vehicles	123
Coupling Systems for Wind Turbines	124

Shaft Couplings

General Fundamental Principles

Rigid and Torsionally Flexible Couplings

2. Shaft couplings

2.1 General fundamental principles

In mechanical equipment, drives are consisting of components like prime mover, gear unit, shafts, and driven machine. Such components are connected by couplings which have the following tasks:

- Transmitting motion of rotation and torques;
- Compensating shaft misalignments (radial, axial, angular);
- Reducing the torsional vibration load, influencing and displacing the resonant ranges;

- Damping torque and speed impulses;
- Interrupting the motion of rotation (clutches);
- Limiting the torque (torque limiters);
- Sound isolation;
- Electrical insulation.

The diversity of possible coupling variants is shown in the overview in figure 29. A distinction is made between the two main groups: couplings and clutches.

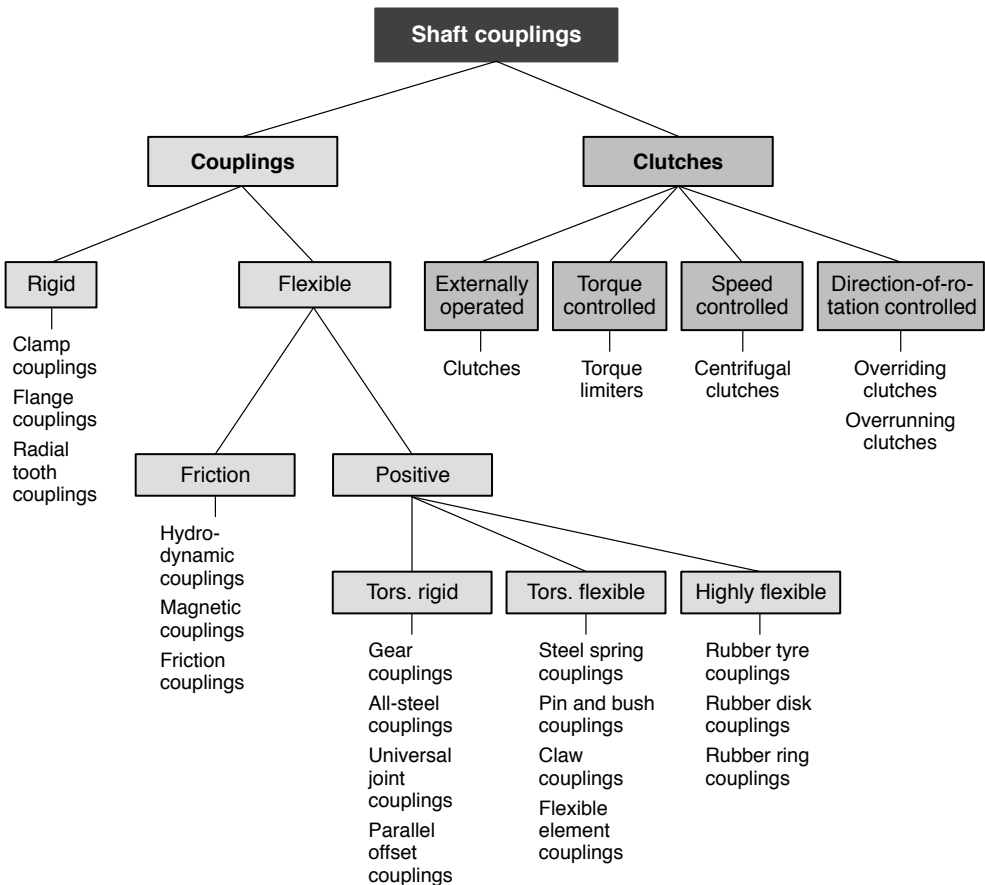

Figure 29
Overview of possible shaft coupling designs

Shaft Couplings

Torsionally Rigid Couplings, Flexible Pin Couplings
Flexible Claw Couplings

Flange couplings

Torsionally rigid couplings

Connect two shafts ends torsionally rigid and exactly centered to each other • designed for heavily stressed shafts • not subject to wear and require no maintenance • suitable for both directions of rotation

Nominal torque: 1 300 ... 180 000 Nm

on request

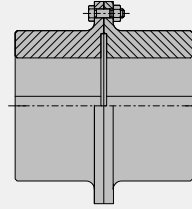

N-EUPEX

Flexible pin couplings

Universally applicable coupling for compensating shaft displacements • maximum operational reliability owing to **fail-safe** device • suitable for plug-in assembly and simplified assembly of the design consisting of three parts

Nominal torque: 19 ... 62 000 Nm

Brochure MD 10.1

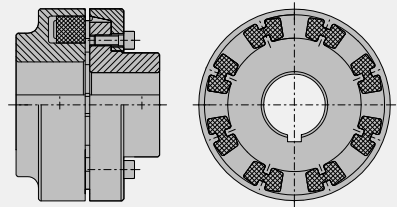

N-EUPEX-DS

Flexible pin couplings

Disconnecting driving and driven machines upon failure of flexible elements (**without fail-safe device**) • universally applicable since combination with all parts of the N-EUPEX product range is possible

Nominal torque: 19 ... 21 200 Nm

Brochure MD 10.1

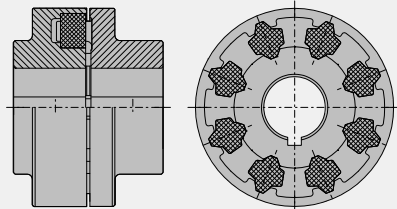

BIPEX

Flexible claw couplings

Fail-safe universal coupling • very compact design, high power capacity • very well suitable for plug-in assembly and assembly into bell housing • also with Taper bush for easy assembly and bore adaptation

Nominal torque: 13.5 ... 3 700 Nm

Brochure MD 10.1

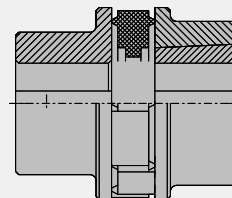

Shaft Couplings

Highly Flexible Ring Couplings, Highly Flexible Rubber Tyre Couplings
Highly Flexible Rubber Disk Couplings, Flexible Pin and Bush Couplings

ELPEX

Highly flexible ring couplings

Coupling without torsional backlash • can be used for large shaft misalignments • suitable for high dynamic loads, good damping properties

Nominal torque: 1 600 ... 90 000 Nm

Brochure MD10.1

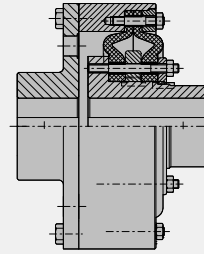

ELPEX-B

Highly flexible rubber tyre couplings

Coupling without torsional backlash • compensating very large shaft misalignments • the rubber tyre can be easily replaced without the need to move the coupled machines • easy mounting on the shafts to be connected by means of Taper bushes

Nominal torque: 24 ... 14 500 Nm

Brochure MD10.1

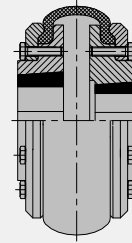

ELPEX-S

Highly flexible rubber disk couplings

For connecting machines having a very non-uniform torque characteristic • very easy plug-in assembly • replacement of rubber disk element is possible without the need to move the coupled machines • flange with dimensions acc. to SAE J620d

Nominal torque: 330 ... 63 000 Nm

Brochure MD10.1

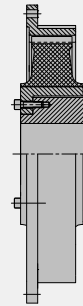

RUPEX

Flexible pin and bush couplings

Fail-safe universal coupling for medium up to high torques, absorbing large shaft displacements • compact design, low weights and mass moments of inertia • suitable for plug-in assembly

Nominal torque: 200 ... 1 300 000 Nm

Brochure MD10.1

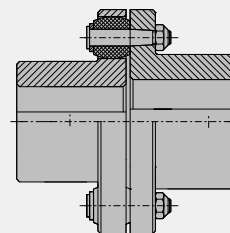

Shaft Couplings

All-steel Couplings, Torque Limiters

High-speed Couplings, Composite Couplings

ARPEX - ARS (ARF / ARC / ARW)

All-steel couplings

Torsionally rigid coupling without clearance • compensates radial, angular and axial shaft displacements by means of two flexible disc packs • packs made out of stainless spring steel • easy assembly of coupling due to compact disc packs • modular system: many standard types by combination of standard components

Nominal torque: 92 ... 1 450 000 Nm

Brochure MD10.1

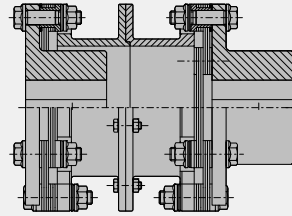

ARPEX - AKR

Torque limiters

On reaching the preset disconnecting torque, the torque limiter separates the coupled drive components both during slow and fast rising torques • after the disengagement process the coupling halves are out of contact, so that a wear-free running down can be realized

Nominal torque: 10 ... 75 000 Nm

Brochure MD10.11

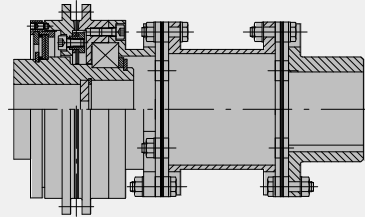

ARPEX - ART

High-speed couplings

Were designed for the energy and petrochemical industries and marine propulsion drives • are used for all high-speed purposes where reliable power transmission is required even with unavoidable shaft misalignment • meet the requirements of API 671

Nominal torque: 1 000 ... 535 000 Nm

Brochure MD10.9

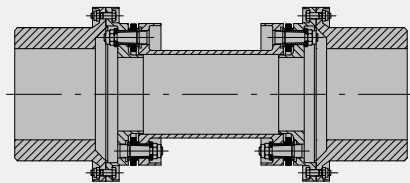

ARPEX - ARS Composite

Composite couplings

Corrosion-resistant, extreme light weight coupling for drives with great shaft distances (e.g. cooling tower fan) • up to 6 metres without centre bearing support • easy to handle and to install • maintenance-free and wear-free • reduced coupling vibrations

Nominal torque: 1 250 ... 7 600 Nm

Brochure MD10.5

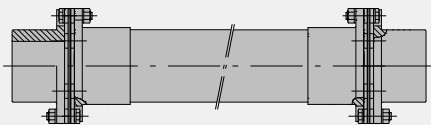

Shaft Couplings

Miniature Couplings, Gear Couplings

Universal Gear Couplings, Multiple Disk Clutches

ARPEX - ARM

Miniature couplings

Designed for applications with very low torques
• fields of application: control systems, machine tools, computer technology, tachometers, measuring and registering systems, printing and packaging machines, stepping and servomotors, test stands

Nominal torque: 5 ... 25 Nm

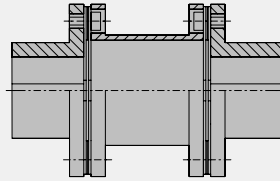

Brochure MD10.10



ZAPEX-ZW

Gear couplings

Double-jointed coupling compensating angular, parallel and axial misalignment of shafts • long-term lubrication is ensured by design measures and by using special seals • small dimensions; can be used for high shock loads • available in many types and variants

Nominal torque: 1 300 ... 7 200 000 Nm

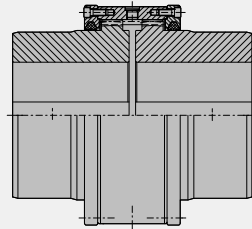

Brochure MD10.1



ZAPEX-ZI

Universal gear couplings

Double-jointed gear coupling with hobbled and crowned external gear teeth and low torsional backlash • largest possible bore range with grease lubricated gear teeth • mounting dimensions in metric and inch measures acc. to international standards

Nominal torque: 850 ... 125 000 Nm

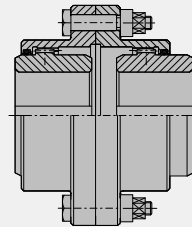

Brochure MD10.1



PLANOX

Multiple disk clutches

Constant torque transmission by means of contact pressure ensured by springs • many applications possible owing to mechanical, electrical, pneumatic or hydraulic disengaging devices • protects drives against overloading

Nominal torque: 10 ... 30 000 Nm

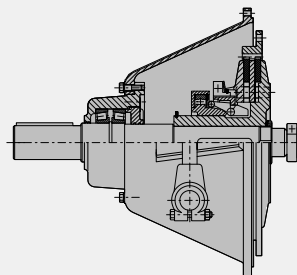

on request

Shaft Couplings

Fluid Couplings, Overrunning Clutches
Torque Limiters

FLUDEX

Fluid couplings

Soft starting without shocks and acceleration of large masses during a load-relieved start of motor • torque limitation during starting and overload • excellent vibration separation and shock damping • torque transmission without wear

Nominal power ratings: 0.5 ... 2 500 kW

Brochure MD10.1

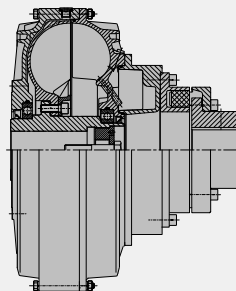

UZWN

Overrunning clutches

Flender overrunning clutches allow to drive shafts and machines first by means of an auxiliary drive at low speed for startup and then by means of the main drive at higher speeds for full-load operation, the auxiliary drive then being shut off by overrunning.

Nominal torque: 9 000 ... 100 000 Nm

Dimensioned drawing M 495

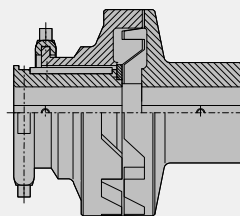

Certified according to directive 94/9/EC (ATEX 95)

This coupling is particularly suitable for the use in hazardous locations

SECUREX

Torque limiters

With SECUREX, Flender provides a unique modular system of mechanical torque limiters. Owing to a variety of possibilities to combine standard components, the functions **Protection from overload** as well as **Compensation of shaft misalignment** can be fulfilled with just one compact unit.

With the development of SECUREX, Flender has concentrated its experiences gained over decades in the fields of both overload protection and compensation of shaft misalignments in one product line.

SECUREX is based on the wide range of Flender's standard couplings of different basic types and on standardized safety elements. With this combination, economical coupling solutions can be realized.

With the modular SECUREX system, Flender has focused on its core competence in the torque range of up to 1,500,000 Nm and benefits from its rich fund of knowledge and experience gained from application- and product-related R&D (e.g. sliding hubs in the wind energy industry, shear pin solutions in rolling mills, torque limiters in extruder applications, etc.).

Brochure K 440

Couplings for pump drives

N-EUPEX

Flexible pin couplings

- Tried and tested drive element in millions of pump drives
- Good value for money, reliable, available world-wide
- Complete application-oriented assortment! In addition to the fail-safe standard design, a variant without fail-safe device is available - especially developed for hazardous locations

Types B / BDS - in two parts

Types A / ADS - in three parts

Types H / HDS - with intermediate sleeve

Certified acc. to directive 94/9/EC (ATEX 95)

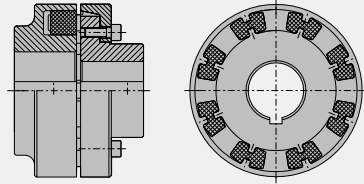

Type A

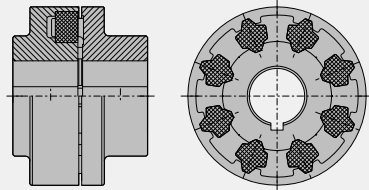

Type BDS

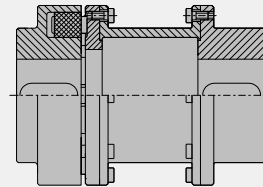

Type H



Katalog MD 10.1

ARPEX - ARP

All-steel couplings

Were specially designed for pump drives

- Meet the requirements of API 610
- Design according to API 671, "NON-SPARKING" and certified acc. to directive 94/9/EC (ATEX 95) also available

Nominal torque: 100 ... 17 000 Nm

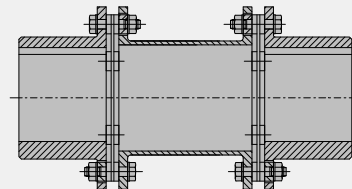

Katalog MD 10.1

Coupling systems for railway vehicles

Input side couplings

Membrane coupling, Type MBG

- All-steel membrane coupling for the connection of motor and gear unit
- Without backlash; compensating relatively small shaft misalignments

Max. nominal torque: 3 425 Nm

Max. shaft diameter: 86 mm

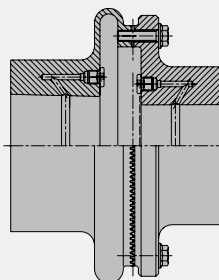

Gear coupling, Type ZBG

- Double-jointed grease lubricated gear coupling between motor and gear unit
- Compensating extremely large shaft misalignments
- Split spacer with crowned gear teeth

Max. nominal torque: 15 000 Nm

Max. shaft diameter: 100 mm

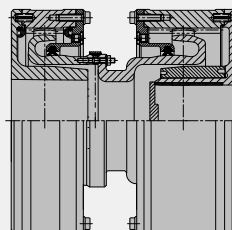

on request

Output side couplings

Articulated joint rubber coupling, Type GKG

- Double-jointed, flexible coupling without backlash, between axle drive and driving wheel shaft
- Low wear and low maintenance
- Compensating extremely large shaft misalignments, with low restoring forces

Max. nominal torque: 13 440 Nm

Max. shaft diameter: 260 mm

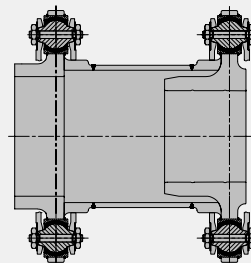

on request

Coupling systems for wind turbines

FLUDEX

Fluid couplings in combination with other couplings

- Fluid coupling with slip between 2 and 3%. Peak torques caused by gusts of wind are compensated
- Combination with RUPEX coupling for small shaft misalignments
- Combination with articulated joint rubber coupling or ARPEX coupling for large shaft misalignments

on request

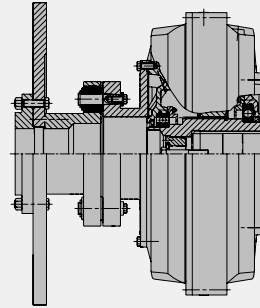

Articulated joint rubber couplings Type GKGW with brake disk

- Rubber-elastic ball bearings for extremely large shaft misalignments between gear unit and generator
- Very low restoring forces
- Electrically insulating and structure-borne noise absorbing
- Wearing parts and coupling can be removed without the need to move the generator
- Optional with torque-limiting slip hub

on request

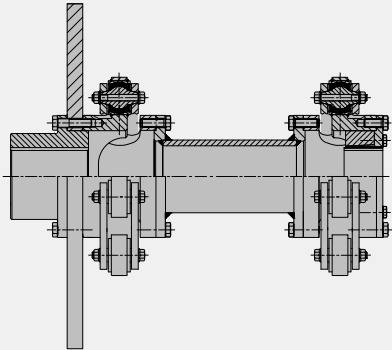

ARPEX

All-steel couplings

- Design with hexagonal or square disc pack for very large shaft misalignments
- Optionally with slip hub for limiting the torque load in case of generator short-circuit
- Light spacer out of glass-fibre compound material for lightning insulation
- Conical bolt connection of disc packs for easy assembly

on request

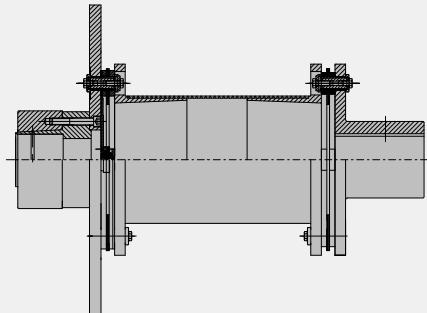

Table of Contents Section 12

Vibrations	Page
Symbols and Units	126
General Fundamental Principles	127 – 129
Solution Proposal for Simple Torsional Vibrators	129 + 130
Solution of the Differential Equation of Motion	130 + 131
Formulae for the Calculation of Vibrations	131
Mass	131
Mass Moment of Inertia	131
Terms, Symbols, and Units	132
Determination of Stiffness	133
Overlaying of Different Stiffnesses	134
Conversions	134
Natural Frequencies	134
Evaluation of Vibrations	135 + 136

Vibrations

Symbols and Units

a	m	Length of overhanging end
A	m ²	Cross-sectional area
A	m, rad	Amplitude of oscillation
A _D ; A _e		Damping energy; elastic energy
c	Nm/rad	Torsional stiffness
c'	N/m	Translational stiffness; bending stiffness
d	m	Diameter
d _i	m	Inside diameter
d _a	m	Outside diameter
D	–	Attenuation ratio (Lehr's damping)
D _m	m	Mean coil diameter (coil spring)
e =	2.718	Euler's number
E	N/m ²	Modulus of elasticity
f, f _e	Hz	Frequency; natural frequency
f	m	Deformation
F	N	Force
F (t)	N	Time-variable force
G	N/m ²	Shear modulus
i	–	Transmission ratio
i _F	–	Number of windings (coil spring)
I _a	m ⁴	Second axial moment of area
I _p	m ⁴	Second polar moment of area
J, J _i	kgm ²	Mass moment of inertia
J*	kgm ²	Reduced mass moment of inertia of a two-mass vibration generating system
k	Nms/rad	Viscous damping in case of torsional vibrations
k'	Ns/m	Viscous damping in case of translational and bending vibrations
l	m	Length; distance between bearings
m, m _i	kg	Mass
M (t)	Nm	Time-variable excitation moment
M ₀	Nm	Amplitude of moment
M ₀ *	Nm	Reduced amplitude of moment of a two-mass vibration generating system
n _e	1/min	Natural frequency (vibrations per minute)
n ₁ ; n ₂	min ⁻¹	Input speed; output speed
q	–	Influence factor for taking into account the mass of the shaft when calculating the natural bending frequency
t	s	Time

T	s	Period of a vibration
T	Nm	Torque
V	m ³	Volume
V	–	Magnification factor; Dynamic/static load ratio
x	m	Displacement co-ordinate (translational, bending)
\hat{x}	m	Displacement amplitude
α	rad	Phase angle
γ	rad	Phase angle with free vibration
δ	1/s	Damping constant
ε	rad	Phase displacement angle with forced vibration
η	–	Excitation frequency/natural frequency ratio
λ _i	–	Inherent value factor for i-th natural frequency
Λ	–	Logarithmic decrement
π =	3.14159	Peripheral/diameter ratio
ρ	kg/m ³	Specific density
φ, φ _i	rad	Angle of rotation
$\hat{\phi}$	rad	Angular amplitude of a vibration
$\dot{\phi}$	rad/s	Angular velocity (first time derivation of φ)
$\ddot{\phi}$	rad/s ²	Angular acceleration (second time derivation of φ)
φ _h	rad	Vibratory angle of the free vibration (homogeneous solution)
φ _p	rad	Vibratory angle of the forced vibration (particular solution)
$\hat{\phi}_p$	rad	Angular amplitude of the forced vibration
$\hat{\phi}_{stat}$	rad	Angular amplitude of the forced vibration under load (φ = 0)
ψ	–	Damping coefficient acc. to DIN 740 /18/
ω	rad/s	Angular velocity, natural radian frequency of the damped vibration
ω ₀	rad/s	Natural radian frequency of the undamped vibration
Ω	rad/s	Radian frequency of the excitation on vibration

Note: The unit "rad" (= radian) may be replaced with "1".

3. Vibrations

3.1 General fundamental principles

Vibrations are more or less regularly occurring temporary variations of state variables. The state of a vibrating system can be described by suitable variables, such as displacement, angle, velocity, pressure, temperature, electric voltage/current, and the like.

The simplest form of a mechanical vibrating system consists of a mass and a spring with fixed ends, the mass acting as kinetic energy store

and the spring as potential energy store, see figure 30. During vibration, a periodic conversion of potential energy to kinetic energy takes place, and vice versa, i.e. the kinetic energy of the mass and the energy stored in the spring are converted at certain intervals of time. Dependent on the mode of motion of the mass, a distinction is made between translational (bending) and torsional vibrating systems as well as coupled vibrating systems in which translational and torsional vibrations occur at the same time, influencing each other.

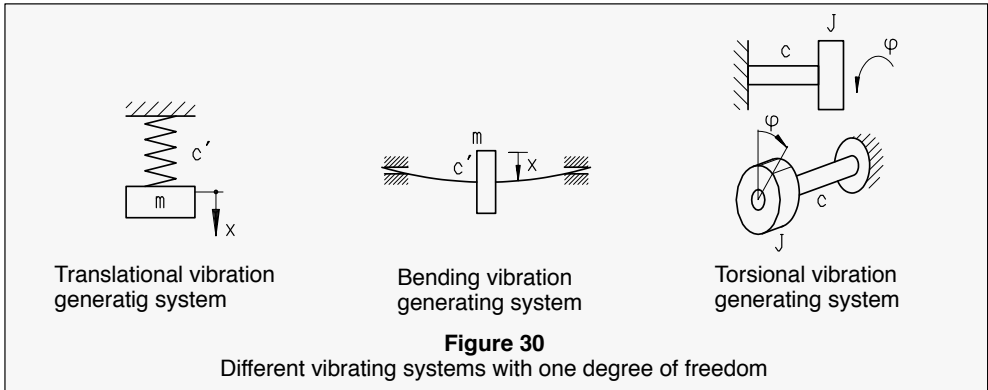

Further, a distinction is made between free vibrations and externally forced vibrations, and whether the vibration takes place without energy losses (undamped) or with energy losses (damped).

A vibration is free and undamped if energy is neither supplied nor removed by internal friction so that the existing energy content of the vibration is maintained. In this case the system carries out steady-state natural

vibrations the frequency of which is determined only by the characteristics of the spring/mass system (natural frequency), figure 32 a.

The vibration variation with time x can be described by the constant amplitude of oscillation A and a harmonic function (sine, cosine) the arguments of which contain natural radian frequency $\omega = 2 \cdot \pi \cdot f$ (f = natural frequency in Hertz) and time, see figure 31.

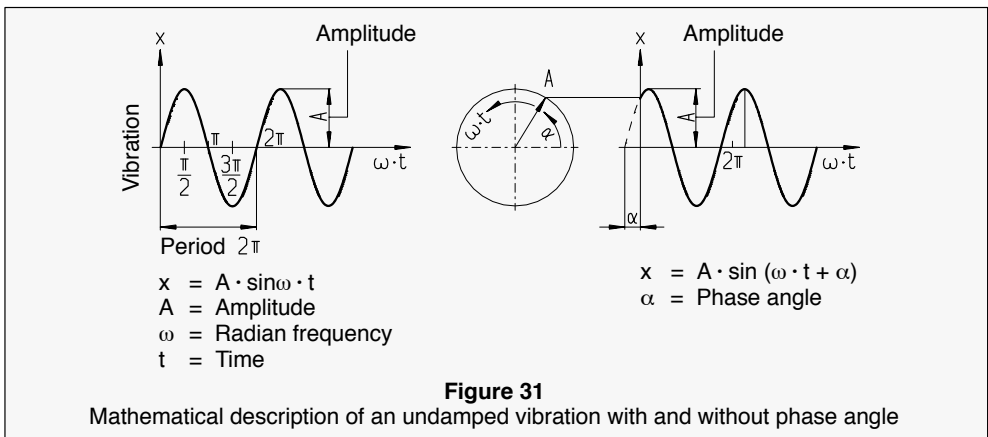

A damped vibration exists, if during each period of oscillation a certain amount of vibrational energy is removed from the vibration generating system by internal or external friction. If a constant viscous damping (Newton's friction) exists, the amplitudes of oscillation decrease in accordance with a geometric progression, figure 32 b. All technical vibration generating systems are subject to more or less strong damping effects.

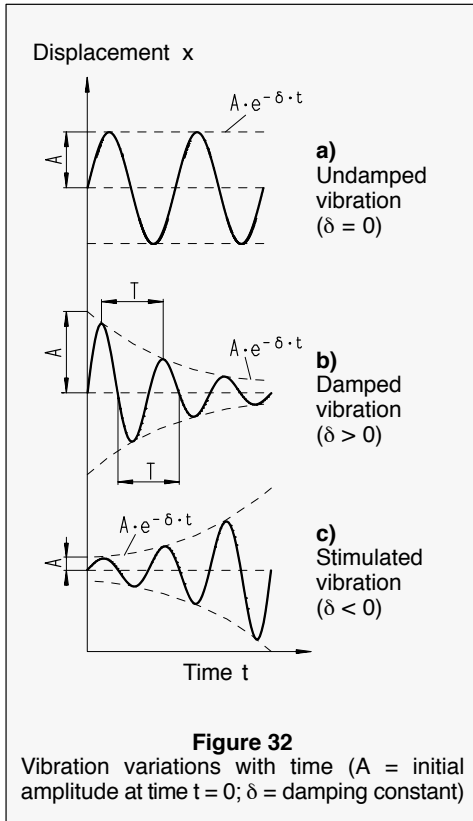

If the vibrating system is excited by a periodic external force $F(t)$ or moment $M(t)$, this is a forced or stimulated vibration. With the periodic external excitation force, energy can be supplied to or removed from the vibrating system.

After a building-up period, a damped vibrating system does no longer vibrate with its natural frequency but with the frequency of the external excitation force.

Resonance exists, when the applied frequency is at the natural frequency of the system. Then, in undamped systems the amplitudes of oscillation grow at an unlimited degree, figure 32c. In damped systems, the amplitude of oscillation

grows until the energy supplied by the excitation force and the energy converted into heat by the damping energy are in equilibrium. Resonance points may lead to high loads in the components and therefore are to be avoided or to be quickly traversed (example: natural bending frequency in high-speed gear units).

The range of the occurring amplitudes of oscillation is divided by the resonance point (natural frequency = excitation frequency, critical vibrations) into the subcritical and supercritical oscillation range. As a rule, for technical vibrating systems (e.g. drives), a minimum frequency distance of 15% or larger from a resonance point is required.

Technical vibrating systems often consist of several masses which are connected with each other by spring or damping elements. Such systems have as many natural frequencies with the corresponding natural vibration modes as degrees of freedom of motion. A free, i.e. unfixed torsional vibration system with n masses, for instance, has $n-1$ natural frequencies. All these natural frequencies can be excited to vibrate by periodic external or internal forces, where mostly only the lower natural frequencies and especially the basic frequency (first harmonic) are of importance.

In technical drive systems, vibrations are excited by the following mechanisms:

a) From the input side:

Starting processes of electric motors, system short circuits, Diesel and Otto engines, turbines, unsteady processes, starting shock impulses, control actions.

b) From transmitting elements:

Meshing, unbalance, universal-joint shaft, alignment error, influences from bearings.

c) From the output side:

Principle of the driven machine, uniform, non-uniform, e.g. piston compressor, propeller.

As a rule, periodic excitation functions can be described by means of sine or cosine functions and the superpositions thereof. When analysing vibration processes, a Fourier analysis may often be helpful where periodic excitation processes are resolved into fundamental and harmonic oscillations and thus in comparison with the natural frequencies of a system show possible resonance points.

In case of simple vibrating systems with one or few (maximum 4) masses, analytic solutions for the natural frequencies and the vibration variation with time can be given for steady excitation. For unsteady loaded vibrating

Vibrations

General Fundamental Principles

Solution Proposal for Simple Torsional Vibrators

systems with one or more masses, however, solutions can be calculated only with the aid of numerical simulation programmes. This applies even more to vibrating systems with non-linear or periodic variable parameters (non-linear torsional stiffness of couplings; periodic meshing stiffnesses). With EDP programmes, loads with steady as well as unsteady excitation can be simulated for complex vibrating systems (linear, non-linear, parameter-excited) and the results be represented in the form of frequency analyses, load as a function of time, and overvoltages of resonance. Drive systems with torsionally flexi-

ble couplings can be designed dynamically in accordance with DIN 740 /18/. In this standard, simplified solution proposals for shock-loaded and periodically loaded drives are made, the drive train having been reduced to a two-mass vibration generating system.

3.2 Solution proposal for simple torsional vibrators

Analytic solution for a periodically excited one- (fixed) or two-mass vibration generating system, figure 33.

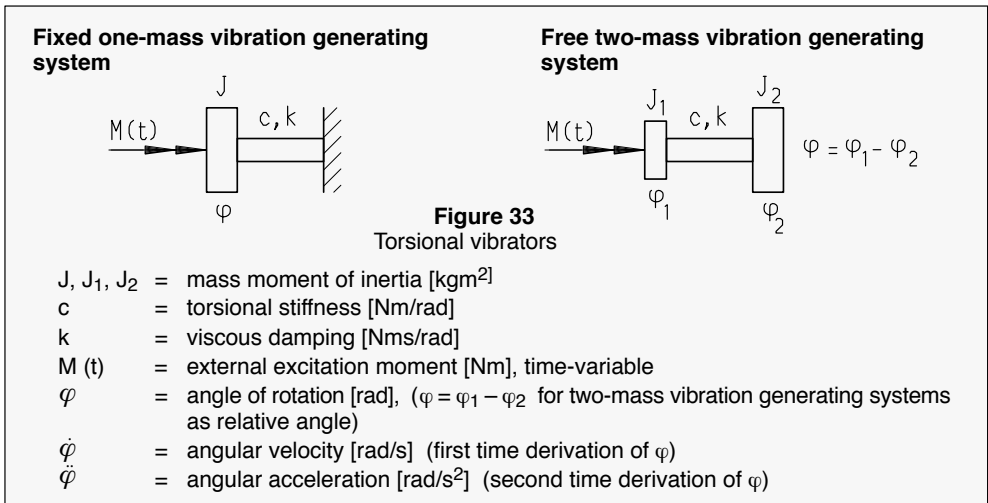

Differential equation of motion:

One-mass vibration generating system:

$$\ddot{\varphi} + \underbrace{\frac{k}{J}}_{2 \delta} \dot{\varphi} + \underbrace{\frac{c}{J}}_{\omega_0^2} \varphi = \frac{M(t)}{J} \quad (32)$$

Two-mass vibration generating system with relative coordinate:

$$\ddot{\varphi} + \underbrace{\frac{k}{J^*}}_{2 \delta} \dot{\varphi} + \underbrace{\frac{c}{J^*}}_{\omega_0^2} \varphi = \frac{M(t)}{J_1} \quad (33)$$

with $\varphi = \varphi_1 - \varphi_2$ (34)

$$J^* = \frac{J_1 \cdot J_2}{J_1 + J_2} \quad (35)$$

Natural radian frequency (undamped): ω_0

$$\omega_0 = \sqrt{\frac{c}{J}} \quad [\text{rad/s}] \quad (36)$$

$$\omega_0 = \sqrt{c \cdot \frac{J_1 + J_2}{J_1 \cdot J_2}} \quad [\text{rad/s}] \quad (37)$$

Natural frequency:

$$f_e = \frac{\omega_0}{2\pi} \quad [\text{Hz}] \quad (38)$$

$$n_e = \frac{\omega_0 \cdot 30}{\pi} \quad [1/\text{min}] \quad (39)$$

$$\delta = \frac{k}{J} = \text{damping constant} \quad [1/\text{s}] \quad (40)$$

ω_0 = natural radian frequency of the undamped vibration [rad/s]

f_e = natural frequency [Hertz]

n_e = natural frequency [1/min]

Vibrations

Solution Proposal for Simple Torsional Vibrators Solution of the Differential Equation of Motion

Damped natural radian frequency:

$$\omega = \sqrt{\omega_0^2 - \delta^2} = \omega_0 \cdot \sqrt{1 - D^2} \quad (41)$$

Attenuation ratio (Lehr's damping): D

$$D = \frac{\delta}{\omega_0} = \frac{k \cdot \omega_0}{2 \cdot c} = \frac{\psi}{4\pi} \quad (42)$$

ψ = damping coefficient on torsionally flexible coupling, determined by a damping hysteresis of a period of oscillation acc. to DIN 740 /18/ and/or acc. to Flender brochure.

$$\psi = \frac{\text{damping energy}}{\text{elastic deformation energy}} = \frac{A_D}{A_e}$$

Reference values for some components:

- D = 0.001...0.01 shafts (material damping of steel)
- D = 0.04...0.08 gear teeth in gear units
- D = 0.04...0.15 (0.2) torsionally flexible couplings
- D = 0.01...0.04 gear couplings, all-steel couplings, universal joint shafts

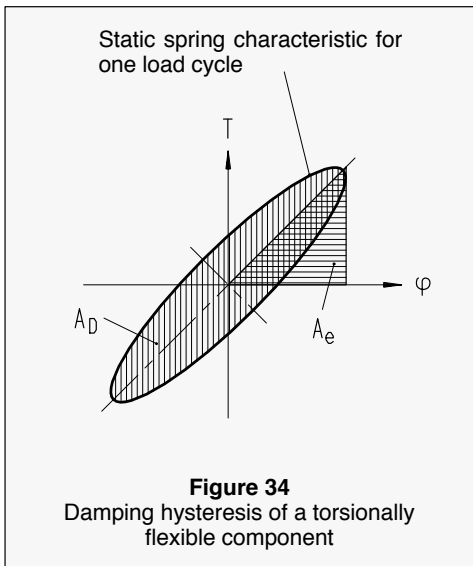

3.3 Solution of the differential equation of motion

Periodic excitation moment

$$M(t) = M_0 \cdot \cos \Omega \cdot t \quad (43)$$

M_0 = amplitude of moment [Nm]

Ω = exciting circuit frequency [rad/s]

Total solution:

$$\varphi = \varphi_h + \varphi_p \quad (44)$$

a) Free vibration (homogeneous solution φ_h)

$$\varphi_h = A \cdot e^{-\delta \cdot t} \cdot \cos(\omega \cdot t - \gamma) \quad (45)$$

Constants A and γ are determined by the starting conditions, e.g. by $\varphi_h = 0$ and $\dot{\varphi}_h = 0$ (initial-value problem).

In damped vibrating systems ($\delta > 0$) the free component of vibration disappears after a transient period.

b) Forced vibration (particular solution φ_p)

$$\varphi_p = \frac{M_0^*}{c} \cdot \frac{1}{\sqrt{(1 - \eta^2)^2 + 4D^2 \cdot \eta^2}} \cdot \cos(\Omega \cdot t - \epsilon) \quad (46)$$

$$\text{Phase angle: } \tan \epsilon = \frac{2 \cdot D \cdot \eta}{1 - \eta^2} \quad (47)$$

$$\text{Frequency ratio: } \eta = \frac{\Omega}{\omega_0} \quad (48)$$

One-mass vibration generating system:

$$M_0^* = M_0 \quad (49)$$

Two-mass vibration generating system:

$$M_0^* = \frac{J_2}{J_1 + J_2} \cdot M_0 \quad (50)$$

c) Magnification factor

$$\varphi_p = \frac{M_0^*}{c} \cdot V \cdot \cos(\Omega \cdot t - \epsilon) \quad (51)$$

$$V = \frac{1}{\sqrt{(1 - \eta^2)^2 + 4D^2 \cdot \eta^2}} = \frac{\hat{\varphi}_p}{\hat{\varphi}_{\text{stat}}} = \frac{M}{M_0^*} \quad (52)$$

Vibrations

Solution of the Differential Equation of Motion Formulae for the Calculation of Vibrations

$\hat{\varphi}_p$ = vibration amplitude of forced vibration
 $\hat{\varphi}_{stat}$ = vibration amplitude of forced vibration at a frequency ratio $\eta = 0$.

The magnification factor shows the ratio of the dynamic and static load and is a measure for the additional load caused by vibrations (figure 35).

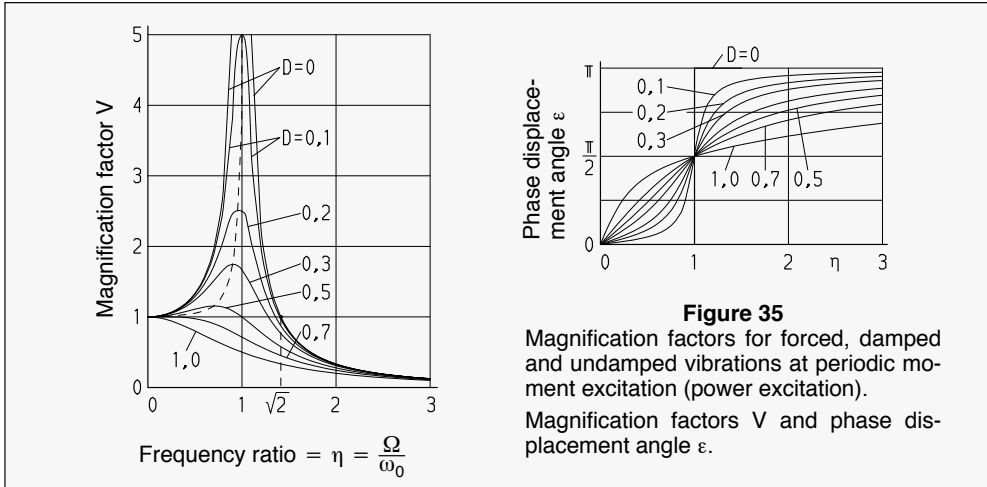

3.4 Formulae for the calculation of vibrations

For the calculation of natural frequencies and vibrational loads, a general vibration generating system has to be converted to a calculable substitute system with point masses, spring and damping elements without mass.

3.4.1 Mass

$m = \rho \cdot V$ [kg]
 V = volume [m³]
 ρ = specific density [kg/m³]

3.4.2 Mass moment of inertia

$J = \int r^2 dm$: general integral formula

	Mass moment of inertia	Torsional stiffness
Cylinder 	$J = \frac{\rho \cdot \pi \cdot L}{32} \cdot D^4$	$c = \frac{\pi \cdot G}{32 L} \cdot D^4$
Hollow cylinder 	$J = \frac{\rho \cdot \pi \cdot L}{32} \cdot (D^4 - d^4)$	$c = \frac{\pi \cdot G}{32 L} \cdot (D^4 - d^4)$
Cone 	$J = \frac{\rho \cdot \pi \cdot L}{160} \cdot \frac{D_1^5 - D_2^5}{D_1 - D_2}$	$c = \frac{3 \cdot \pi \cdot G}{32 L} \cdot \frac{(D_1^3 \cdot D_2^3)}{(D_1^2 + D_1 D_2 + D_2^2)}$
Hollow cone 	$J = \frac{\rho \cdot \pi \cdot L}{160} \cdot \left(\frac{D_1^5 - D_2^5}{D_1 - D_2} - \frac{d_1^5 - d_2^5}{d_1 - d_2} \right)$	$c = \frac{3 \cdot \pi \cdot G}{32 L} \cdot \left[\frac{(D_1^3 \cdot D_2^3)}{(D_1^2 + D_1 D_2 + D_2^2)} - \frac{(d_1^3 \cdot d_2^3)}{(d_1^2 + d_1 d_2 + d_2^2)} \right]$

Vibrations

Terms, Symbols and Units

Table 8 Symbols and units of translational and torsional vibrations			
Term	Quantity	Unit	Explanation
Mass, Mass moment of inertia	m J	kg kg · m ²	Translatory vibrating mass m; Torsionally vibrating mass with mass moment of inertia J
Instantaneous value of vibration (displacement, angle)	x φ	m rad *)	Instantaneous, time-dependent value of vibration amplitude
Amplitude	x _{max} , \hat{x} , A φ _{max} , $\hat{\phi}$, A	m rad	Amplitude is the maximum instantaneous value (peak value) of a vibration.
Oscillating velocity	\dot{x} $\dot{\phi}$	m/s rad/s	Oscillating velocity; Velocity is the instantaneous value of the velocity of change in the direction of vibration.
Inertia force, Moment of inertia forces	m · \ddot{x} J · $\ddot{\phi}$	N N · m	The d'Alembert's inertia force or the moment of inertia force acts in the opposite direction of the positive acceleration.
Spring rate, Torsional spring rate	c' c	Nm N · m/rad	Linear springs
Spring force, Spring moment	c' · x c · φ	N N · m	In case of linear springs, the spring recoil is proportional to deflection.
Attenuation constant (Damping coefficient), Attenuation constant for rotary motion	k' k	N · s/m Nms/rad	In case of Newton's friction, the damping force is proportional to velocity and attenuation constant (linear damping).
Damping factor (Decay coefficient)	$\delta = k' / (2 \cdot m)$ $\delta = k / (2 \cdot J)$	1/s 1/s	The damping factor is the damping coefficient referred to twice the mass.
Attenuation ratio (Lehr's damping)	D = δ/ω ₀	–	For D < 1, a damped vibration exists; for D ≥ 1, an aperiodic case exists.
Damping ratio	$\frac{\hat{x}_n}{\hat{x}_{n+1}}$ $\frac{\hat{\phi}_n}{\hat{\phi}_{n+1}}$	– –	The damping ratio is the relation between two amplitudes, one cycle apart.
Logarithmic damping decrement	$\Lambda = \frac{2 \cdot \pi \cdot D}{\sqrt{1 - D^2}}$	–	$\Lambda = \ln(\hat{x}_n / \hat{x}_{n+1})$ $\Lambda = \ln(\hat{\phi}_n / \hat{\phi}_{n+1})$
Time	t	s	Coordinate of running time
Phase angle	α	rad	In case of a positive value, it is a lead angle.
Phase displacement angle	ε = α ₁ – α ₂	rad	Difference between phase angles of two vibration processes with same radian frequency.
Period of a vibration	T = 2 · π / ω ₀	s	Time during which a single vibration occurs.
Frequency of natural vibration	f = 1/T = ω ₀ / (2 · π)	Hz	Frequency is the reciprocal value to a period of vibrations; vibrations per sec.
Radian frequency of natural vibration	ω ₀ = 2 · π · f	rad/s	Radian frequency is the number of vibrations in 2 · π seconds.
Natural radian frequency (Natural frequency)	ω ₀ = √(c/m) ω ₀ = √(c/J)	rad/s rad/s	Vibration frequency of the natural vibration (undamped) of the system.
Natural radian frequency when damped	ω _d = √(ω ₀ ² – δ ²)	rad/s	For a very small attenuation ratio D < 1 becomes ω _d ≈ ω ₀ .
Excitation frequency	Ω	rad/s	Radian frequency of excitation
Radian frequency ratio	η = Ω/ω ₀	–	Resonance exists at η = 1.

*) The unit "rad" may be replaced with "1".

Vibrations

Formulae for the Calculation of Vibrations

3.4.3 Determination of stiffness

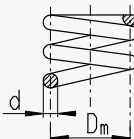
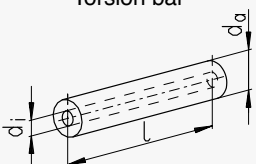
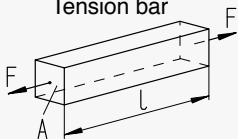
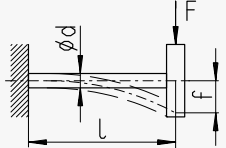
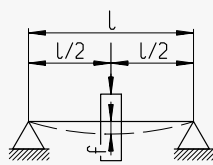
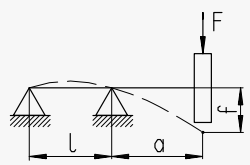
Table 9 Calculation of stiffness (examples)		
Example	Stiffness	Symbols
<p>Coil spring</p> 	$c' = \frac{G \cdot d^4}{8 \cdot D_m^3 \cdot i_F} \left[\frac{\text{N}}{\text{m}} \right]$	<p>i_F = number of windings G = shear modulus ¹⁾ d = diameter of wire D_m = mean coil diameter</p>
<p>Torsion bar</p> 	$c = \frac{G \cdot I_p}{l} \left[\frac{\text{Nm}}{\text{rad}} \right]$ <p>Shaft: $I_p = \frac{\pi \cdot d^4}{32}$</p> <p>Hollow shaft: $I_p = \frac{\pi}{32} (d_a^4 - d_i^4)$</p>	<p>I_p = second polar moment of area l = length d, d_i, d_a = diameters of shafts</p>
<p>Tension bar</p> 	$c' = \frac{E \cdot A}{l} \left[\frac{\text{N}}{\text{m}} \right]$	<p>E = modulus of elasticity ¹⁾ A = cross-sectional area</p>
<p>Cantilever beam</p> 	$c' = \frac{F}{f} = \frac{3 \cdot E \cdot I_a}{l^3} \left[\frac{\text{N}}{\text{m}} \right]$ <p>Shaft: $I_a = \frac{\pi \cdot d^4}{64}$</p> <p>Hollow shaft: $I_a = \frac{\pi}{64} (d_a^4 - d_i^4)$</p>	<p>F = force f = deformation at centre of mass under force F I_a = second axial moment of area</p>
<p>Transverse beam (single load in the middle)</p> 	$c' = \frac{F}{f} = \frac{48 \cdot E \cdot I_a}{l^3} \left[\frac{\text{N}}{\text{m}} \right]$	
<p>Transverse beam with overhanging end</p> 	$c' = \frac{F}{f} = \frac{3 \cdot E \cdot I_a}{a^2 \cdot (l + a)} \left[\frac{\text{N}}{\text{m}} \right]$	<p>l = distance between bearings a = length of overhanging end</p>

1) For steel: $E = 21 \cdot 10^{10} \text{ N/m}^2$; $G = 8.1 \cdot 10^{10} \text{ N/m}^2$

Vibrations

Formulae for the Calculation of Vibrations

Measuring the stiffness:

In a test, stiffness can be determined by measuring the deformation. This is particularly helpful if the geometric structure is very complex and very difficult to acquire.

Translation:

$$c' = \frac{F}{f} \quad [\text{N/m}] \quad (53)$$

F = applied force [N]

f = measured deformation [m]

Torsion:

$$c = \frac{T}{\varphi} \quad [\text{Nm/rad}] \quad (54)$$

T = applied torsion torque [Nm]

φ = measured torsion angle [rad]

Measurements of stiffness are furthermore required if the material properties of the spring material are very complex and it is difficult to rate them exactly. This applies, for instance, to rubber materials of which the resilient properties are dependent on temperature, load frequency, load, and mode of stress (tension, compression, shearing). Examples of application are torsionally flexible couplings and resilient buffers for vibration isolation of machines and internal combustion engines.

These components often have non-linear progressive stiffness characteristics, dependent on the direction of load of the rubber material.

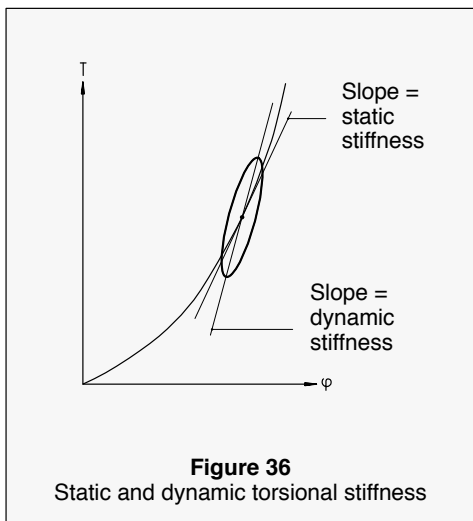

Figure 36

Static and dynamic torsional stiffness

For couplings the dynamic stiffness is given, as a rule, which is measured at a vibrational

frequency of 10 Hz (vibrational amplitude = 25% of the nominal coupling torque). The dynamic torsional stiffness is greater than the static torsional stiffness, see figure 36.

3.4.4 Overlaying of different stiffnesses

To determine resulting stiffnesses, single stiffnesses are to be added where arrangements in series connection or parallel connection are possible.

Series connection:

Rule: The individual springs in a series connection carry the same load, however, they are subjected to different deformations.

$$\frac{1}{c_{\text{ges}}} = \frac{1}{c_1} + \frac{1}{c_2} + \frac{1}{c_3} + \dots + \frac{1}{c_n} \quad (55)$$

Parallel connection:

Rule: The individual springs in a parallel connection are always subject to the same deformation.

$$c_{\text{ges}} = c_1 + c_2 + c_3 + \dots + c_n \quad (56)$$

3.4.5 Conversions

If drives or shafts with different speeds are combined in one vibration generating system, the stiffnesses and masses are to be converted to a reference speed (input or output).

Conversion is carried out as a square of the transmission ratio:

Transmission ratio:

$$i = \frac{n_1}{n_2} = \frac{\text{reference speed}}{\text{speed}} \quad (57)$$

Conversion of stiffnesses c_{n2} and masses J_{n2} with speed n_2 to the respective values c_{n1} and J_{n1} with reference speed n_1 :

$$c_{n1} = c_{n2}/i^2 \quad (58)$$

$$J_{n1} = J_{n2}/i^2 \quad (59)$$

Before combining stiffnesses and masses with different inherent speeds, conversion to the common reference speed has to be carried out first.

3.4.6 Natural frequencies

a) Formulae for the calculation of the natural frequencies of a fixed one-mass vibration generating system and a free two-mass vibration generating system.

Natural frequency f_e in Hertz (1/s):

Vibrations

Formulae for the Calculation of Vibrations Evaluation of Vibrations

One-mass vibration generating system:

$$\text{Torsion: } f_e = \frac{1}{2\pi} \sqrt{\frac{c}{J}} \quad (60)$$

c = torsional stiffness [Nm/rad]
 J, J_i = mass moments of inertia [kgm²]

$$\text{Translation, Bending: } f_e = \frac{1}{2\pi} \sqrt{\frac{c'}{m}} \quad (62)$$

c' = translational stiffness (bending stiffness) [N/m]
 m, m_i = masses [kg]

Two-mass vibration generating system:

$$f_e = \frac{1}{2\pi} \sqrt{c \frac{J_1 + J_2}{J_1 \cdot J_2}} \quad (61)$$

$$f_e = \frac{1}{2\pi} \sqrt{c' \frac{m_1 + m_2}{m_1 \cdot m_2}} \quad (63)$$

b) Natural bending frequencies of shafts supported at both ends with applied masses with known deformation f due to the dead weight.

$$f_e = \frac{q}{2\pi} \sqrt{\frac{g}{f}} \quad [\text{Hz}] \quad (64)$$

g = 9.81 m/s² gravity

f = deformation due to dead weight [m]

q = factor reflecting the effect of the shaft masses on the applied mass

q = 1 shaft mass is neglected compared with the applied mass

q = 1.03 ... 1.09 common values when considering the shaft masses

q = 1.13 solid shaft without pulley

c) Natural bending frequencies for shafts, taking into account dead weights (continuum); general formula for the natural frequency in the order $f_{e,i}$.

$$f_{e,i} = \frac{1}{2\pi} \cdot \left(\frac{\lambda_i}{l}\right)^2 \cdot \sqrt{\frac{IE}{\varrho \cdot A}} \quad [\text{Hz}] \quad (65)$$

λ_i = inherent value factor for the i -th natural frequency

l = length of shaft [m]

E = modulus of elasticity [N/m²]

I = moment of area [m⁴]

ϱ = density [kg/m³]

A = cross-sectional area [m²]

d = diameter of solid shaft [m]

Table 10 λ -values for the first three natural frequencies, dependent on mode of fixing

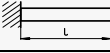
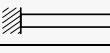
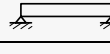
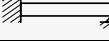
Bearing application	λ_1	λ_2	λ_3
	1.875	4.694	7.855
	4.730	7.853	10.966
	π	2π	3π
	3.927	7.069	10.210

For the solid shaft with free bearing support on both sides, equation (65) is simplified to:

$$f_{e,i} = \frac{\pi \cdot d}{8} \left(\frac{i}{l}\right)^2 \cdot \sqrt{\frac{E}{\varrho}} \quad [\text{Hz}] \quad (66)$$

i = 1st, 2nd, 3rd ... order of natural bending frequencies.

3.5 Evaluation of vibrations

The dynamic load of machines can be determined by means of different measurement methods. Torsional vibration loads in drives, for example, can be measured directly on the shafts by means of wire strain gauges. This requires, however, much time for fixing the strain gauges, for calibration, signal transmission and evaluation. Since torques in shafts are generated via bearing pressure in gear units, belt drives, etc., in case of dynamic loads, structure-borne noise is generated which can be acquired by sensing elements at the bearing points in different directions (axial, horizontal, vertical). Dependent on the requirements, the amplitudes of vibration displacement, velocity and acceleration can be recorded and evaluated in a sum (effective vibration

Vibrations

Formulae for the Calculation of Vibrations

velocity) or frequency-selective. The structure-borne noise signal reflects besides the torque load in the shafts also unbalances, alignment errors, meshing impulses, bearing noises, and possibly developing machine damages.

To evaluate the actual state of a machine, VDI guideline 2056¹⁾ or DIN ISO 10816-1 /19, 20/ is consulted for the effective vibration velocity, as a rule, taking into account structure-borne noise in the frequency range between 10 and 1,000 Hertz. Dependent on the machine support structure (resilient or rigid foundation) and power transmitted, a distinction is made between four machine groups (table 11). Dependent on the vibration velocity, the vibrational state of a machine is judged to be "good", "acceptable", "still permissible", and "non-permis-

sible". If vibration velocities are in the "non-permissible" range, measures to improve the vibrational state of the machine (balancing, improving the alignment, replacing defective machine parts, displacing the resonance) are required, as a rule, or it has to be verified in detail that the vibrational state does not impair the service life of the machine (experience, verification by calculation).

Structure-borne noise is emitted from the machine surface in the form of airborne noise and has an impact on the environment by the generated noises. For the evaluation of noise, sound pressure level and sound intensity are measured. Gear unit noises are evaluated according to VDI guideline 2159 or DIN 45635 /17, 16/, see subsection 1.5.

Table 11 Boundary limits acc. to VDI guideline 2056¹⁾ for four machine groups

Machine groups	Including gear units and machines with input power ratings of ...	Range classification acc. to VDI 2056 ("Effective value of the vibration velocity" in mm/s)			
		Good	Acceptable	Still permissible	Non-permissible
K	... up to approx. 15 kW without special foundation.	up to 0.7	0.7 ... 1,8	1.8 ... 4.5	from 4.5 up
M	... from approx. 15 up to 75 kW without special foundation. ... from approx. 75 up to 300 kW and installation on highly tuned, rigid or heavy foundations.	up to 1.1	1.1 ... 2.8	2.8 ... 7.1	from 7.1 up
G	... over 300 kW and installation on highly tuned, rigid or heavy foundations.	up to 1.8	1.8 ... 4.5	4.5 ... 11	from 11 up
T	... over 75 kW and installation on broadly tuned resilient foundations (especially also steel foundations designed according to light-construction guidelines).	up to 2.8	2.8 ... 7	7 ... 18	from 18 up

1) 08/97 withdrawn without replacement; see /20/

Table of Contents Section 13

	Page
Bibliography of Sections 10, 11, and 12	138 + 139

Bibliography

- /1/ DIN 3960: Definitions, parameters and equations for involute cylindrical gears and gear pairs. March 1987 edition. Beuth Verlag GmbH, Berlin

- /2/ DIN 3992: Addendum modification of external spur and helical gears. March 1964 edition. Beuth Verlag GmbH, Berlin

- /3/ DIN 3993: Geometrical design of cylindrical internal involute gear pairs; Part 3. August 1981 edition. Beuth Verlag GmbH, Berlin

- /4/ DIN 3994: Addendum modification of spur gears in the 05-system. August 1963 edition. Beuth Verlag GmbH, Berlin

- /5/ Niemann, G. und Winter, H.: Maschinenelemente, Band II, Getriebe allgemein, Zahnradgetriebe-Grundlagen, Stirnradgetriebe. 3rd edition. Springer Verlag, Heidelberg, New York, Tokyo (1985)

- /6/ Sigg, H.: Profile and longitudinal corrections on involute gears. Semi-Annual Meeting of the AGMA 1965, Paper 109.16

- /7/ Hösel, Th.: Ermittlung von Tragbild und Flankenrichtungskorrekturen für Evolventen-Stirnräder, Berechnungen mit dem FVA-Programm "Ritzelkorrektur", Zeitschrift Antriebstechnik 22, (1983) Nr. 12

- /8/ DIN 3990: Calculation of load capacity of cylindrical gears.
Part 1: Introduction and general influence factors
Part 2: Calculation of pitting resistance
Part 3: Calculation of tooth strength
Part 4: Calculation of scuffing load capacity
Beuth Verlag GmbH, Berlin, December 1987

- /9/ FVA-Stirnradprogramm: Vergleich und Zusammenfassung von Zahnradberechnungen mit Hilfe von EDV-Anlagen (jeweils neuester Programmstand), FVA-Forschungsvorhaben Nr. 1, Forschungsvereinigung Antriebstechnik, Frankfurt am Main

- /10/ DIN 3990: Calculation of load capacity of cylindrical gears. Application standard for industrial gears.
Part 11: Detailed method; February 1989 edition
Part 12: Simplified method; Draft May 1987
Beuth Verlag GmbH, Berlin

- /11/ DIN 3990: Calculation of load capacity of cylindrical gears.
Part 5: Endurance limits and material qualities; December 1987
Beuth Verlag GmbH, Berlin

Bibliography

- /12/ FVA-Arbeitsblatt zum Forschungsvorhaben Nr. 8: Grundlagenversuche zur Ermittlung der richtigen Härtetiefe bei Wälz- und Biegebeanspruchung. Stand Dezember 1976, Forschungsvereinigung Antriebstechnik, Frankfurt am Main

- /13/ FVA-Ritzelkorrekturprogramm: EDV-Programm zur Ermittlung der Zahnflankenkorrekturen zum Ausgleich der lastbedingten Zahnverformungen (jeweils neuester Programmstand), FVA-Forschungsvorhaben Nr. 30, Forschungsvereinigung Antriebstechnik, Frankfurt am Main

- /14/ Niemann, G.: Maschinenelemente 2. Bd., Springer-Verlag Berlin, Heidelberg, New York, 1965

- /15/ Theissen, J.: Vergleichskriterien für Grossgetriebe mit Leistungsverzweigung, VDI-Bericht 488 "Zahnradgetriebe 1983 - mehr Know how für morgen", VDI-Verlag, 1983

- /16/ DIN 45635: Measurement of noise emitted by machines.
Part 1: Airborne noise emission; Enveloping surface method; Basic method, divided into 3 grades of accuracy; April 1984 edition
Part 23: Measurement of airborne noise; Enveloping surface method; Gear transmission; July 1978 edition
Beuth Verlag GmbH, Berlin

- /17/ VDI-Richtlinien 2159: Emissionskennwerte technischer Schallquellen; Getriebegeräusche; Verein Deutscher Ingenieure, July 1985

- /18/ DIN 740: Flexible shaft couplings. Part 2. Parameters and design principles. August 1986 edition; Beuth Verlag GmbH, Berlin

- /19/ VDI-Richtlinien 2056: Beurteilungsmaßstäbe für mechanische Schwingungen von Maschinen. VDI-Handbuch Schwingungstechnik; Verein Deutscher Ingenieure; October 1964; (08.97 withdrawn without replacement)

- /20/ DIN ISO 10816-1: Mechanical vibration - Evaluation of machine vibration by measurements on non-rotating parts. August 1997 edition; Beuth Verlag GmbH, Berlin

TRANSLATION
of
Technical Handbook
5th Edition 03/2009
Copyright by FLENDER AG Bocholt

The information provided in this brochure contains merely general descriptions or characteristics of performance which in actual case of use do not always apply as described or which may change as a result of further development of the products. An obligation to provide the respective characteristics shall only exist if expressly agreed in the terms of contract.

All product designations may be trademarks or product names of Siemens AG or supplier companies whose use by third parties for their own purposes could violate the rights of the owners.

A. Friedrich Flender AG
P.O. Box 1364
46393 BOCHOLT
GERMANY

Subject to change without prior notice
Order No.: E86060-T5701-A101-A1-7600
Dispo 18500
BU 0309 3.0 Ro 148 En
Printed in Germany
© Siemens AG 2009

www.siemens.com/drivetechnology

Token fee: 3.00 €